



Hewlett Packard
Enterprise

HPE ProLiant DL60 Gen9 Server

User Guide

Abstract

This document is for the person who installs, administers, and troubleshoots servers and storage systems. Hewlett Packard Enterprise assumes you are qualified in the servicing of computer equipment and trained in recognizing hazards in products with hazardous energy levels.

Part Number: 786245-003
April 2016
Edition: 3

© Copyright 2014, 2016 Hewlett Packard Enterprise Development LP

The information contained herein is subject to change without notice. The only warranties for Hewlett Packard Enterprise products and services are set forth in the express warranty statements accompanying such products and services. Nothing herein should be construed as constituting an additional warranty. Hewlett Packard Enterprise shall not be liable for technical or editorial errors or omissions contained herein.

Linux® is the registered trademark of Linus Torvalds in the U.S. and other countries.

Microsoft® and Windows® are either registered trademarks or trademarks of Microsoft Corporation in the United States and/or other countries.

microSD® is a trademark or a registered trademark of SD-3C in the United States, other countries or both.

Intel® and Xeon® are registered trademarks of Intel Corporation in the U.S. and other countries.

Contents

| | |
|--|----|
| Component identification | 6 |
| Front panel components..... | 6 |
| Front panel LEDs and buttons | 7 |
| Front panel LED power fault codes..... | 8 |
| Rear panel components | 8 |
| Rear panel LEDs..... | 9 |
| PCIe riser board slot definitions | 9 |
| System board components | 10 |
| DIMM slot locations | 11 |
| System maintenance switch..... | 11 |
| NMI functionality | 12 |
| Drive numbering | 12 |
| Hot-plug drive LED definitions..... | 13 |
| Fan locations | 14 |
| Operations..... | 15 |
| Power up the server | 15 |
| Power down the server..... | 15 |
| Extend the server from the rack..... | 15 |
| Access the product rear panel | 17 |
| Opening the cable management arm..... | 17 |
| Remove the server from the rack..... | 18 |
| Remove the security bezel (optional)..... | 18 |
| Remove the access panel..... | 18 |
| Install the access panel | 19 |
| Remove the air baffle | 19 |
| Install the air baffle | 20 |
| Remove the PCI riser cage | 21 |
| Install the PCI riser cage | 23 |
| Setup..... | 26 |
| Optional services..... | 26 |
| Optimum environment..... | 26 |
| Space and airflow requirements..... | 26 |
| Temperature requirements..... | 27 |
| Power requirements | 27 |
| Electrical grounding requirements | 28 |
| Server warnings and cautions..... | 28 |
| Rack warnings | 29 |
| Identifying the contents of the server shipping carton | 29 |
| Installing hardware options | 30 |
| Installing the server into the rack | 30 |
| Installing the rack rail hook-and-loop strap | 33 |
| Installing the operating system..... | 34 |
| Powering on and selecting boot options in UEFI Boot Mode | 35 |
| Registering the server | 35 |
| Hardware options installation | 36 |
| Introduction..... | 36 |
| Security bezel option | 36 |
| Drive options..... | 36 |
| Drive installation guidelines..... | 37 |
| Installing a non-hot-plug drive | 37 |
| Installing a hot-plug drive | 38 |
| Storage controller options | 39 |

| | |
|--|-----------|
| Installing a storage controller and FBWC module | 40 |
| Installing a Smart Storage Battery | 42 |
| Drive cable options | 43 |
| Mini-SAS cable options | 43 |
| Optical drive option | 45 |
| Redundant fan option | 46 |
| Fan population guidelines | 47 |
| Installing a hot-swap fan module | 47 |
| Memory options | 49 |
| Memory-processor compatibility information | 49 |
| SmartMemory | 50 |
| Memory subsystem architecture | 51 |
| Single-, dual-, and quad-rank DIMMs | 51 |
| DIMM identification | 52 |
| Memory configurations | 52 |
| General DIMM slot population guidelines | 53 |
| Identifying the processor type | 54 |
| Installing a DIMM | 54 |
| Processor option | 55 |
| Processor installation cautions | 56 |
| Installing a processor | 56 |
| FlexibleLOM option | 61 |
| Full-height half-length riser option | 63 |
| Expansion board options | 65 |
| M.2 SSD enablement option | 68 |
| Dual 8Gb microSD Enterprise Midline USB device | 70 |
| Redundant power supply option | 71 |
| Power input module and RPS backplane characteristics | 71 |
| Installing the redundant power supply option | 71 |
| HP Trusted Platform Module option | 76 |
| Installing the Trusted Platform Module board | 76 |
| Retaining the recovery key/password | 78 |
| Enabling the Trusted Platform Module | 78 |
| Cabling | 80 |
| Cabling overview | 80 |
| Storage cabling | 80 |
| Four-bay LFF non-hot-plug drive cabling | 80 |
| Four-bay LFF hot-plug drive cabling | 81 |
| M.2 SSD cabling | 83 |
| FBWC cabling | 85 |
| Smart Storage battery cabling | 87 |
| Power supply cabling | 88 |
| Optical drive cabling | 89 |
| Front I/O cabling | 89 |
| Software and configuration utilities | 90 |
| Server mode | 90 |
| Product QuickSpecs | 90 |
| HPE iLO | 90 |
| Active Health System | 91 |
| RESTful API support for iLO | 92 |
| Integrated Management Log | 92 |
| Intelligent Provisioning | 92 |
| HPE Insight Diagnostics | 93 |
| HPE Insight Diagnostics survey functionality | 93 |
| Erase Utility | 93 |
| Scripting Toolkit for Windows and Linux | 94 |
| Service Pack for ProLiant | 94 |
| HP Smart Update Manager | 94 |
| HPE UEFI System Utilities | 94 |
| Using UEFI System Utilities | 95 |

| | |
|--|-----|
| Flexible boot control | 95 |
| Restoring and customizing configuration settings | 96 |
| Secure Boot configuration | 96 |
| Embedded UEFI shell | 96 |
| Embedded Diagnostics option | 97 |
| RESTful API support for UEFI | 97 |
| Re-entering the server serial number and product ID | 97 |
| Utilities and features | 97 |
| HPE Smart Storage Administrator | 97 |
| Automatic Server Recovery | 98 |
| USB support | 98 |
| Redundant ROM support | 98 |
| Keeping the system current | 99 |
| Access to Hewlett Packard Enterprise Support Materials | 99 |
| Updating firmware or System ROM | 99 |
| Drivers | 101 |
| Software and firmware | 101 |
| Operating System Version Support | 101 |
| Version control | 101 |
| Operating systems and virtualization software support for ProLiant servers | 102 |
| HPE Technology Service Portfolio | 102 |
| Change control and proactive notification | 102 |
| Troubleshooting | 103 |
| Troubleshooting resources | 103 |
| System battery replacement | 104 |
| Warranty and regulatory information | 106 |
| Warranty information | 106 |
| Regulatory information | 106 |
| Safety and regulatory compliance | 106 |
| Belarus Kazakhstan Russia marking | 106 |
| Turkey RoHS material content declaration | 107 |
| Ukraine RoHS material content declaration | 107 |
| Electrostatic discharge | 108 |
| Preventing electrostatic discharge | 108 |
| Grounding methods to prevent electrostatic discharge | 108 |
| Specifications | 109 |
| Environmental specifications | 109 |
| Mechanical specifications | 109 |
| Power supply specifications | 109 |
| Hot-plug power supply calculations | 110 |
| Support and other resources | 111 |
| Accessing Hewlett Packard Enterprise Support | 111 |
| Information to collect | 111 |
| Accessing updates | 111 |
| Websites | 111 |
| Customer Self Repair | 112 |
| Remote support | 119 |
| Acronyms and abbreviations | 120 |
| Documentation feedback | 124 |
| Index | 125 |

Component identification

Front panel components

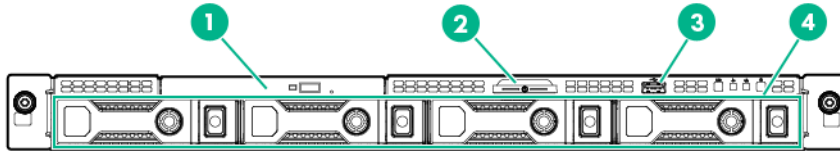

| Item | Description |
|------|---|
| 1 | Optical drive (optional) |
| 2 | Serial label pull tab The serial number/iLO information pull tab is double-sided. The top side shows the server serial number and the customer asset tag label. The reverse side shows the default iLO account information and QR code label. Use your mobile device to scan the QR code label to display the server mobile product page (http://www.hpe.com/qref/dl60gen9). This page contains links to server setup information, spare part numbers, QuickSpecs, troubleshooting resources, and other useful product links. |
| 3 | USB 2.0 connector |
| 4 | LFF drives |

Front panel LEDs and buttons

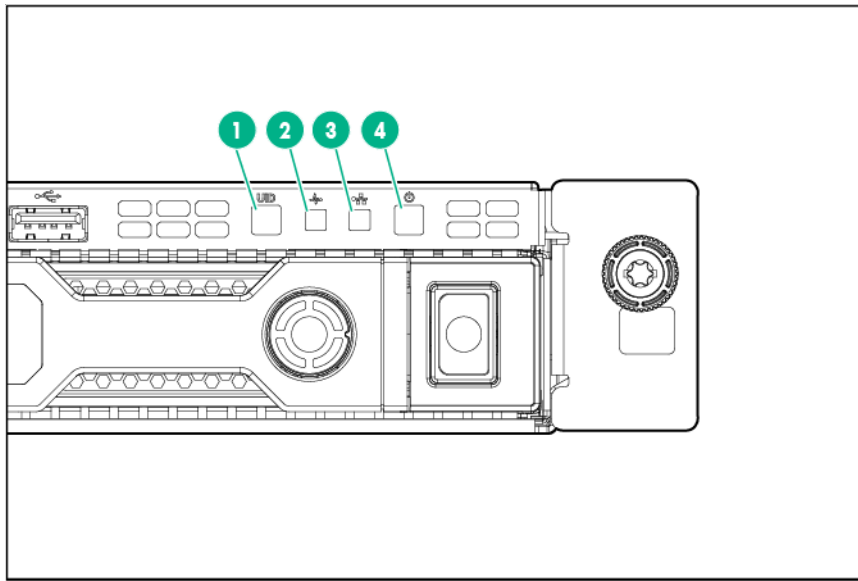

| Item | Description | Status |
|------|--|---|
| 1 | UID button/LED | <p>Solid blue = Activated Flashing blue:</p> <ul style="list-style-type: none"> • 1 flash per second = Remote management or firmware upgrade in progress • 4 flashes per second = iLO manual reboot sequence initiated • 8 flashes per second = iLO manual reboot sequence in progress <p>Off = Deactivated</p> |
| 2 | Health LED | <p>Solid green = Normal Flashing green (1 flash per second) = iLO is rebooting Flashing amber = System degraded Flashing red (1 flash per second) = System critical</p> <p>If the health LED indicates a degraded or critical state, review the system IML ("Integrated Management Log" on page 92) or use iLO ("HPE iLO" on page 90) to review the system health status.</p> |
| 3 | NIC status LED | <p>Solid green = Link to network Flashing green (1 flash per second) = Network active Off = No network activity</p> |
| 4 | Power On/Standby button and system power LED | <p>Solid green = System on Flashing green (1 flash per second) = Performing power on sequence Solid amber = System in standby Off = No power present</p> <p>If the system power LED is off, verify the following conditions:</p> <ul style="list-style-type: none"> • Facility power is present. • The power supply is installed and is working correctly. • The power cord is attached and is connected to a power source. • The front I/O cable is connected. |

When all four LEDs described in this table flash simultaneously, a power fault has occurred. For more information, see "Power fault LEDs ("Front panel LED power fault codes" on page 8)."

Front panel LED power fault codes

The following table provides a list of power fault codes, and the subsystems that are affected. Not all power faults are used by all servers.

| Subsystem | Front panel LED behavior |
|--|--------------------------|
| System board | 1 flash |
| Processor | 2 flashes |
| Memory | 3 flashes |
| Riser board PCIe slots | 4 flashes |
| FlexibleLOM | 5 flashes |
| Removable HPE Flexible Smart Array controller/Smart SAS HBA controller | 6 flashes |
| System board PCIe slots | 7 flashes |
| Power backplane or storage backplane | 8 flashes |
| Power supply | 9 flashes |

For more information, see "Front panel LEDs and buttons (on page 7)."

Rear panel components

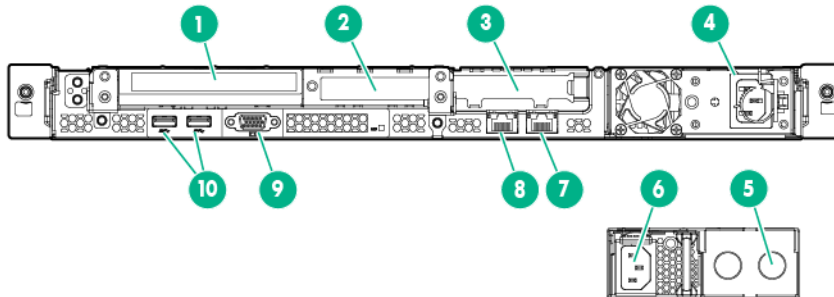

| Item | Description |
|------|---|
| 1 | Slot 3 PCIe3 x8 (8, 4, 1) |
| 2 | Slot 2 PCIe3 x8 (8, 4, 1) |
| 3 | Slot 1 PCIe3 x16 (16, 8, 4, 1) |
| 4 | Non-hot-plug power supply |
| 5 | Power supply blank (bay 2 of optional redundant power supply module) |
| 6 | Hot-plug power supply (bay 1 of optional redundant power supply module) |
| 7 | NIC connector 2 |
| 8 | NIC connector 1/iLO connector |
| 9 | Video connector |
| 10 | USB 3.0 connectors |

Rear panel LEDs

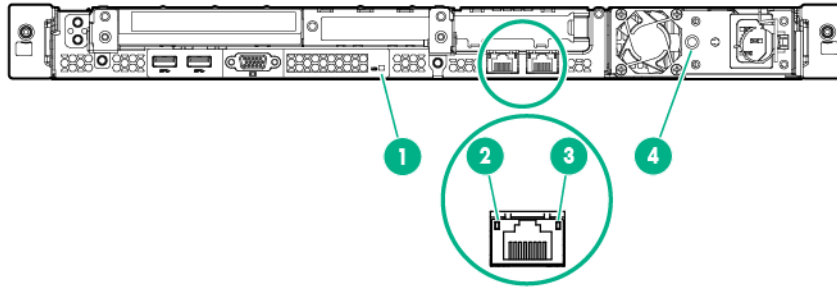

| Item | Description | Status |
|------|------------------|---|
| 1 | UID LED | Solid blue = Activated Flashing blue: <ul style="list-style-type: none"> • 1 flash per second = Remote management or firmware upgrade in progress • 4 flashes per second = iLO manual reboot sequence initiated • 8 flashes per second = iLO manual reboot sequence in progress Off = Deactivated |
| 2 | NIC link LED | Green = Network link Off = No network link |
| 3 | NIC activity LED | Solid green = Link to network Flashing green = Network active Off = No network activity |
| 4 | Power supply LED | Solid green = Normal Off = One or more of the following conditions exists: <ul style="list-style-type: none"> • Power is unavailable • Power supply failed • Power supply is in standby mode • Power supply error |

PCIe riser board slot definitions

| Expansion Slots | Riser board options | Technology | Bus Width | Connector Width | Form Factor |
|-----------------|------------------------|------------|-----------|-----------------|-------------------------------------|
| 1 | PCIe riser | PCIe 3.0 | x16 | x16 | Low-profile |
| 2 | PCIe riser | PCIe 3.0 | x8 | x8 | Low-profile |
| 3 | PCIe riser FlexibleLOM | PCIe 3.0 | x8 x8 | x8 x8 | Full-height/Half-length FlexibleLOM |

System board components

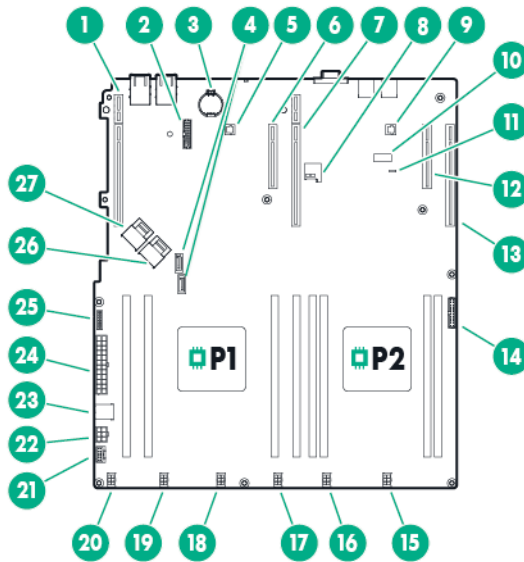

| Item | Description |
|------|---|
| 1 | Primary PCIe riser board connector* |
| 2 | TPM connector |
| 3 | System battery |
| 4 | SATA connector |
| 5 | Storage backup power connector for PCIe slots 1-2 |
| 6 | Reserved |
| 7 | Secondary PCIe riser board connector* |
| 8 | MicroSD slot |
| 9 | Storage backup power connector for PCIe slot 3 |
| 10 | System maintenance switch |
| 11 | NMI header |
| 12 | Reserved |
| 13 | Reserved |
| 14 | Front I/O connector |
| 15 | Fan 6 connector |
| 16 | Fan 5 connector |
| 17 | Fan 4 connector |
| 18 | Fan 3 connector |
| 19 | Fan 2 connector |
| 20 | Fan 1 connector |
| 21 | Smart Storage Battery connector |
| 22 | 6-pin drive backplane power connector |
| 23 | Internal USB 3.0 connector |
| 24 | 24-pin power connector |
| 25 | 16-pin PS connector |
| 26 | Mini-SAS connector 1 |
| 27 | Mini-SAS connector 2 |

* For more information on the riser board slots supported by the onboard PCI riser connectors, see "PCIe riser board slot definitions (on page 9)."

DIMM slot locations

DIMM slots are numbered sequentially (1 through 4) for each processor. The supported AMP modes use the letter assignments for population guidelines.

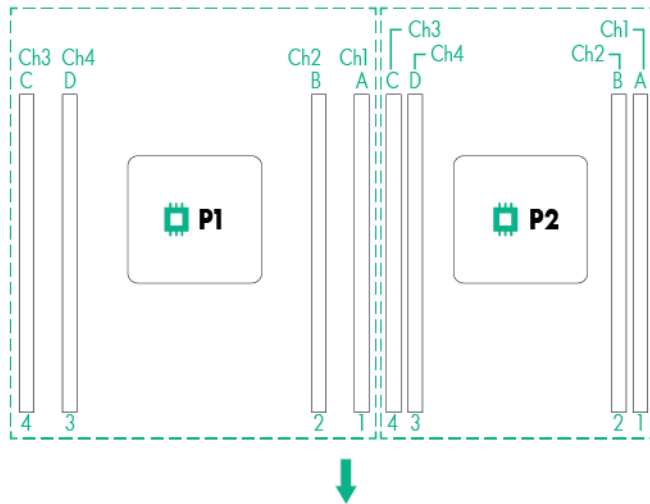

The arrow points to the front of the server.

System maintenance switch

| Position | Default | Function |
|----------|---------|--|
| S1 | Off | Off = iLO 4 security is enabled. On = iLO 4 security is disabled. |
| S2 | Off | Off = System configuration can be changed. On = System configuration is locked. |
| S3 | Off | Reserved |
| S4 | Off | Reserved |
| S5 | Off | Off = Power-on password is enabled. On = Power-on password is disabled. |
| S6 | Off | Off = No function On = ROM reads system configuration as invalid. |
| S7 | Off | Off = Set default boot mode to UEFI. On = Set default boot mode to legacy. |
| S8 | — | Reserved |
| S9 | — | Reserved |
| S10 | — | Reserved |
| S11 | — | Reserved |
| S12 | — | Reserved |

To access the redundant ROM, set S1, S5, and S6 to On.

When the system maintenance S6 switch is set to the On position, the system will erase all system configuration settings from both CMOS and NVRAM on the next reboot.



CAUTION: Clearing CMOS and/or NVRAM deletes configuration information. Be sure to properly configure the server or data loss could occur.

Before using the S7 switch to change the boot mode to Legacy BIOS Mode, you must first disable the Dynamic Smart Array B140i Controller.

To disable the Dynamic Smart Array B140i Controller:

1. Reboot the server.
The server restarts and the POST screen appears.
2. Press **F9**.
The System Utilities screen appears.
3. Select **System Configuration** → **BIOS/Platform Configuration (RBSU)** → **System Options** → **SATA Controller Options** → **Embedded SATA Configuration**, and then press **Enter**.
4. Select **Enable SATA AHCI Support**, and then press **Enter**.
5. Press **F10** to save the selection.
6. Press **Y** to save the changes.
The `Change saved confirmation` prompt appears.
7. Select **Exit and resume system boot**, and press **Enter**.

The server continues the normal boot process.

NMI functionality

An NMI crash dump creates a crash dump log before resetting a system which is not responding.

Crash dump log analysis is an essential part of diagnosing reliability problems, such as failures of operating systems, device drivers, and applications. Many crashes freeze a system, and the only available action for administrators is to restart the system. Resetting the system erases any information which could support problem analysis, but the NMI feature preserves that information by performing a memory dump before a system reset.

To force the system to invoke the NMI handler and generate a crash dump log, do one of the following:

- Use the iLO Virtual NMI feature.
- Short the NMI header ("[System board components](#)" on page 10).

For more information, see the Hewlett Packard Enterprise website (<http://www.hpe.com/support/NMI-CrashDump>).

Drive numbering



Hot-plug drive LED definitions

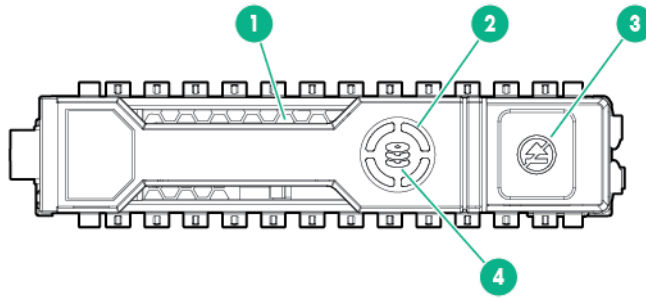

| Item | LED | Status | Definition |
|------|---------------|---|--|
| 1 | Locate | Solid blue | The drive is being identified by a host application. |
| | | Flashing blue | The drive carrier firmware is being updated or requires an update. |
| 2 | Activity ring | Rotating green | Drive activity |
| | | Off | No drive activity |
| 3 | Do not remove | Solid white | Do not remove the drive. Removing the drive causes one or more of the logical drives to fail. |
| | | Off | Removing the drive does not cause a logical drive to fail. |
| 4 | Drive status | Solid green | The drive is a member of one or more logical drives. |
| | | Flashing green | The drive is rebuilding or performing a RAID migration, strip size migration, capacity expansion, or logical drive extension, or is erasing. |
| | | Flashing amber/green | The drive is a member of one or more logical drives and predicts the drive will fail. |
| | | Flashing amber | The drive is not configured and predicts the drive will fail. |
| | | Solid amber | The drive has failed. |
| | Off | The drive is not configured by a RAID controller. | |

The blue Locate LED is behind the release lever and is visible when illuminated.



IMPORTANT: The Dynamic Smart Array B140i Controller is only available in UEFI Boot Mode. It cannot be enabled in Legacy BIOS Boot Mode. If the B140i controller is disabled, drives connected to the system board Mini-SAS connectors operate in AHCI or Legacy mode. Under this condition:

- The drives cannot be a part of a hardware RAID or a logical drive.
- The Locate, Drive status, and Do not remove LEDs of the affected drives are disabled.

Use BIOS/Platform Configuration (RBSU) in the UEFI System Utilities ("[HPE UEFI System Utilities](#)" on page 94) to enable or disable the B140i controller (System Configuration → BIOS/Platform Configuration (RBSU) → System Options → SATA Controller Options → Embedded SATA Configuration).

Fan locations

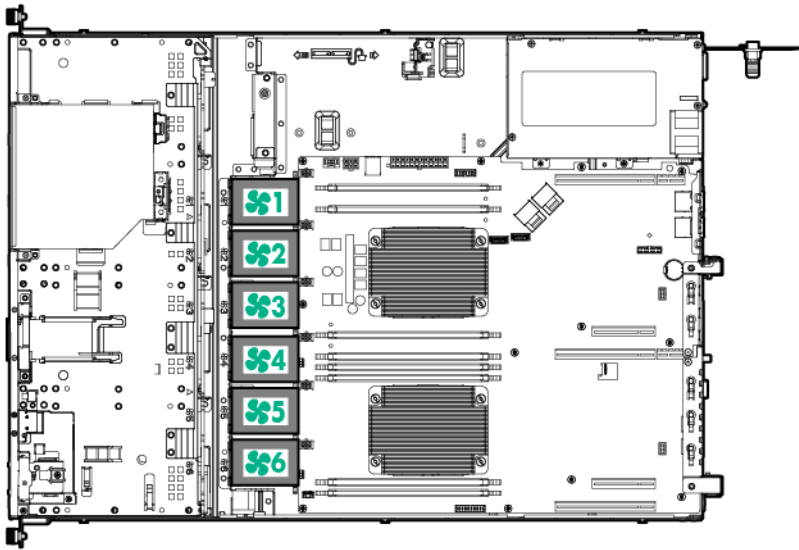

Operations

Power up the server

1. Connect each power cord to the server.
2. Connect each power cord to the power source.
3. Press the Power On/Standby button.

The server exits standby mode and applies full power to the system. The system power LED changes from amber to green.

Power down the server

Before powering down the server for any upgrade or maintenance procedures, perform a backup of critical server data and programs.



WARNING: To reduce the risk of personal injury, electric shock, or damage to the equipment, disconnect the power cord to remove power from the server. The front panel Power On/Standby button does not completely shut off system power. Portions of the power supply and some internal circuitry remain active until the power cord is disconnected.



IMPORTANT: When the server is in standby mode, auxiliary power is still being provided to the system.

To power down the server, use one of the following methods:

- Press and release the Power On/Standby button.
This method initiates a controlled shutdown of applications and the OS before the server enters standby mode.
- Press and hold the Power On/Standby button for more than 4 seconds to force the server to enter standby mode.
This method forces the server to enter standby mode without properly exiting applications and the OS. If an application stops responding, you can use this method to force a shutdown.
- Use a virtual power button selection through iLO 4.
This method initiates a controlled remote shutdown of applications and the OS before the server enters standby mode.

Before proceeding, verify the server is in standby mode by observing that the system power LED is amber.

Extend the server from the rack

To extend the server from a Hewlett Packard Enterprise, Compaq-branded, Telco, or third-party rack:



WARNING: To reduce the risk of personal injury or equipment damage, be sure that the rack is adequately stabilized before extending a component from the rack.



WARNING: To reduce the risk of personal injury, be careful when pressing the server rail-release latches and sliding the server into the rack. The sliding rails could pinch your fingers.

1. If the rear panel cables are not secured by a cable management arm, do the following:
 - a. Power down the server (on page 15).
 - b. Disconnect all peripheral cables from the server.
 - c. Disconnect each power cord from the server.
2. Do one of the following:
 - o In a server that uses thumbscrew rack ears, loosen the captive thumbscrews that secure the server faceplate to the front of the rack, and then slide the server out of the rack.

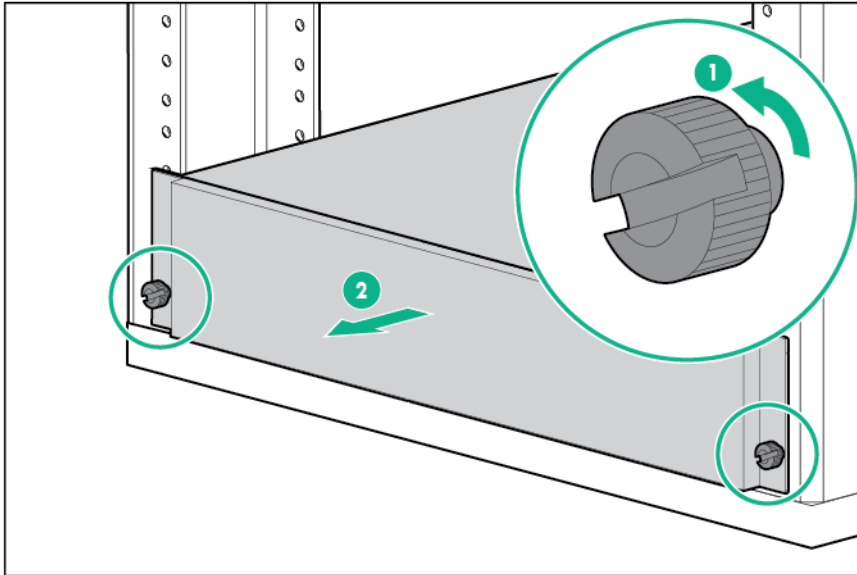

- o In a server that uses quick-release latch rack ears:
 - i. Open the latches on both sides of the server.
 - ii. If necessary, use a T-25 Torx screwdriver to loosen the shipping screws.
 - iii. Slide the server out of the rack.

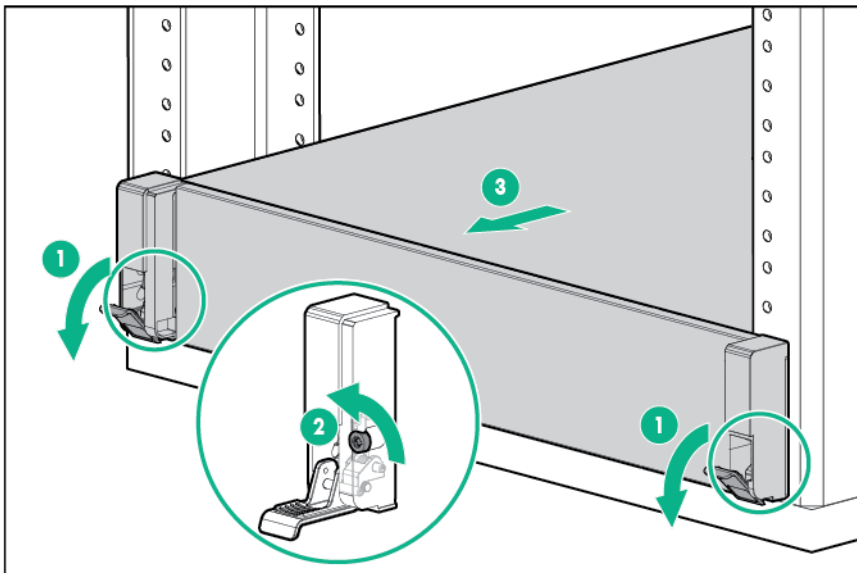

3. After performing the installation or maintenance procedure, slide the server back into the rack, and then press the server firmly into the rack to secure it in place.
4. Do one of the following:
 - o In a server that uses thumbscrew rack ears, tighten the captive thumbscrews.

- o In a server that uses quick-release latch rack ears, if necessary, tighten the shipping screws.
5. If the rear panel cables were disconnected because a cable management arm is not in use, do the following:
 - a. Connect each power cord to the server.
 - b. Connect all peripheral cables to the server.
 - c. Power up the server (on page 15).

Access the product rear panel

Opening the cable management arm

To access the server rear panel:

1. Release the cable management arm.

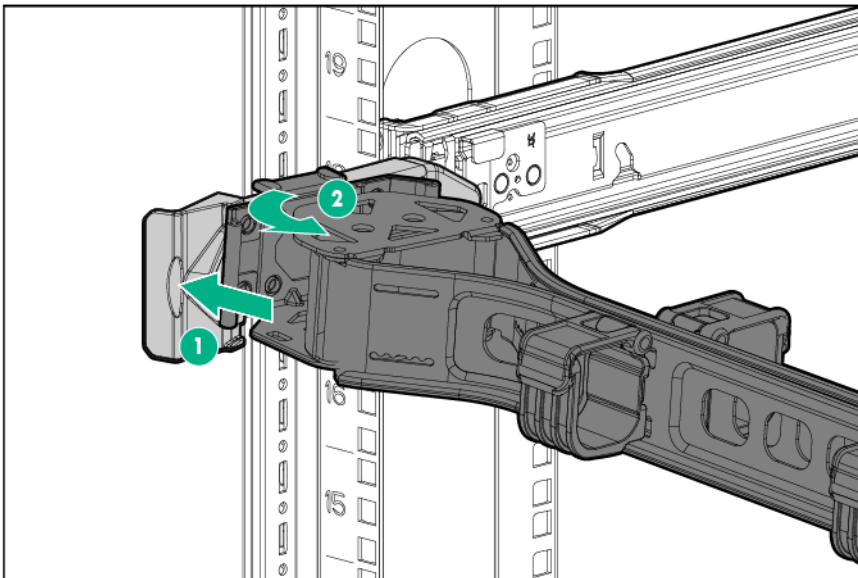

2. Open the cable management arm. The cable management arm can be right-mounted or left-mounted.

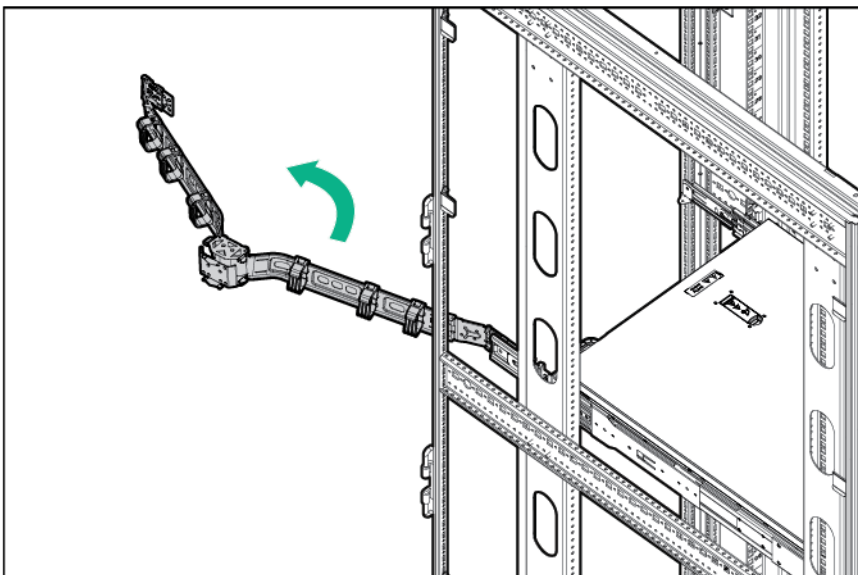

Remove the server from the rack

- ⚠ WARNING:** This server is very heavy. To reduce the risk of personal injury or damage to the equipment:
- Observe local occupational health and safety requirements and guidelines for manual material handling.
 - Get help to lift and stabilize the product during installation or removal, especially when the product is not fastened to the rails. Hewlett Packard Enterprise recommends that a minimum of two people are required for all rack server installations. A third person may be required to help align the server if the server is installed higher than chest level.
 - Use caution when installing the server in or removing the server from the rack; it is unstable when not fastened to the rails.

To remove the server from a Hewlett Packard Enterprise, Compaq-branded, Telco, or a third-party rack:

1. Power down the server (on page 15).
2. Disconnect all peripheral cables from the server.
3. Disconnect each power cord from the server.
4. Extend the server on the rack rails until the server rail-release latches engage.
5. Remove the server from the rack.

For instructions on how to extend or remove the server from the rack, see the documentation that ships with the rack rail system.

6. Place the server on a sturdy, level surface.

Remove the security bezel (optional)

The security bezel is only supported in servers using the quick-release latch rack ears.

To access the front panel components, unlock and then remove the security bezel.

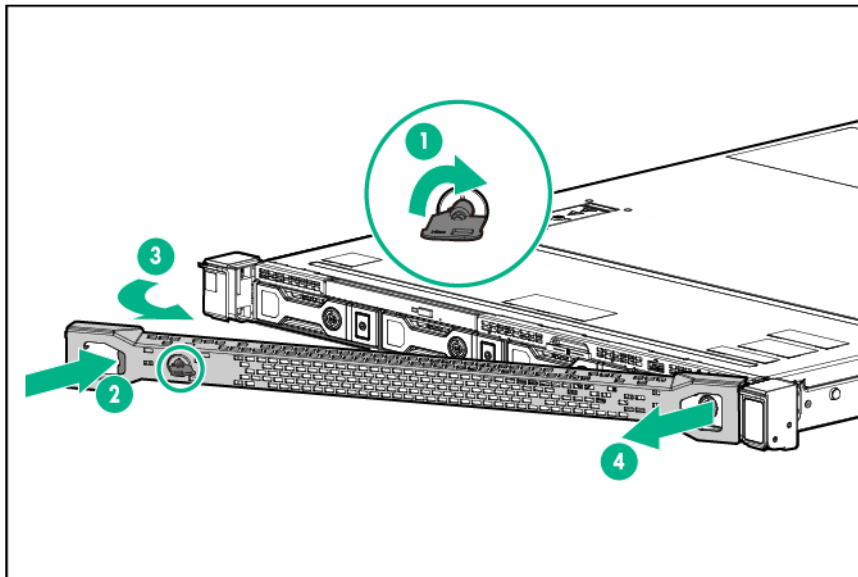

Remove the access panel

- ⚠ WARNING:** To reduce the risk of personal injury from hot surfaces, allow the drives and the internal system components to cool before touching them.

CAUTION: To prevent damage to electrical components, take the appropriate anti-static precautions before beginning any installation, removal, or replacement procedure. Improper grounding can cause electrostatic discharge.

CAUTION: Do not operate the server for long periods with the access panel open or removed. Operating the server in this manner results in improper airflow and improper cooling that can lead to thermal damage.

1. Power down the server (on page 15).
2. If you are performing a non-hot-plug procedure, remove all power:
 - a. Disconnect each power cord from the power source.
 - b. Disconnect each power cord from the server.
3. Do one of the following:
 - o Extend the server from the rack (on page 15).
 - o Remove the server from the rack (on page 18).
4. Open the access panel latch, slide the access panel to the rear of the chassis, and then remove the access panel.

If the access panel latch is locked, use a T-15 Torx screwdriver to unlock the latch.

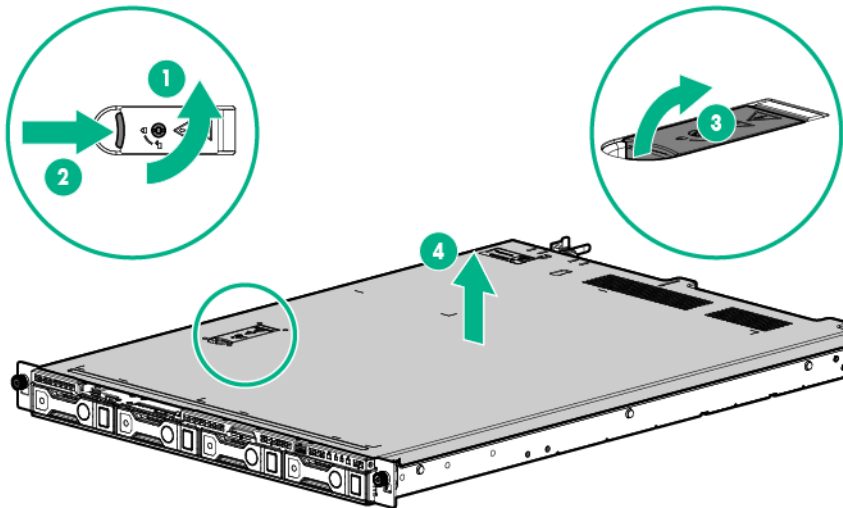

Install the access panel

1. Place the access panel on top of the server with the access panel latch open. Allow the panel to extend past the rear of the server by approximately 1.25 cm (0.5 inch).
2. Close the access panel latch. The access panel slides to a closed position.
3. Use a T-15 Torx screwdriver to tighten the access panel latch screw.

Remove the air baffle

CAUTION: For proper cooling, do not operate the server without the access panel, baffles, expansion slot covers, or blanks installed. If the server supports hot-plug components, minimize the amount of time the access panel is open.

To remove the component:

1. Power down the server (on page 15).
2. If you are performing a non-hot-plug procedure, remove all power:
 - a. Disconnect each power cord from the power source.
 - b. Disconnect each power cord from the server.
3. Do one of the following:
 - o Extend the server from the rack (on page 15).
 - o Remove the server from the rack (on page 18).
4. Remove the access panel (on page 18).
5. Remove the air baffle.

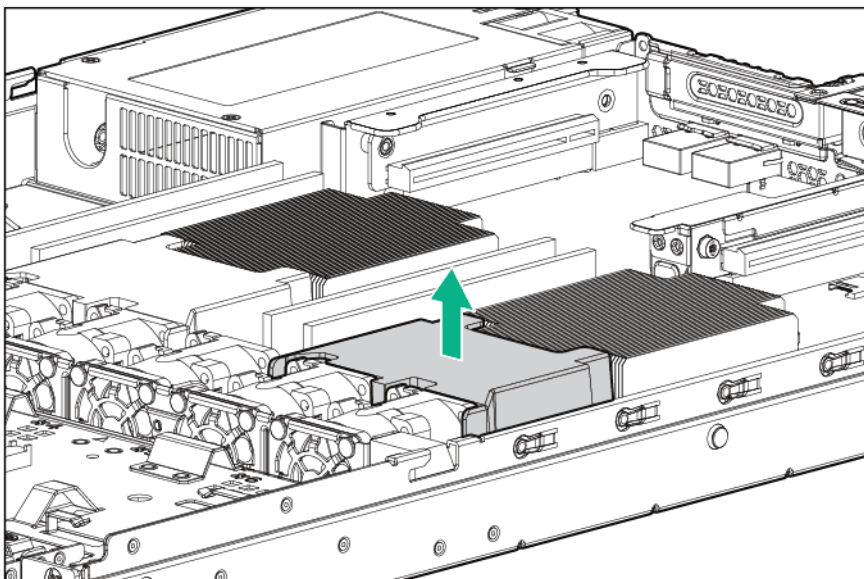

Install the air baffle

- △ **CAUTION:** For proper cooling, do not operate the server without the access panel, baffles, expansion slot covers, or blanks installed. If the server supports hot-plug components, minimize the amount of time the access panel is open.

To install the component:

1. Install the air baffle.

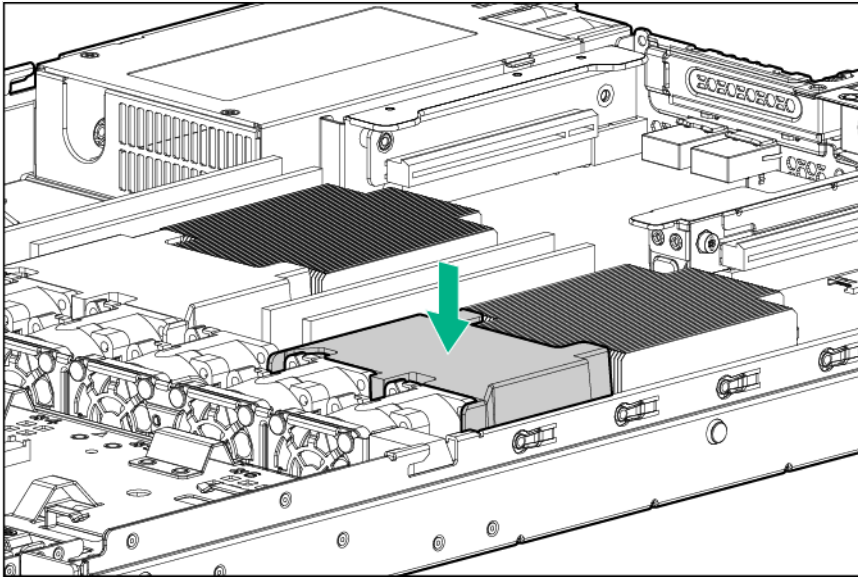

2. Install the access panel (on page 19).
3. Do one of the following:
 - o Slide the server into the rack.
 - o Install the server into the rack.
4. Power up the server (on page 15).

Remove the PCI riser cage

⚠ WARNING: To reduce the risk of personal injury from hot surfaces, allow the drives and the internal system components to cool before touching them.

⚠ CAUTION: To prevent damage to the server or expansion boards, power down the server, and disconnect all power cords before removing or installing the PCI riser cage.

1. Power down the server (on page 15).
2. Remove all power:
 - a. Disconnect each power cord from the power source.
 - b. Disconnect each power cord from the server.
3. Do one of the following:
 - o Extend the server from the rack (on page 15).
 - o Remove the server from the rack (on page 18).
4. Remove the access panel (on page 18).
5. Disconnect all cables connected to existing expansion boards.
6. Remove the secondary PCI riser cage or PCI blank.

- o Secondary PCI riser cage

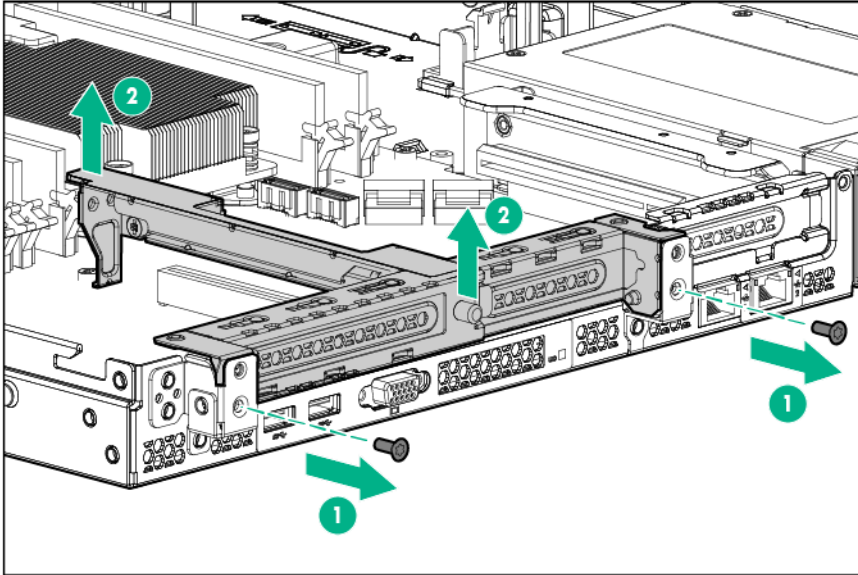

- o PCI blank

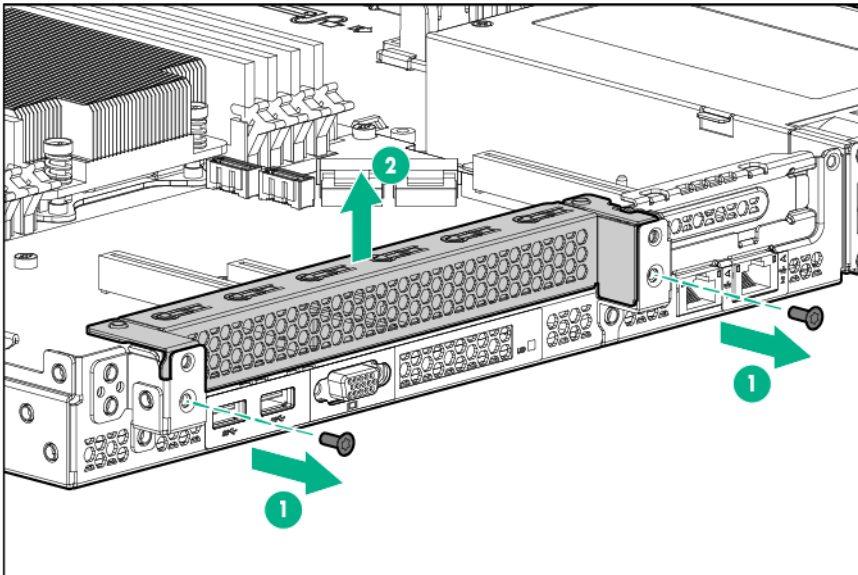

7. Remove any expansion boards installed in the primary riser cage.

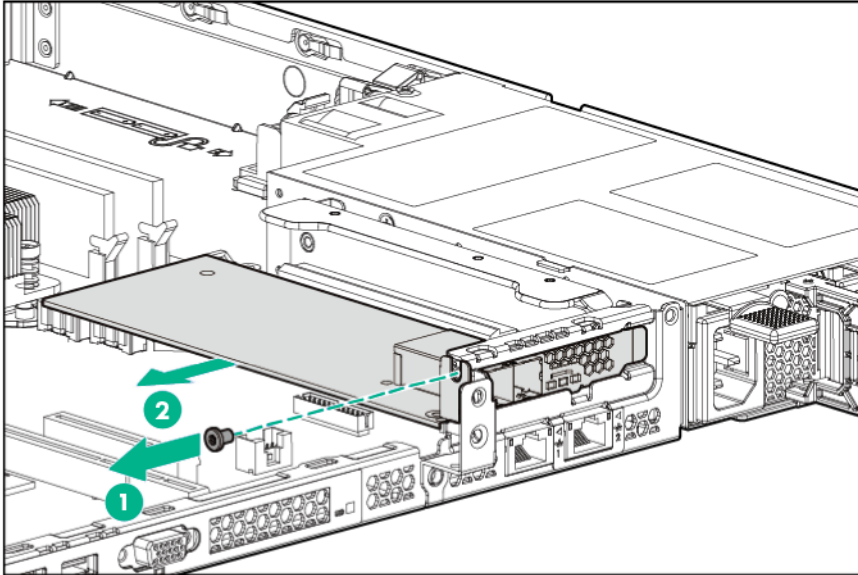

8. Remove the primary PCI riser cage.

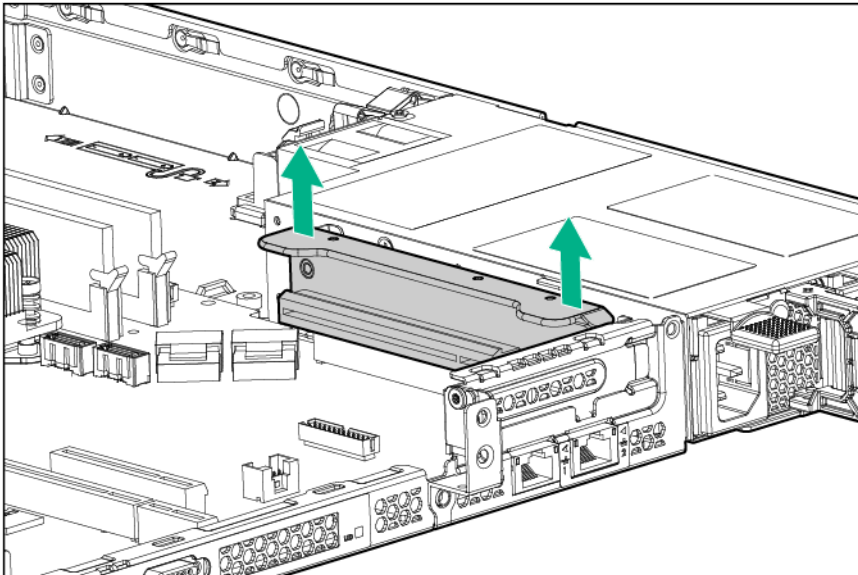

Install the PCI riser cage

⚠ CAUTION: To prevent damage to the server or expansion boards, power down the server, and disconnect all power cords before removing or installing the PCI riser cage.

To install the component:

1. Align the PCI riser board with the corresponding connectors on the system board, and then press down the PCI riser cage.

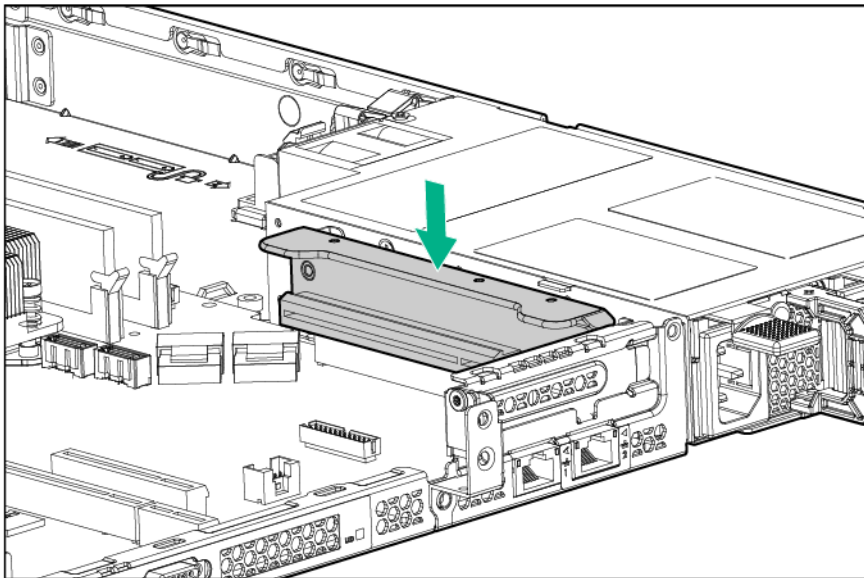

2. If installing the secondary PCI riser cage, remove the PCI blank.

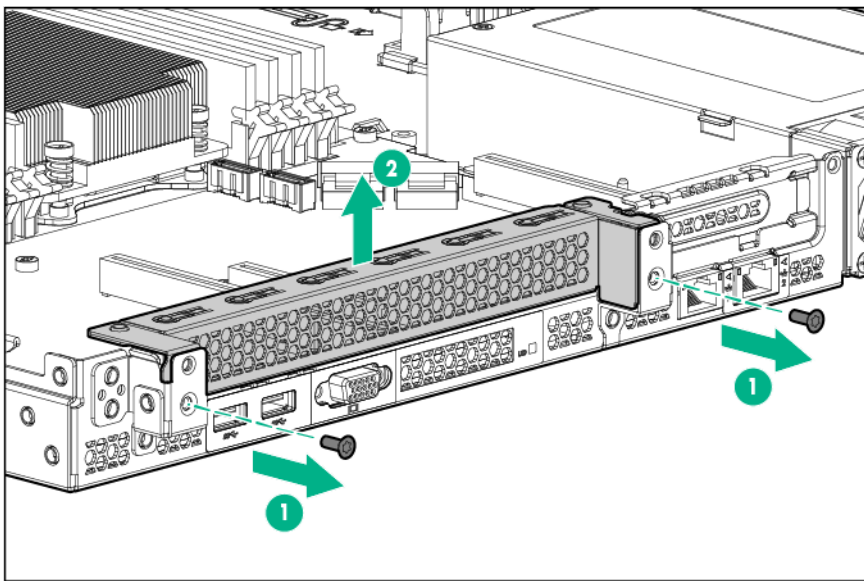

Retain the blank and screws for future use.

3. Align the PCI riser board with the corresponding connectors on the system board, and then press down the PCI riser cage.

4. Tighten the two screws to secure the cage.

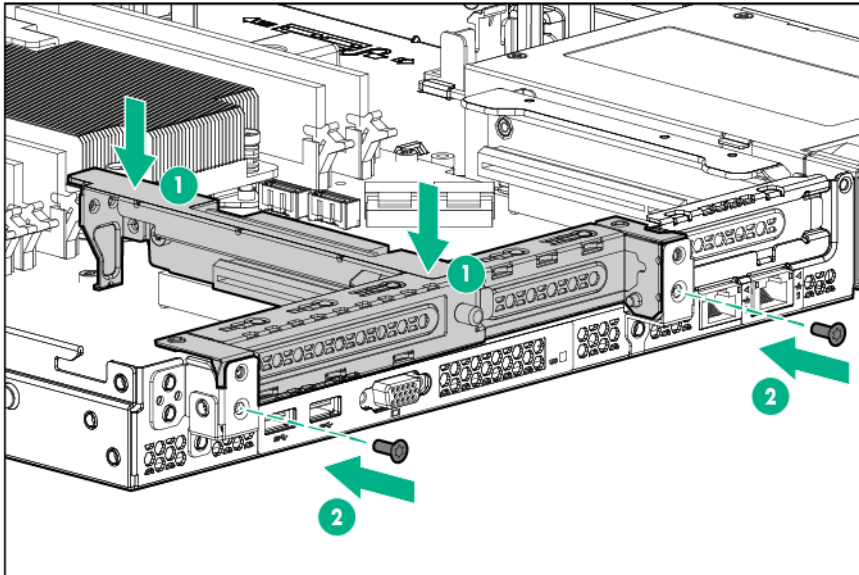

5. Install the access panel (on page 19).
6. Do one of the following:
 - o Slide the server into the rack.
 - o Install the server into the rack.
7. Power up the server (on page 15).

Setup

Optional services

Delivered by experienced, certified engineers, HPE support services help you keep your servers up and running with support packages tailored specifically for HPE ProLiant systems. HPE support services let you integrate both hardware and software support into a single package. A number of service level options are available to meet your business and IT needs.

HPE support services offer upgraded service levels to expand the standard product warranty with easy-to-buy, easy-to-use support packages that will help you make the most of your server investments. Some of the HPE support services for hardware, software or both are:

- Foundation Care – Keep systems running.
 - 6-Hour Call-to-Repair
 - 4-Hour 24x7
 - Next Business Day
- Proactive Care – Help prevent service incidents and get you to technical experts when there is one.
 - 6-Hour Call-to-Repair
 - 4-Hour 24x7
 - Next Business Day
- Startup and implementation services for both hardware and software
- HPE Education Services – Help train your IT staff.

For more information on HPE support services, see the Hewlett Packard Enterprise website (<http://www.hpe.com/services>).

Optimum environment

When installing the server in a rack, select a location that meets the environmental standards described in this section.

Space and airflow requirements

To allow for servicing and adequate airflow, observe the following space and airflow requirements when deciding where to install a rack:

- Leave a minimum clearance of 63.5 cm (25 inches) in front of the rack.
- Leave a minimum clearance of 76.2 cm (30 inches) behind the rack.
- Leave a minimum clearance of 121.9 cm (48 inches) from the back of the rack to the back of another rack or row of racks.

Hewlett Packard Enterprise servers draw in cool air through the front and expel warm air through the rear. Therefore, the front and rear rack doors must be adequately ventilated to allow ambient room air to enter the cabinet, and the rear door must be adequately ventilated to allow the warm air to escape from the cabinet.

-
- △ **CAUTION:** To prevent improper cooling and damage to the equipment, do not block the ventilation openings.
-

When vertical space in the rack is not filled by a server or rack component, the gaps between the components might cause changes in airflow through the rack and across the servers. To maintain airflow cover all gaps with blanking panels.

- △ **CAUTION:** Always use blanking panels to fill empty vertical spaces in the rack. This arrangement ensures proper airflow. Using a rack without blanking panels results in improper cooling that can lead to thermal damage.
-

The 9000 and 10000 series racks provide proper server cooling from flow-through perforations in the front and rear doors that provide 64% open area for ventilation.

- △ **CAUTION:** When using a Compaq branded 7000 series rack, install the high airflow rack door insert (PN 327281-B21 for 42U rack, PN 157847-B21 for 22U rack) to provide proper front-to-back airflow and cooling.
-
- △ **CAUTION:** If a third-party rack is used, observe the following additional requirements to ensure adequate airflow and to prevent damage to the equipment:
- Front and rear doors—If the 42U rack includes closing front and rear doors, you must allow 5,350 sq cm (830 sq in) of holes evenly distributed from top to bottom to permit adequate airflow (equivalent to the required 64 percent open area for ventilation).
 - Side—The clearance between the installed rack component and the side panels of the rack must be a minimum of 7 cm (2.75 in).
-

Temperature requirements

To ensure continued safe and reliable equipment operation, install or position the system in a well-ventilated, climate-controlled environment.

The maximum recommended ambient operating temperature (TMRA) for most server products is 35°C (95°F). The temperature in the room where the rack is located must not exceed 35°C (95°F).

- △ **CAUTION:** To reduce the risk of damage to the equipment when installing third-party options:
- Do not permit optional equipment to impede airflow around the server or to increase the internal rack temperature beyond the maximum allowable limits.
 - Do not exceed the manufacturer's TMRA.
-

Power requirements

Installation of this equipment must comply with local and regional electrical regulations governing the installation of information technology equipment by licensed electricians. This equipment is designed to operate in installations covered by NFPA 70, 1999 Edition (National Electric Code) and NFPA-75, 1992 (code for Protection of Electronic Computer/Data Processing Equipment). For electrical power ratings on options, refer to the product rating label or the user documentation supplied with that option.

- △ **WARNING:** To reduce the risk of personal injury, fire, or damage to the equipment, do not overload the AC supply branch circuit that provides power to the rack. Consult the electrical authority having jurisdiction over wiring and installation requirements of your facility.
-
- △ **CAUTION:** Protect the server from power fluctuations and temporary interruptions with a regulating uninterruptible power supply. This device protects the hardware from damage caused by power surges and voltage spikes and keeps the system in operation during a power failure.
-

When installing more than one server, you might need to use additional power distribution devices to safely provide power to all devices. Observe the following guidelines:

- Balance the server power load between available AC supply branch circuits.
- Do not allow the overall system AC current load to exceed 80% of the branch circuit AC current rating.
- Do not use common power outlet strips for this equipment.
- Provide a separate electrical circuit for the server.





For more information on the hot-plug power supply and calculators to determine server power consumption in various system configurations, see the Hewlett Packard Enterprise Power Advisor website (<http://www.hpe.com/info/poweradvisor/online>).

Electrical grounding requirements

The server must be grounded properly for proper operation and safety. In the United States, you must install the equipment in accordance with NFPA 70, 1999 Edition (National Electric Code), Article 250, as well as any local and regional building codes. In Canada, you must install the equipment in accordance with Canadian Standards Association, CSA C22.1, Canadian Electrical Code. In all other countries, you must install the equipment in accordance with any regional or national electrical wiring codes, such as the International Electrotechnical Commission (IEC) Code 364, parts 1 through 7. Furthermore, you must be sure that all power distribution devices used in the installation, such as branch wiring and receptacles, are listed or certified grounding-type devices.





Because of the high ground-leakage currents associated with multiple servers connected to the same power source, Hewlett Packard Enterprise recommends the use of a PDU that is either permanently wired to the building's branch circuit or includes a nondetachable cord that is wired to an industrial-style plug. NEMA locking-style plugs or those complying with IEC 60309 are considered suitable for this purpose. Using common power outlet strips for the server is not recommended.

Server warnings and cautions

-
-  **WARNING:** This server is very heavy. To reduce the risk of personal injury or damage to the equipment:
- Observe local occupational health and safety requirements and guidelines for manual material handling.
 - Get help to lift and stabilize the product during installation or removal, especially when the product is not fastened to the rails. Hewlett Packard Enterprise recommends that a minimum of two people are required for all rack server installations. A third person may be required to help align the server if the server is installed higher than chest level.
 - Use caution when installing the server in or removing the server from the rack; it is unstable when not fastened to the rails.
-
-  **WARNING:** To reduce the risk of personal injury from hot surfaces, allow the drives and the internal system components to cool before touching them.
-
-  **WARNING:** To reduce the risk of personal injury, electric shock, or damage to the equipment, remove the power cord to remove power from the server. The front panel Power On/Standby button does not completely shut off system power. Portions of the power supply and some internal circuitry remain active until AC power is removed.
-
-  **CAUTION:** Protect the server from power fluctuations and temporary interruptions with a regulating uninterruptible power supply. This device protects the hardware from damage caused by power surges and voltage spikes and keeps the system in operation during a power failure.
-

-
-  **CAUTION:** Do not operate the server for long periods with the access panel open or removed. Operating the server in this manner results in improper airflow and improper cooling that can lead to thermal damage.
-

Rack warnings

-
-  **WARNING:** To reduce the risk of personal injury or damage to the equipment, be sure that:
- The leveling jacks are extended to the floor.
 - The full weight of the rack rests on the leveling jacks.
 - The stabilizing feet are attached to the rack if it is a single-rack installation.
 - The racks are coupled together in multiple-rack installations.
 - Only one component is extended at a time. A rack may become unstable if more than one component is extended for any reason.
-
-  **WARNING:** To reduce the risk of personal injury or equipment damage when unloading a rack:
- At least two people are needed to safely unload the rack from the pallet. An empty 42U rack can weigh as much as 115 kg (253 lb), can stand more than 2.1 m (7 ft) tall, and might become unstable when being moved on its casters.
 - Never stand in front of the rack when it is rolling down the ramp from the pallet. Always handle the rack from both sides.
-
-  **WARNING:** To reduce the risk of personal injury or damage to the equipment, adequately stabilize the rack before extending a component outside the rack. Extend only one component at a time. A rack may become unstable if more than one component is extended.
-
-  **WARNING:** When installing a server in a telco rack, be sure that the rack frame is adequately secured at the top and bottom to the building structure.
-

Identifying the contents of the server shipping carton

Unpack the server shipping carton and locate the materials and documentation necessary for installing the server. All the rack mounting hardware necessary for installing the server into the rack is included with the rack or the server.

The contents of the server shipping carton include:

- Server
- Power cord
- Rack rail hook-and-loop strap
- Printed setup documentation
- Rack mounting hardware kit and documentation (optional)

You need the following items for some procedures:

- T-25 Torx screwdriver (to loosen the shipping screws located inside the server quick-release latch rack ears)
- T-10/T-15 Torx screwdriver
- Hardware options

Installing hardware options

Install any hardware options before initializing the server. For options installation information, see the option documentation. For server-specific information, see "Hardware options installation (on page 36)."

Installing the server into the rack

To install the server into a rack with square, round, or threaded holes, refer to the instructions that ship with the rack hardware kit.

If you are installing the server into a telco rack, order the appropriate option kit at the RackSolutions.com website (<http://www.racksolutions.com/hp>). Follow the server-specific instructions on the website to install the rack brackets.



WARNING: This server is very heavy. To reduce the risk of personal injury or damage to the equipment:

- Observe local occupational health and safety requirements and guidelines for manual material handling.
- Get help to lift and stabilize the product during installation or removal, especially when the product is not fastened to the rails. Hewlett Packard Enterprise recommends that a minimum of two people are required for all rack server installations. A third person may be required to help align the server if the server is installed higher than chest level.
- Use caution when installing the server in or removing the server from the rack; it is unstable when not fastened to the rails.



CAUTION: Always plan the rack installation so that the heaviest item is on the bottom of the rack. Install the heaviest item first, and continue to populate the rack from the bottom to the top.

To install the server in a Hewlett Packard Enterprise, Compaq-branded, Telco, or a third-party rack:

1. Install the server and cable management arm option into the rack. See the documentation that ships with the Easy Install Rail Kit.
2. Connect peripheral devices to the server. For information on identifying connectors, see "Rear panel components."



WARNING: To reduce the risk of electric shock, fire, or damage to the equipment, do not plug telephone or telecommunications connectors into RJ-45 connectors.

For a server using a non-hot-plug power supply:

3. To prevent the accidental disconnection of the power cord when sliding the server into and from the rack, secure the power cord through the strain relief clip:

- a. If the clip is positioned too near the power cord that it blocks the power cord plug connection, slide the clip backward.

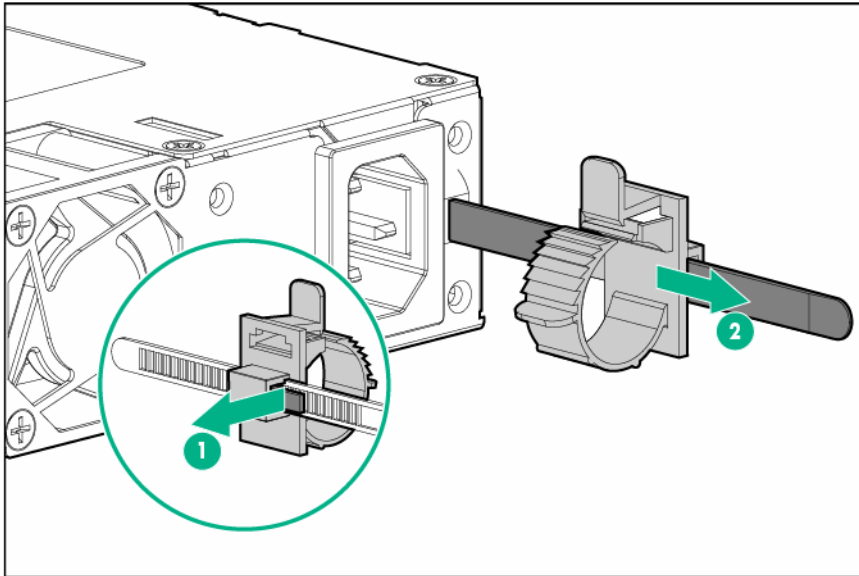

- b. Connect the power cord to the server.
c. Press the top part of the clip, and then pull the clip open.
d. Position the power cord inside the clip, and then close the clip.

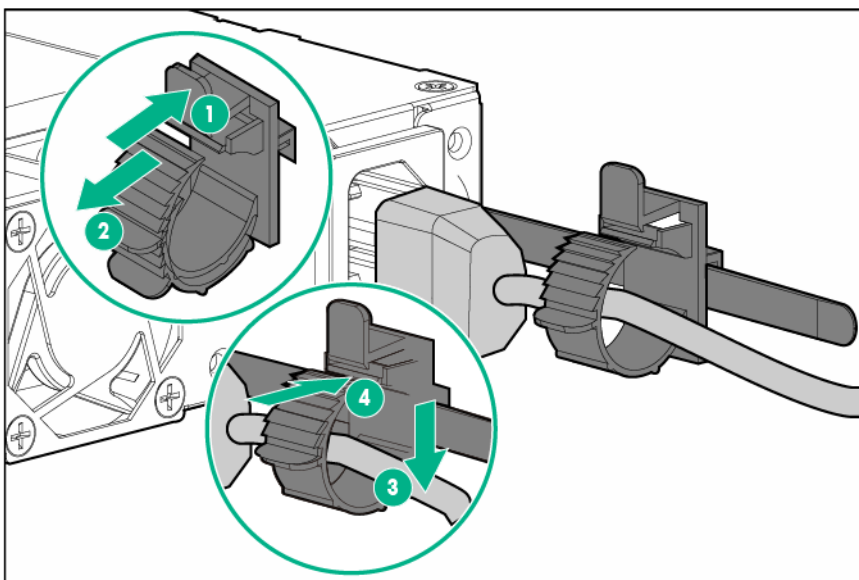

- e. Slide the clip forward until it is flush against the edge of the power cord plug.

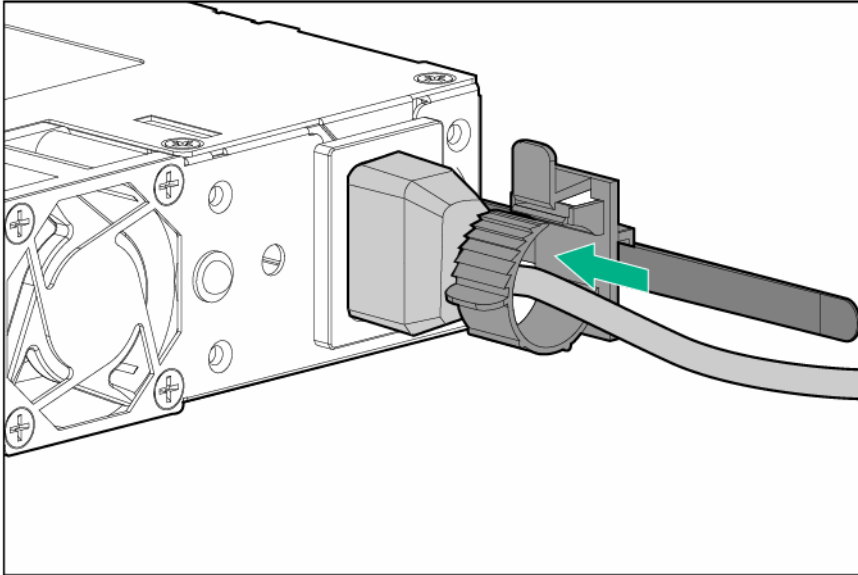

For a server using a hot-plug power supply:

- 4. To prevent accidental power cord disconnection when sliding the server in and out of the rack, secure the power cord in the strain relief strap attached to the power input module handle:
 - a. Unwrap the strain relief strap from the power input module handle.

CAUTION: Avoid tight bend radii to prevent damaging the internal wires of a power cord or a server cable. Never bend power cords and server cables tight enough to cause a crease in the sheathing.

- b. Bend the plug end of the power cord in the position shown in the following image.

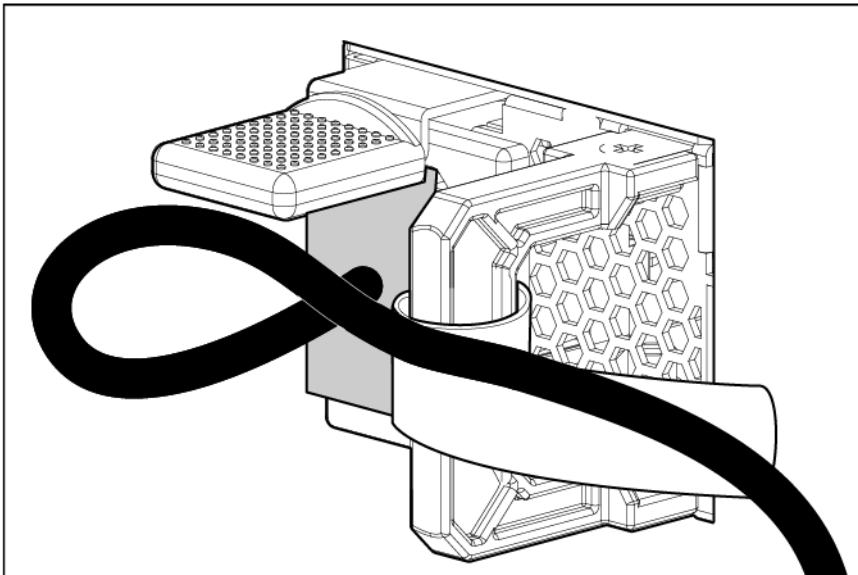

- c. Secure the power cord with the strain relief strap.

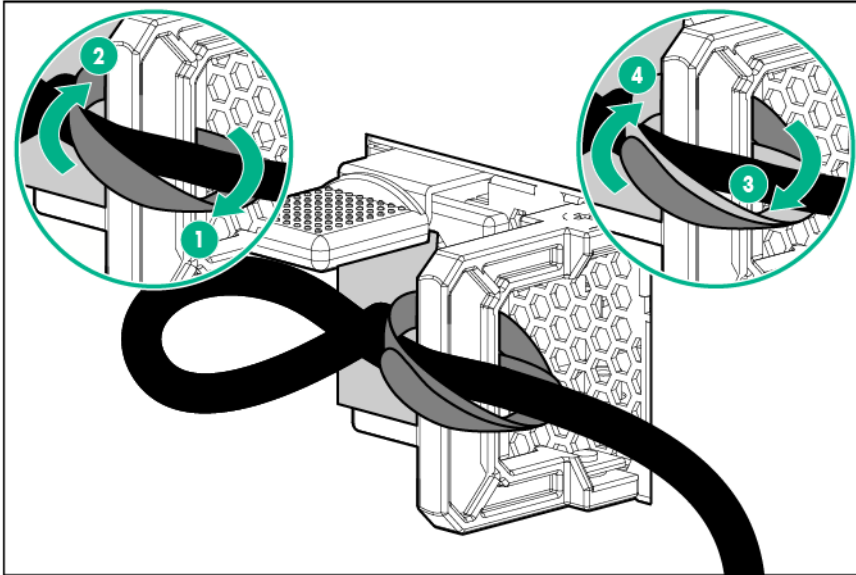

5. Employ best practices to route and manage the power cords and other cables in the server rear panel.



IMPORTANT: When using cable management arm components, be sure to leave enough slack in each of the cables to prevent damage to the cables when the server is extended from the rack.

6. Use the hook-and-loop strap included in the server shipping carton to secure the power cords and the other rear panel cables to the rack rail. For detailed instructions, see "Installing the rack rail hook-and-loop strap (on page 33)."
7. Connect the power cord to the power source.



WARNING: To reduce the risk of electric shock or damage to the equipment:

- Do not disable the power cord grounding plug. The grounding plug is an important safety feature.
- Plug the power cord into a grounded (earthed) electrical outlet that is easily accessible at all times.
- Unplug the power cord from the power supply to disconnect power to the equipment.
- Do not route the power cord where it can be walked on or pinched by items placed against it. Pay particular attention to the plug, electrical outlet, and the point where the cord extends from the server.

Installing the rack rail hook-and-loop strap

The rack rail hook-and-loop strap can be installed on either the left or right rack rail. Hewlett Packard Enterprise recommends installing it on the left rack rail for better cable management.

To install the rack rail hook-and-loop strap:

1. Install the server into the rack.
2. Install the rack rail hook-and-loop strap:
 - a. Hold the rear panel cables against the rack rail, and then wrap the strap around the rack rail.



CAUTION: To prevent thermal or mechanical obstruction on full-length servers installed in the rack, the extra length and buckle part of the strap must be facing the outside of the rack rail.

- b. Loop the end of the hook-and-loop strap through the buckle.

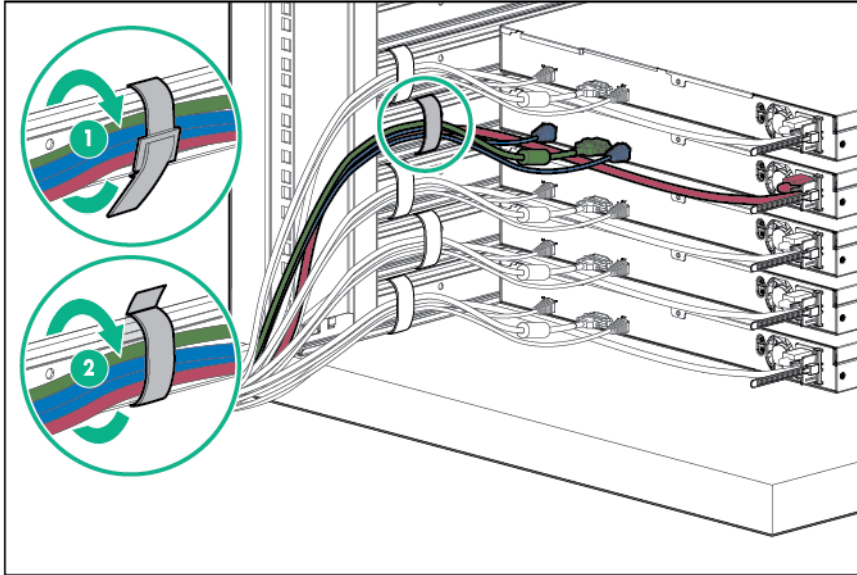

When multiple hook-and-loop straps are used in the same rack, stagger the strap location, so that the straps are adjacent to each other when viewed from top to bottom. This positioning will enable the rack rail to slide easily in and out of the rack.

Installing the operating system

This ProLiant server does not ship with provisioning media. Everything needed to manage and install the system software and firmware is preloaded on the server.

To operate properly, the server must have a supported operating system. Attempting to run an unsupported operating system can cause serious and unpredictable results. For the latest information on operating system support, see the Hewlett Packard Enterprise website (<http://www.hpe.com/info/supportos>).

Failure to observe UEFI requirements for ProLiant Gen9 servers can result in errors installing the operating system, failure to recognize boot media, and other boot failures. For more information on these requirements, see the *HPE UEFI Requirements* on the Hewlett Packard Enterprise website (<http://www.hpe.com/support/Gen9UEFI>).

To install an operating system on the server, use one of the following methods:

- Intelligent Provisioning—For single-server deployment, updating, and provisioning capabilities.
To install an operating system on the server with Intelligent Provisioning (local or remote):
 - a. Connect the Ethernet cable between the network connector on the server and a network jack.
 - b. Press the Power On/Standby button.
 - c. During server POST, press **F10**.
 - d. Complete the initial Preferences and Registration portion of Intelligent Provisioning (on page 92).
 - e. At the 1 Start screen, click **Configure and Install**.
 - f. To finish the installation, follow the onscreen prompts. An Internet connection is required to update the firmware and systems software.
- Insight Control server provisioning—For multi-server remote OS deployment, use Insight Control server provisioning for an automated solution. For more information, see the Insight Control documentation on the Hewlett Packard Enterprise website (<http://www.hpe.com/info/insightcontrol/docs>).

For additional system software and firmware updates, download the Service Pack for ProLiant from the Hewlett Packard Enterprise website (<http://www.hpe.com/servers/spp/download>). Software and firmware must be updated before using the server for the first time, unless any installed software or components require an older version.

For more information, see "Keeping the system current (on page 99)."

For more information on using these installation methods, see the Hewlett Packard Enterprise website (<http://www.hpe.com/info/ilo>).

Powering on and selecting boot options in UEFI Boot Mode

On servers operating in UEFI Boot Mode, the boot controller and boot order are set automatically.

1. Press the Power On/Standby button.
2. During the initial boot:
 - To modify the server configuration ROM default settings, press the **F9** key in the ProLiant POST screen to enter the UEFI System Utilities screen. By default, the System Utilities menus are in the English language.
 - If you do not need to modify the server configuration and are ready to install the system software, press the **F10** key to access Intelligent Provisioning.

For more information on automatic configuration, see the UEFI documentation on the Hewlett Packard Enterprise website (<http://www.hpe.com/info/ProLiantUEFI/docs>).

Registering the server

To experience quicker service and more efficient support, register the product at the Hewlett Packard Enterprise Product Registration website (<http://www.hpe.com/info/register>).

Hardware options installation

Introduction

If more than one option is being installed, read the installation instructions for all the hardware options and identify similar steps to streamline the installation process.



WARNING: To reduce the risk of personal injury from hot surfaces, allow the drives and the internal system components to cool before touching them.



CAUTION: To prevent damage to electrical components, properly ground the server before beginning any installation procedure. Improper grounding can cause electrostatic discharge.

Security bezel option

The security bezel helps prevent unauthorized physical access to the front panel components.

The security bezel is only supported in servers using the quick-release latch rack ears.

Install the security bezel and then lock it with the key provided with the kit.

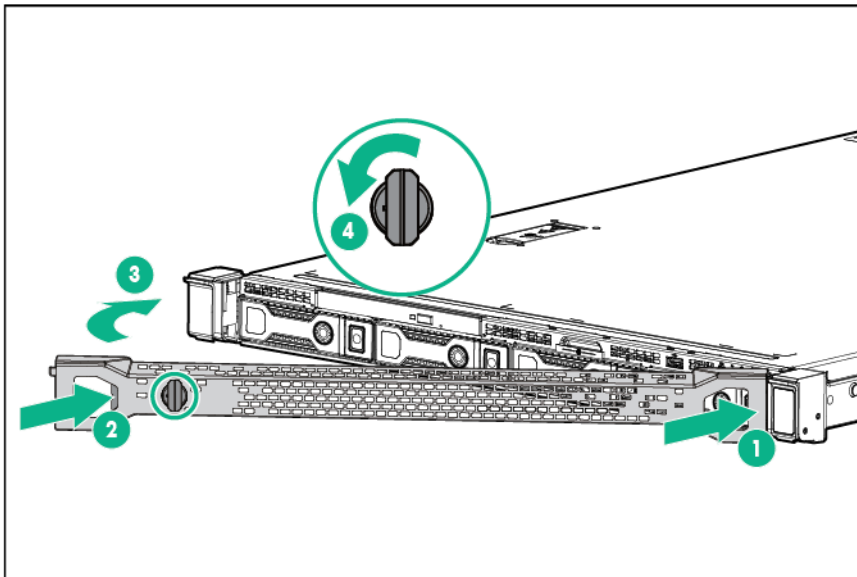

Drive options

The server supports up to four LFF hot-plug or non hot-plug drives.

The embedded storage controller supports SATA drive installation.

For SAS drive installation, install a Host Bus Adapter or a Smart Array Controller board option. For more information about product features, specifications, options, configurations, and compatibility, see the product QuickSpecs on the Hewlett Packard Enterprise website (<http://www.hpe.com/info/qs>).

Drive installation guidelines

When adding drives to the server, observe the following general guidelines:

- The system automatically sets all device numbers.
- Populate drive bays, based on the drive numbering sequence. Start from the drive bay with the lowest device number ("Drive numbering" on page 12).
- All drives grouped into the same drive array must meet the following criteria:
 - They must be either all SAS or all SATA.
 - They must be either all hard drives or all solid state drives.
 - Drives should be the same capacity to provide the greatest storage space efficiency when drives are grouped together into the same drive array.

Installing a non-hot-plug drive

CAUTION: To prevent improper cooling and thermal damage, do not operate the server unless all bays are populated with either a component or a blank.

To install the component:

1. Power down the server (on page 15).
2. Remove all power:
 - a. Disconnect each power cord from the power source.
 - b. Disconnect each power cord from the server.
3. If installed, remove the security bezel ("Remove the security bezel (optional)" on page 18).
4. Remove the drive carrier.

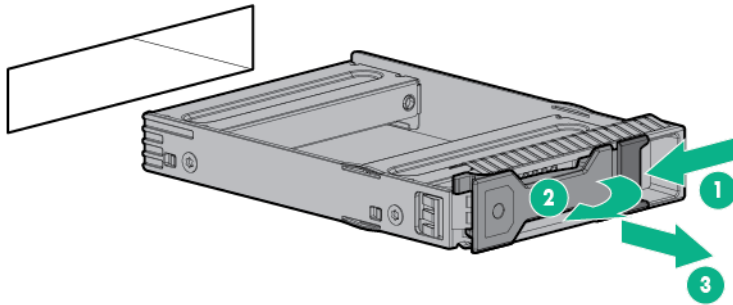

5. Remove the two metal brackets from the drive carrier.

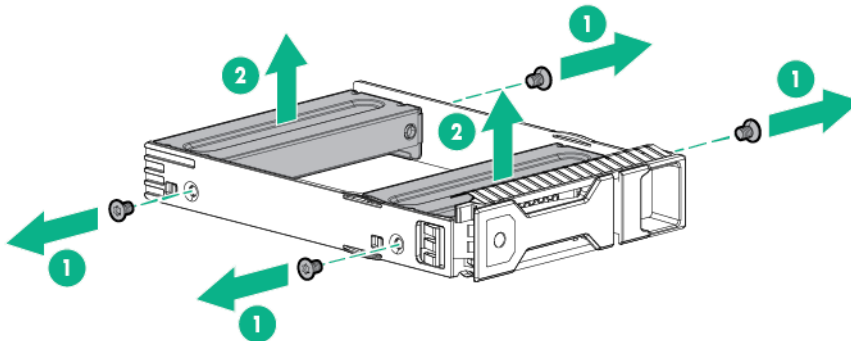

6. Install the drive in the carrier.

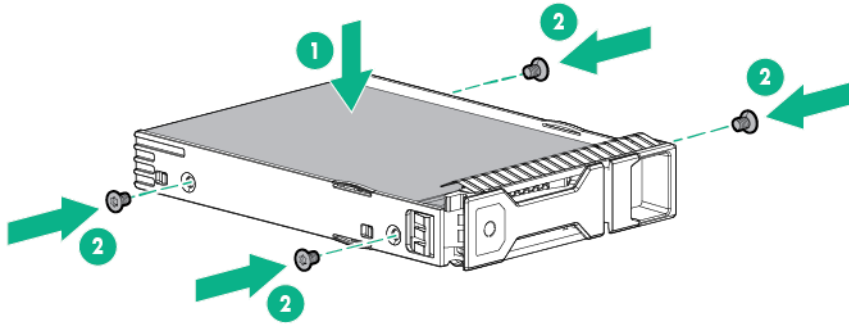

7. Install the drive.

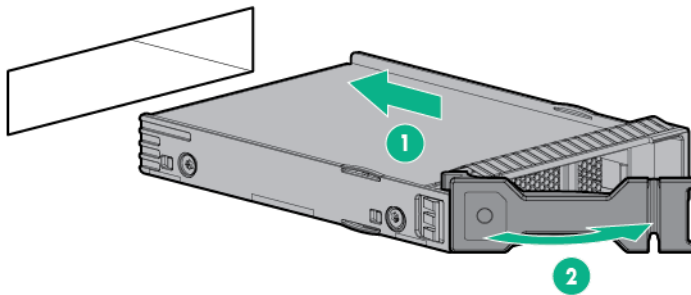

CAUTION: To prevent improper cooling and thermal damage, do not operate the server unless all bays are populated with either a component or a blank.

8. If removed, install the security bezel ("Security bezel option" on page 36).
9. Connect each power cord to the server.
10. Connect each power cord to the power source.
11. Power up the server (on page 15).

To configure arrays, see the *HPE Smart Storage Administrator User Guide* on the Hewlett Packard Enterprise website (<http://www.hpe.com/info/smartstorage/docs>).

Installing a hot-plug drive

CAUTION: To prevent improper cooling and thermal damage, do not operate the server unless all bays are populated with either a component or a blank.

To install the component:

1. If installed, remove the security bezel ("Remove the security bezel (optional)" on page 18).

2. Remove the drive blank.

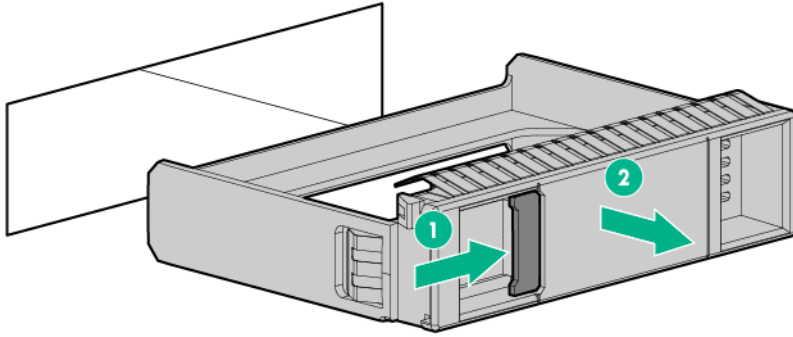

3. Prepare the drive.

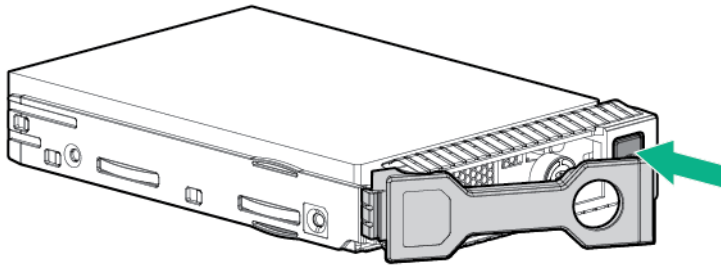

4. Install the drive.

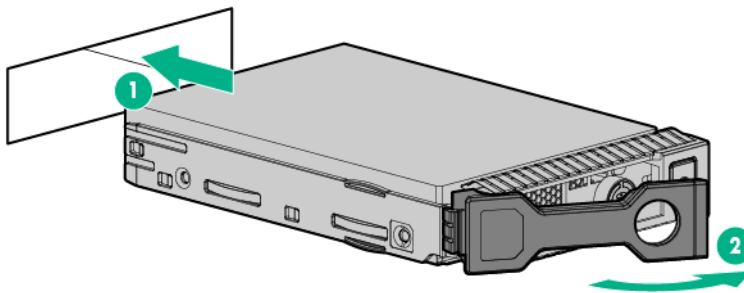

5. Determine the status of the drive from the drive LED definitions ("[Hot-plug drive LED definitions](#)" on page 13).
6. If removed, install the security bezel ("[Security bezel option](#)" on page 36).

To configure arrays, see the *HPE Smart Storage Administrator User Guide* on the Hewlett Packard Enterprise website (<http://www.hpe.com/info/smartstorage/docs>).

Storage controller options

The server ships with an embedded Dynamic Smart Array B140i Controller. This embedded controller is supported in UEFI Boot Mode only. For more information about the controller and its features, see the *HPE Dynamic Smart Array B140i RAID Controller User Guide* on the Hewlett Packard Enterprise website (<http://www.hpe.com/info/smartstorage/docs>).

Upgrade options exist for an integrated array controller. For a list of supported options, see the product QuickSpecs on the Hewlett Packard Enterprise website (<http://www.hpe.com/info/qs>).



To configure arrays, see the *HPE Smart Storage Administrator User Guide* on the Hewlett Packard Enterprise website (<http://www.hpe.com/info/smartstorage/docs>).

The server supports FBWC. FBWC consists of a cache module and a Smart Storage Battery Pack. The DDR cache module buffers and stores data being written by an integrated Gen9 P-series Smart Array Controller.

This server supports the 96-W Smart Storage Battery Pack. This battery pack can support up to 24 devices. Devices in this context refer to the Smart Array Controller or NVDIMM associated with the cache module.

The battery pack might have a low charge when installed. If the battery does have low charge, a POST error message appears when the server is powered up, indicating that the battery pack is temporarily disabled. No action is necessary. The internal circuitry automatically recharges the batteries and enables the battery pack. When the system is powered on this process might take approximately 2 hours.

If a system power failure occurs, a fully charged battery pack provides power for up to 150 seconds. During that interval, the controller transfers the cached data from DDR memory to flash memory, where the data remains indefinitely or until a controller retrieves the data. The data protection and the time limit also apply if a power outage occurs. When power is restored to the system, an initialization process writes the preserved data to the storage drives.

-
-  **CAUTION:** The cache module connector does not use the industry-standard DDR3 mini-DIMMs. Do not use the controller with cache modules designed for other controller models, because the controller can malfunction and you can lose data. Also, do not transfer this cache module to an unsupported controller model, because you can lose data.
-
-  **CAUTION:** To prevent a server malfunction or damage to the equipment, do not add or remove the battery pack while an array capacity expansion, RAID level migration, or stripe size migration is in progress.
-
-  **CAUTION:** After the server is powered down, wait for 30 seconds, and then check the amber LED before unplugging the cable from the cache module. If the amber LED flashes after 30 seconds, do not remove the cable from the cache module. The cache module is backing up data. Data will be lost if the cable is detached when the amber LED is still flashing.
-

Installing a storage controller and FBWC module

Install H240 and P440 cards in slot 1 of the primary PCI riser cage.

For more information about product features, specifications, options, configurations, and compatibility, see the product QuickSpecs on the Hewlett Packard Enterprise website (<http://www.hpe.com/info/gs>).



IMPORTANT: For additional installation and configuration information, see the documentation that ships with the option.

To install the component:

1. Back up all server data.
2. Power down the server (on page 15).
3. Remove all power:
 - a. Disconnect each power cord from the power source.
 - b. Disconnect each power cord from the server.
4. Do one of the following:
 - o Extend the server from the rack (on page 15).
 - o Remove the server from the rack (on page 18).
5. Remove the access panel (on page 18).

6. Remove the secondary PCI riser cage ("[Remove the PCI riser cage](#)" on page 21).

CAUTION: When connecting or disconnecting the cache module cable, the connectors on the cache module and cable are susceptible to damage. Avoid excessive force and use caution to avoid damage to these connectors.

7. If you intend to use an FBWC module, install the module on the storage controller. Depending on the controller model, the cable connector on the cache module might be facing up or down when the module is installed on the controller board.
 - a. Connect the cache module backup power cable to the module.

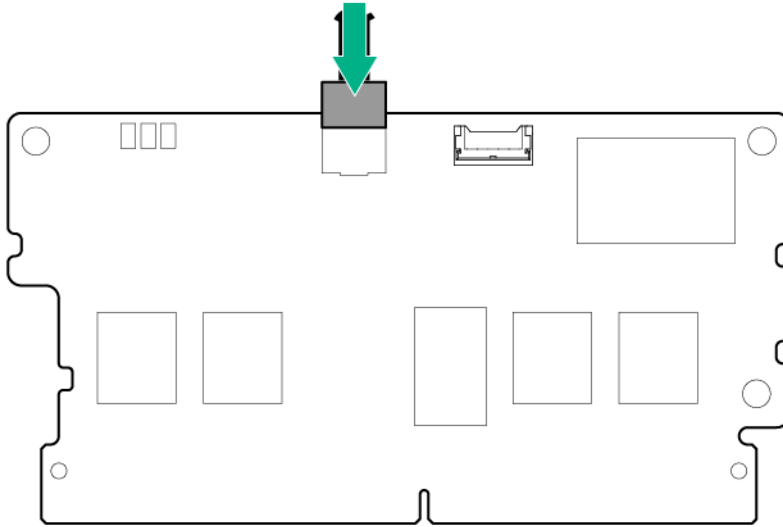

- b. Install the cache module on the storage controller.

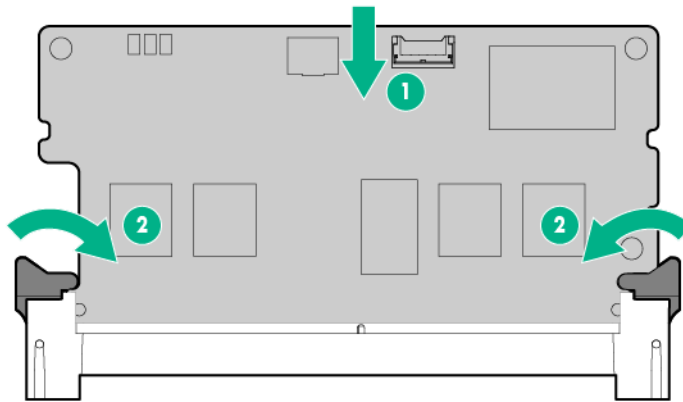

8. Install the storage controller.
H240 and P440 cards can only be installed in slot 1 of the primary PCI riser cage.
9. If you installed a cache module on the storage controller, connect the cache module cable to the system board connector. For cache module cabling information, see "[FBWC cabling](#) (on page 85)."
10. Connect all necessary internal cables to the storage controller. For internal drive cabling information, see "[Storage cabling](#) (on page 80)."
11. If you are planning to install a Smart Storage Battery, install it now ("[Installing a Smart Storage Battery](#)" on page 42).
12. Install the secondary PCI riser cage ("[Install the PCI riser cage](#)" on page 23).

13. Install the access panel (on page 19).
14. Do one of the following:
 - o Slide the server into the rack.
 - o Install the server into the rack.
15. Power up the server (on page 15).
16. If you are planning to install new drives, install them now.

For more information about the integrated storage controller and its features, select the relevant user documentation on the Hewlett Packard Enterprise website (<http://www.hpe.com/info/smartstorage/docs>).

To configure arrays, see the *HPE Smart Storage Administrator User Guide* on the Hewlett Packard Enterprise website (<http://www.hpe.com/info/smartstorage/docs>).

Installing a Smart Storage Battery

For more information about product features, specifications, options, configurations, and compatibility, see the product QuickSpecs on the Hewlett Packard Enterprise website (<http://www.hpe.com/info/gs>).

CAUTION: In systems that use external data storage, be sure that the server is the first unit to be powered down and the last to be powered back up. Taking this precaution ensures that the system does not erroneously mark the external drives as failed when the server is powered up.

To install the component:

1. Power down the server (on page 15).
2. Remove all power:
 - a. Disconnect each power cord from the power source.
 - b. Disconnect each power cord from the server.
3. Do one of the following:
 - o Extend the server from the rack (on page 15).
 - o Remove the server from the rack (on page 18).
4. Remove the access panel (on page 18).
5. Install the Smart Storage Battery:

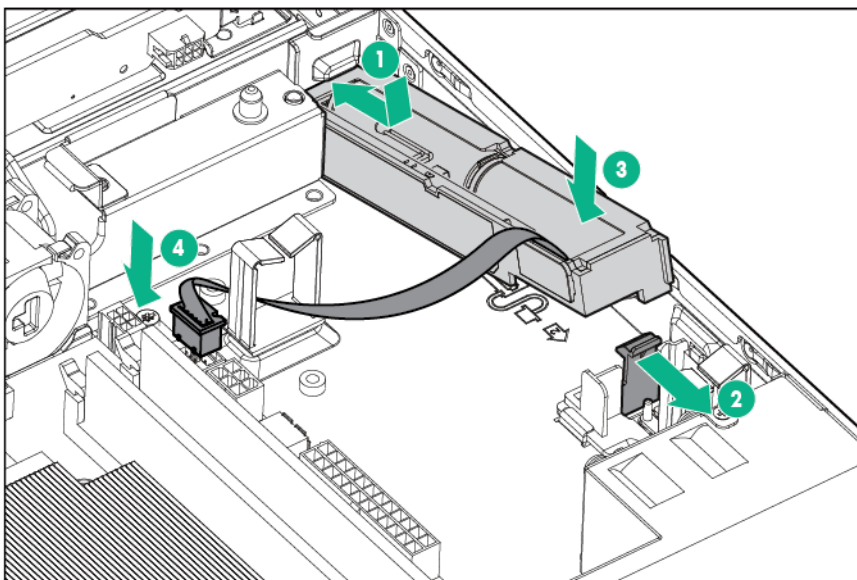

6. Install the access panel (on page 19).
7. Do one of the following:
 - o Slide the server into the rack.
 - o Install the server into the rack.
8. Power up the server (on page 15).

Drive cable options

Use these drive cable options to install a Host Bus Adapter or a Smart Array Controller board option.

For more information about product features, specifications, options, configurations, and compatibility, see the product QuickSpecs on the Hewlett Packard Enterprise website (<http://www.hpe.com/info/qs>).

Mini-SAS cable options

To connect the cable option:

1. Power down the server (on page 15).
2. Remove all power:
 - a. Disconnect each power cord from the power source.
 - b. Disconnect each power cord from the server.
3. Do one of the following:
 - o Extend the server from the rack (on page 15).
 - o Remove the server from the rack (on page 18).
4. Remove the access panel (on page 18).
5. Remove the secondary PCI riser cage ("Remove the PCI riser cage" on page 21).
6. Remove the baffle from the controller board.
7. Remove the existing full-height bracket on the controller board and install the low-profile bracket that ships with the option.
8. Disconnect the existing Mini-SAS cables from the system board and the drive backplane.
9. If you intend to use a cache module and Smart Storage Battery, install these options now. ("Storage controller options" on page 39)
10. Install the storage controller.
H240 and P440 cards can only be installed in slot 1 of the primary PCI riser cage.
11. Connect the common end of the Mini-SAS cable to the controller option.

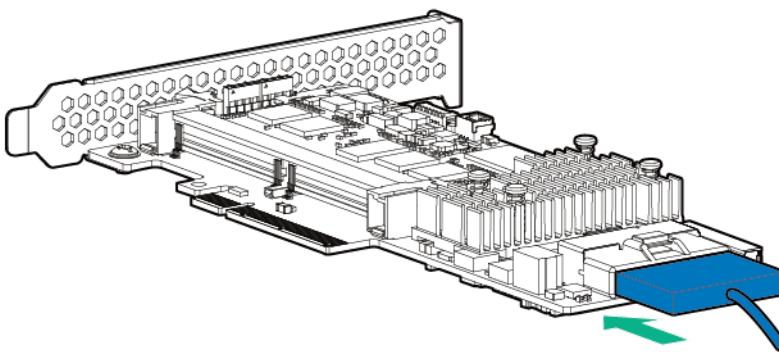

12. Install the secondary PCI riser cage ("Install the PCI riser cage" on page 23).

13. Route the Mini-SAS cables through the clip and connect the connectors to the drive backplane.
 - o H240 Host Bus Adapter to the 4 LFF drive backplane

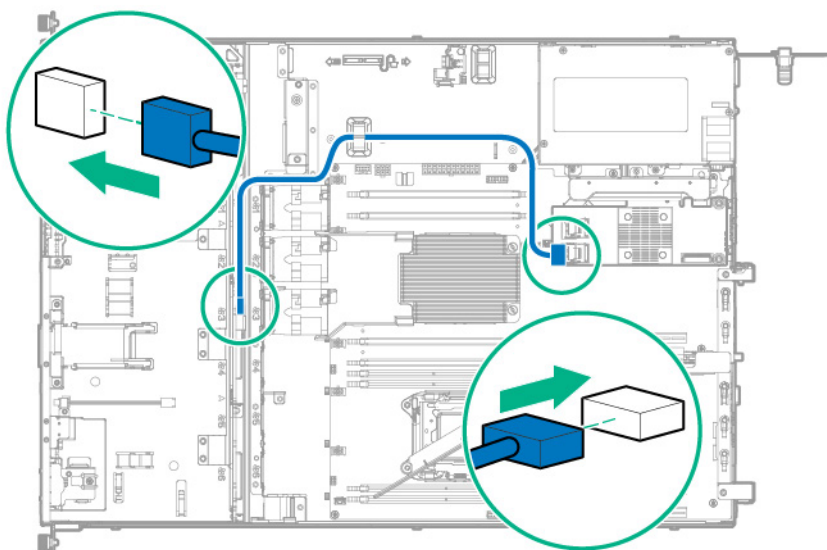

- o P440 Smart Array Controller to the 4 LFF drive backplane

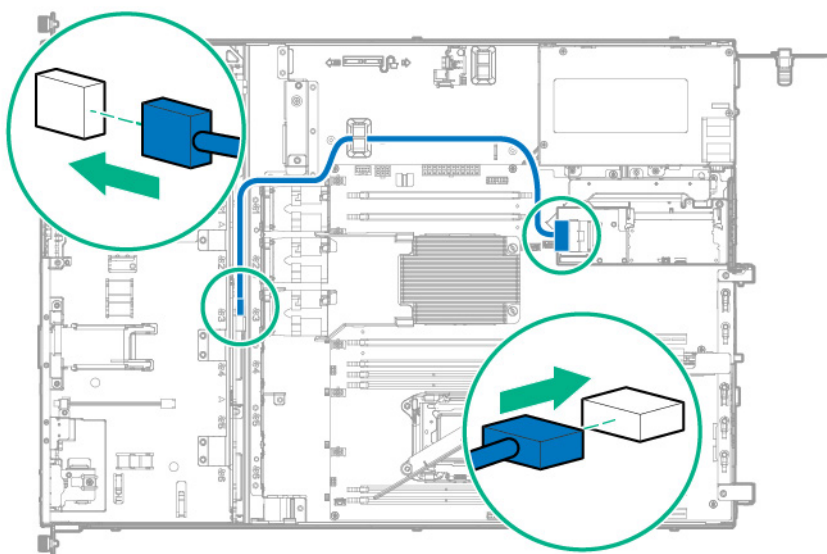

14. Connect the rest of the drive cables required in this drive configuration. For more information, see "Storage cabling (on page 80)."
15. Install the access panel (on page 19).
16. Install the server into the rack.
17. Power up the server (on page 15).

CAUTION: To prevent improper cooling and thermal damage, do not operate the server unless all bays are populated with either a component or a blank.

18. Install the drives.

Optical drive option

For more information about product features, specifications, options, configurations, and compatibility, see the product QuickSpecs on the Hewlett Packard Enterprise website (<http://www.hpe.com/info/gs>).

To install the component:

1. Power down the server (on page 15).
2. Remove all power:
 - a. Disconnect each power cord from the power source.
 - b. Disconnect each power cord from the server.
3. Do one of the following:
 - o Extend the server from the rack (on page 15).
 - o Remove the server from the rack (on page 18).
4. Remove the access panel (on page 18).
5. Remove the optical drive blank.
Retain the blank for future use.

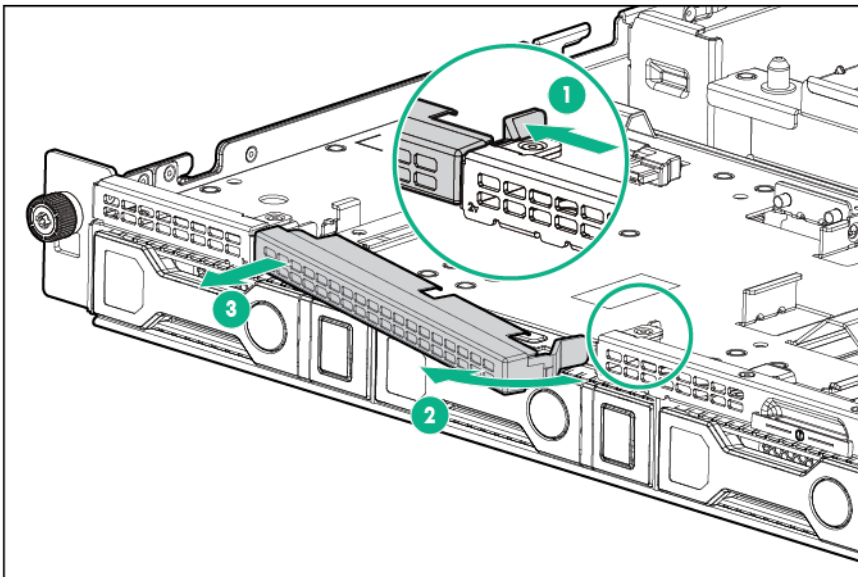

6. Install the optical drive into the bay.

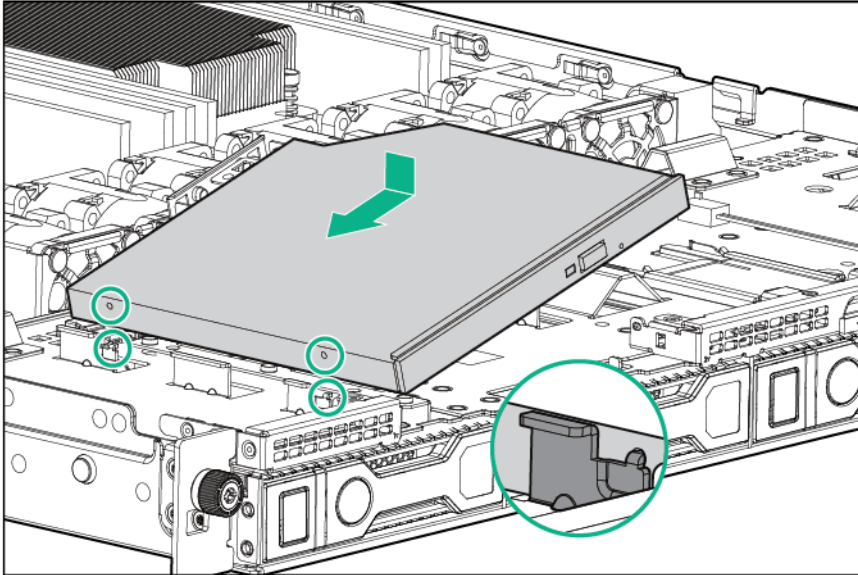

7. Connect the optical drive cable to the optical drive.
8. Route the optical drive cable through the cable clip, connect the cable to the system board SATA connector, and then connect the power cable to the system board power cable connector:

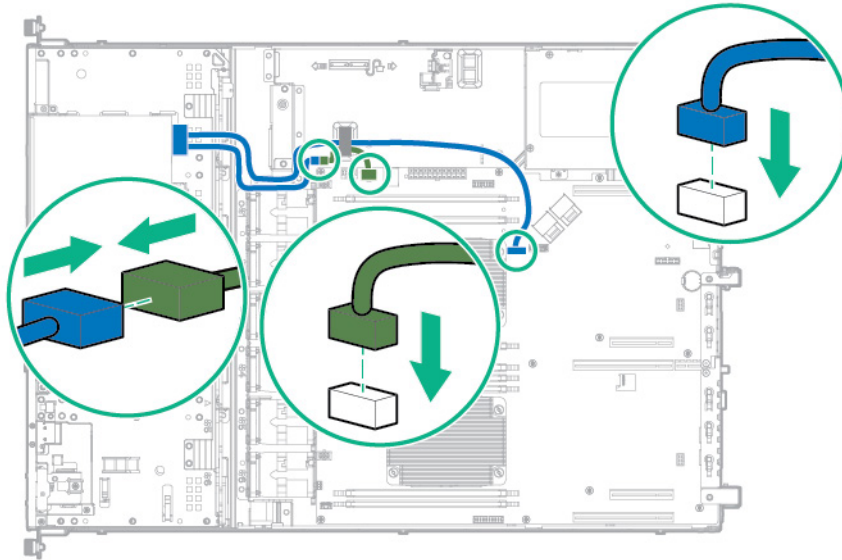

9. Install the access panel (on page 19).
10. Do one of the following:
 - o Slide the server into the rack.
 - o Install the server into the rack.
11. Power up the server (on page 15).

Redundant fan option

To provide sufficient airflow to the system if a fan rotor fails, the server supports redundant fans.

Fan population guidelines

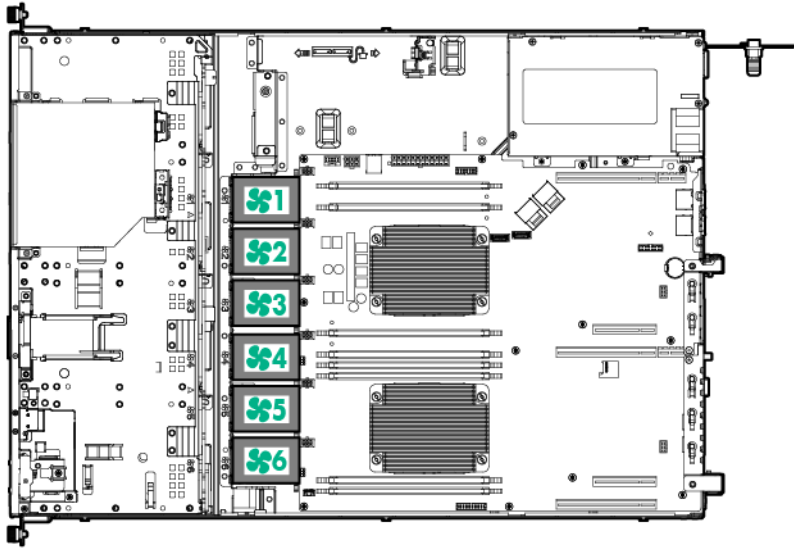

| Configuration | Fan bay 1 | Fan bay 2 | Fan bay 3 | Fan bay 4 | Fan bay 5 | Fan bay 6 |
|-------------------------------|-----------|-----------|-----------|-----------|-----------|-----------|
| One processor, non-redundant | Fan | Fan | Blank | Fan | Blank | Blank |
| One processor, redundant | Fan | Fan | Fan | Fan | Fan | Blank |
| Two processors, non-redundant | Fan | Fan | Blank | Fan | Blank | Fan |
| Two processors, redundant | Fan | Fan | Fan | Fan | Fan | Fan |

- In the redundant fan mode:
 - If one fan rotor fails, the system continues to operate without redundancy. This condition is indicated by a flashing amber Health LED.
 - If two fan rotors fail, the operating system shuts down.

Installing a hot-swap fan module

⚠ WARNING: To reduce the risk of personal injury from hot surfaces, allow the drives and the internal system components to cool before touching them.

To install the component:

1. Power down the server (on page 15).
2. Remove all power:
 - a. Disconnect each power cord from the power source.
 - b. Disconnect each power cord from the server.
3. Do one of the following:
 - Extend the server from the rack (on page 15).
 - Remove the server from the rack (on page 18).
4. Remove the access panel (on page 18).
5. Remove the air baffle (on page 19).

6. To determine which fan blanks need to be removed to install the additional fans, see "Fan population guidelines."
7. Remove the fan blank.

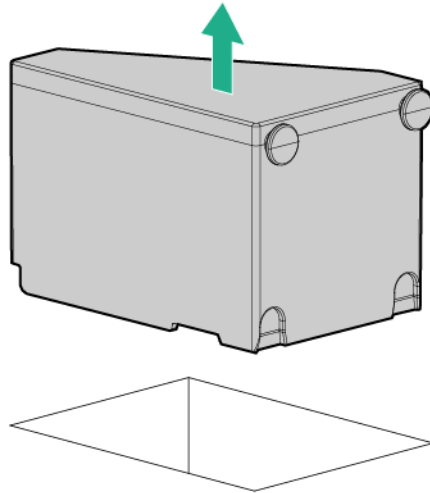

8. Install the fan.

CAUTION: The fan does not have a fan guard. Special attention is needed when removing or installing the fan to prevent finger injury.

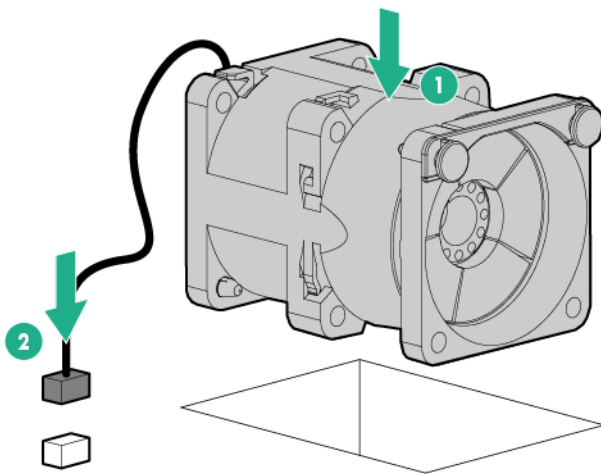

9. Connect the fan cable to the system board.

CAUTION: To prevent improper cooling and thermal damage, do not operate the server unless all bays are populated with either a component or a blank.

10. Install the air baffle (on page 20).
11. Install the access panel (on page 19).
12. Do one of the following:
 - o Slide the server into the rack.

- o Install the server into the rack.
13. Power up the server (on page 15).

Memory options



IMPORTANT: This server does not support mixing LRDIMMs and RDIMMs. Attempting to mix any combination of these DIMMs can cause the server to halt during BIOS initialization.

The memory subsystem in this server can support LRDIMMs or RDIMMs:

- RDIMMs offer address parity protection.
- LRDIMMs support higher densities than single-rank and dual-rank RDIMMs. This support enables you to install higher capacity DIMMs, resulting in higher system capacities and higher bandwidth.

All types are referred to as DIMMs when the information applies to all types. When specified as LRDIMM or RDIMM, the information applies to that type only. All memory installed in the server must be of the same type.

Memory-processor compatibility information

For the latest memory configuration information, see the product QuickSpecs on the Hewlett Packard Enterprise website (<http://www.hpe.com/info/gs>).

DIMM type

- Intel Xeon E5-2600 v3 processors are optimized for:
 - o Single-rank and dual-rank PC4-2133 (DDR4-2133) RDIMMs operating at up to 2133 MT/s
 - o Dual-rank and quad-rank PC4-2133 (DDR4-2133) LRDIMMs operating at up to 2133 MT/s
- Intel Xeon E5-2600 v4 processors are optimized for:
 - o Single-rank and dual-rank PC4-2400T (DDR4-2400) RDIMMs operating at up to 2400 MT/s
 - o Dual-rank PC4-2400T (DDR4-2400) LRDIMMs operating at up to 2400 MT/s

DIMM specifications

DIMM specifications - Intel Xeon E5-2600 v3 processor installed

| Type | Rank | Capacity (GB) | Native speed (MT/s) | Voltage |
|--------|--------|---------------|---------------------|---------|
| RDIMM | Single | 4 | 2133 | STD |
| RDIMM | Single | 8 | 2133 | STD |
| RDIMM | Dual | 8 | 2133 | STD |
| RDIMM | Dual | 16 | 2133 | STD |
| LRDIMM | Dual | 16 | 2133 | STD |
| RDIMM | Dual | 32 | 2133 | STD |
| LRDIMM | Quad | 32 | 2133 | STD |

DIMM specifications - Intel Xeon E5-2600 v4 processor installed

| Type | Rank | Capacity (GB) | Native speed (MT/s) | Voltage |
|--------|--------|---------------|---------------------|---------|
| RDIMM | Single | 8 | 2400 | STD |
| RDIMM | Single | 16 | 2400 | STD |
| RDIMM | Dual | 16 | 2400 | STD |
| RDIMM | Dual | 32 | 2400 | STD |
| LRDIMM | Dual | 32 | 2400 | STD |

Populated DIMM speed (MT/s)

Operating memory speed is a function of rated DIMM speed, the number of DIMMs installed per channel, processor model, and the speed selected in the BIOS/Platform Configuration (RBSU) of the UEFI System Utilities ("HPE UEFI System Utilities" on page 94).

Populated DIMM speed - Intel Xeon E5-2600 v3 processor installed

| Type | Rank | 1 DIMM per channel (MT/s) |
|--------|--------|---------------------------|
| RDIMM | Single | 2133 |
| RDIMM | Dual | 2133 |
| LRDIMM | Dual | 2133 |
| LRDIMM | Quad | 2133 |

Populated DIMM speed - Intel Xeon E5-2600 v4 processor installed

| Type | Rank | 1 DIMM per channel (MT/s) |
|--------|--------|---------------------------|
| RDIMM | Single | 2400 |
| RDIMM | Dual | 2400 |
| LRDIMM | Dual | 2400 |

Maximum memory capacity

Maximum memory capacity is a function of DIMM capacity, number of installed DIMMs, memory type, and number of installed processors.

Maximum memory capacity - Intel Xeon E5-2600 v3 processor installed

| DIMM type | DIMM rank | Capacity (GB) | Maximum capacity for one processor (GB) | Maximum capacity for two processors (GB) |
|-----------|-------------|---------------|---|--|
| RDIMM | Single-rank | 4 | 32 | 64 |
| RDIMM | Single-rank | 8 | 64 | 128 |
| RDIMM | Dual-rank | 8 | 64 | 128 |
| RDIMM | Dual-rank | 16 | 128 | 256 |
| LRDIMM | Dual-rank | 16 | 128 | 256 |
| RDIMM | Dual-rank | 32 | 256 | 512 |
| LRDIMM | Quad-rank | 32 | 256 | 512 |

Maximum memory capacity - Intel Xeon E5-2600 v4 processor installed

| DIMM type | DIMM rank | Capacity (GB) | Maximum capacity for one processor (GB) | Maximum capacity for two processors (GB) |
|-----------|-------------|---------------|---|--|
| RDIMM | Single-rank | 8 | 64 | 128 |
| RDIMM | Single-rank | 16 | 128 | 256 |
| RDIMM | Dual-rank | 16 | 128 | 256 |
| RDIMM | Dual-rank | 32 | 256 | 512 |
| LRDIMM | Dual-rank | 32 | 256 | 512 |

SmartMemory

SmartMemory authenticates and unlocks certain features available only on Qualified memory and verifies whether installed memory has passed Hewlett Packard Enterprise qualification and test processes.

Qualified memory is performance-tuned for ProLiant and BladeSystem servers and provides future enhanced support through Active Health and manageability software.

Memory subsystem architecture

The memory subsystem in this server is divided into channels. Each processor supports four channels, and each channel supports one DIMM slot.

| Channel | Population order | Slot number |
|---------|------------------|-------------|
| 1 | A | 1 |
| 2 | B | 2 |
| 3 | C | 4 |
| 4 | D | 3 |

DIMM slots are identified by number and by letter. Letters identify the population order. Slot numbers are reported by ROM messages during boot and are used for error reporting. For the DIMM slot locations, see "DIMM slot locations."

Single-, dual-, and quad-rank DIMMs

To understand and configure memory protection modes properly, an understanding of single-, dual-, and quad-rank DIMMs is helpful. Some DIMM configuration requirements are based on these classifications.

A single-rank DIMM has one set of memory chips that is accessed while writing to or reading from the memory. A dual-rank DIMM is similar to having two single-rank DIMMs on the same module, with only one rank accessible at a time. A quad-rank DIMM is, effectively, two dual-rank DIMMs on the same module. Only one rank is accessible at a time. The server memory control subsystem selects the proper rank within the DIMM when writing to or reading from the DIMM.

Dual- and quad-rank DIMMs provide the greatest capacity with the existing memory technology. For example, if current DRAM technology supports 8-GB single-rank DIMMs, a dual-rank DIMM would be 16 GB, and a quad-rank DIMM would be 32 GB.

LRDIMMs are labeled as quad-rank DIMMs. There are four ranks of DRAM on the DIMM, but the LRDIMM buffer creates an abstraction that allows the DIMM to appear as a dual-rank DIMM to the system. The LRDIMM buffer isolates the electrical loading of the DRAM from the system to allow for faster operation. This allows higher memory operating speed compared to quad-rank RDIMMs.

DIMM identification

To determine DIMM characteristics, see the label attached to the DIMM and refer to the following illustration and table.

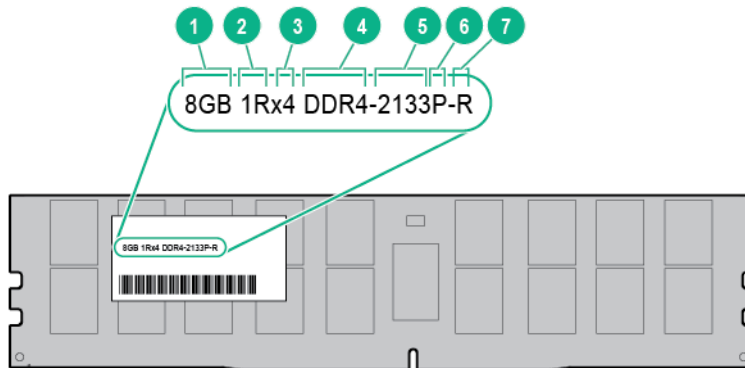

| Item | Description | Definition |
|------|----------------------|--|
| 1 | Capacity | 8 GB 16 GB 32 GB 64 GB |
| 2 | Rank | 1R = Single-rank 2R = Dual-rank 4R = Quad-rank |
| 3 | Data width on DRAM | x4 = 4-bit x8 = 8-bit |
| 4 | Memory generation | DDR4 |
| 5 | Maximum memory speed | 2133 MT/s 2400 MT/s |
| 6 | CAS latency | P=15 T=17 |
| 7 | DIMM type | R = RDIMM (registered) L = LRDIMM (load reduced) |

For more information about product features, specifications, options, configurations, and compatibility, see the product QuickSpecs on the Hewlett Packard Enterprise website (<http://www.hpe.com/info/qs>).

Memory configurations

To optimize server availability, the server supports the following AMP modes:

- Advanced ECC—Provides up to 4-bit error correction. This mode is the default option for this server.
- Online spare memory—Provides protection against failing or degraded DIMMs. Certain memory is reserved as spare, and automatic failover to spare memory occurs when the system detects a DIMM that is degrading. This allows DIMMs that have a higher probability of receiving an uncorrectable memory error (which would result in system downtime) to be removed from operation.
- Mirrored memory—Provides maximum protection against failed DIMMs. Uncorrectable errors in one channel are corrected by the mirror channel.

Advanced Memory Protection options are configured in the BIOS/Platform Configuration (RBSU). If the requested AMP mode is not supported by the installed DIMM configuration, the server boots in Advanced

ECC mode. For more information, see the *HPE UEFI System Utilities User Guide for HPE ProLiant Gen9 Servers* on the Hewlett Packard Enterprise website (<http://www.hpe.com/info/ProLiantUEFI/docs>).

Advanced ECC memory configuration

Advanced ECC memory is the default memory protection mode for this server. Standard ECC can correct single-bit memory errors and detect multi-bit memory errors. When multi-bit errors are detected using Standard ECC, the error is signaled to the server and causes the server to halt.

Advanced ECC protects the server against some multi-bit memory errors. Advanced ECC can correct both single-bit memory errors and 4-bit memory errors if all failed bits are on the same DRAM device on the DIMM.

Advanced ECC provides additional protection over Standard ECC because it is possible to correct certain memory errors that would otherwise be uncorrected and result in a server failure. Using HPE Advanced Memory Error Detection technology, the server provides notification when a DIMM is degrading and has a higher probability of uncorrectable memory error.

Online Spare memory configuration

Online spare memory provides protection against degraded DIMMs by reducing the likelihood of uncorrected memory errors. This protection is available without any operating system support.

Online spare memory protection dedicates one rank of each memory channel for use as spare memory. The remaining ranks are available for OS and application use. If correctable memory errors occur at a rate higher than a specific threshold on any of the non-spare ranks, the server automatically copies the memory contents of the degraded rank to the online spare rank. The server then deactivates the failing rank and automatically switches over to the online spare rank.

Mirrored memory configuration

Mirroring provides protection against uncorrected memory errors that would otherwise result in server downtime. Mirroring is performed at the channel level to one memory channel pair that can be either:

- Channel 1 data being mirrored in channel 2
- Channel 3 data being mirrored in channel 4

If an uncorrectable error is detected in the active memory channel, data is retrieved from the mirror channel. This channel becomes the new active channel, and the system disables the channel with the failed DIMM.

General DIMM slot population guidelines

Observe the following guidelines for all AMP modes:

- Install DIMMs that are optimized for the installed processor ("[Memory-processor compatibility information](#)" on page 49).
To identify the processor type installed in the server, use the BIOS/Platform Configuration (RBSU) of the UEFI System Utilities ("[Identifying the processor type](#)" on page 54).
- Install DIMMs only if the corresponding processor is installed.
- Do not mix LRDIMMs and RDIMMs.
- White DIMM slots denote the first slot of a channel (Ch 1-A, Ch 2-B, Ch 3-C, Ch 4-D).
- When only one processor is installed, install DIMMs in sequential alphabetic order: A, B, C, D.
- When two processors are installed, install the DIMMs in sequential alphabetical order balanced between the two processors: P1-A, P2-A, P1-B, P2-B, P1-C, P2-C, and so forth.

- When single-rank, dual-rank, and quad-rank DIMMs are populated for two DIMMs per channel, always populate the higher number rank DIMM first (starting from the farthest slot). For example, first quad-rank DIMM, then dual-rank DIMM, and then lastly single-rank DIMM.
- DIMMs should be populated starting farthest from the processor on each channel.

For more information about server memory, see the Hewlett Packard Enterprise website (<http://www.hpe.com/info/memory>).

Advanced ECC population guidelines

For Advanced ECC mode configurations, observe the following guidelines:

- Observe the general DIMM slot population guidelines.
- DIMMs may be installed individually.

Online spare population guidelines

For Online Spare memory mode configurations, observe the following guidelines:

- Observe the general DIMM slot population guidelines.
- Each channel must have a valid online spare configuration.
- Each channel can have a different valid online spare configuration.
- Each populated channel must have a spare rank. A single dual-rank DIMM is not a valid configuration.

Mirrored Memory population guidelines

For Mirrored Memory mode configurations, observe the following guidelines:

- Observe the general DIMM slot population guidelines.
- Install DIMMs in either channel 1 and channel 2, or channel 3 and channel 4. Installed DIMMs must be identical in terms of size and organization.
- In multi-processor configurations, each processor must have a valid Mirrored Memory configuration.

Identifying the processor type

The processor type installed in the server is briefly displayed during POST. To view this information and additional processor specifications, do the following:

1. Reboot the server.
The server restarts and the POST screen appears.
2. Press **F9**.
The System Utilities screen appears.
3. Select **System Information | Processor Information**.
The Processor Information screen shows detailed information about the processors installed in the server.
4. Press **Esc** until the main menu is displayed.
5. Select **Reboot the System** to exit the utility and resume the boot process.

Installing a DIMM

1. Power down the server (on page 15).

2. Remove all power:
 - a. Disconnect each power cord from the power source.
 - b. Disconnect each power cord from the server.
3. Do one of the following:
 - o Extend the server from the rack (on page 15).
 - o Remove the server from the rack (on page 18).
4. Remove the access panel (on page 18).
5. Open the DIMM slot latches.
6. Install the DIMM.

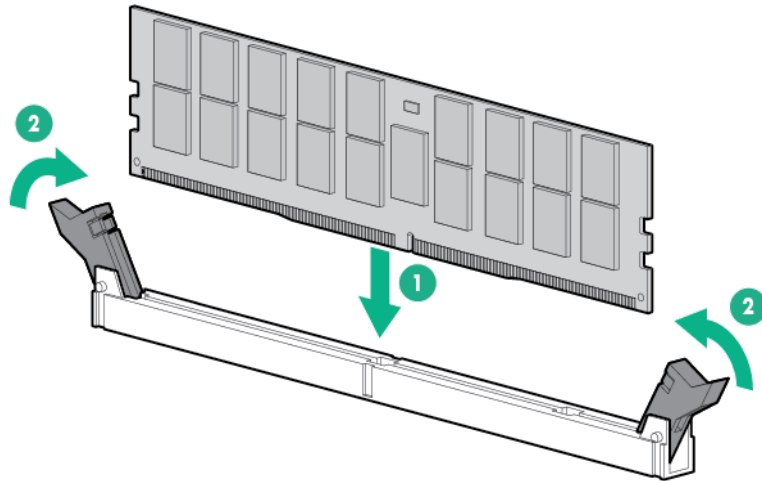

7. Install the access panel (on page 19).
8. Do one of the following:
 - o Slide the server into the rack.
 - o Install the server into the rack.
9. Power up the server (on page 15).

After installing the DIMMs, to configure memory protection mode, use RBSU.

Processor option

The server supports single and dual-processor operations.

Installing a second processor

If you are installing a second Intel Xeon E5-2600 v3 processor in the processor socket 2, follow the procedure in this section.

Upgrading from an existing E5-2600 v3 processor to a E5-2600 v4 processor

This server only supports E5-2600 v4 processors with a TDP specification of 105 W or less. See the Customer Advisory (c04849981) (<http://h20564.www2.hp.com/hpsc/doc/public/display?docId=c04849981>) for the latest information. Read this Customer Advisory in its entirety before selecting a processor upgrade option.

For more information about product features, specifications, options, configurations, and compatibility, see the product QuickSpecs on the Hewlett Packard Enterprise website (<http://www.hp.com/info/qs>).

Processor installation cautions

The server supports single-processor and dual-processor operations.

 **CAUTION:** To avoid damage to the processor and system board, only authorized personnel should attempt to replace or install the processor in this server.

 **CAUTION:** To prevent possible server overheating, always populate each processor socket with a processor socket cover and a processor blank, or a processor and a heatsink.

 **CAUTION:** To prevent possible server malfunction and damage to the equipment, multiprocessor configurations must contain processors with the same part number.

 **IMPORTANT:** If installing a processor with a faster speed, update the system ROM before installing the processor.

 **IMPORTANT:** Processor socket 1 must be populated at all times or the server does not function.

For optimum performance, Hewlett Packard Enterprise recommends:

- Use DIMMs that match the speed of the processor installed in the server. Intel Xeon E5-2600 v4 processors are optimized to work with 2400 MHz DIMMs.
- In a multiprocessor configuration, balance the total capacity of the DIMMs across the processors.

Installing a processor

To install the component:

1. Power down the server (on page 15).
2. Remove all power:
 - a. Disconnect each power cord from the power source.
 - b. Disconnect each power cord from the server.
3. Do one of the following:
 - o Extend the server from the rack (on page 15).
 - o Remove the server from the rack (on page 18).
4. Remove the access panel (on page 18).
5. Remove the second processor blank.

Retain the blank for future use.

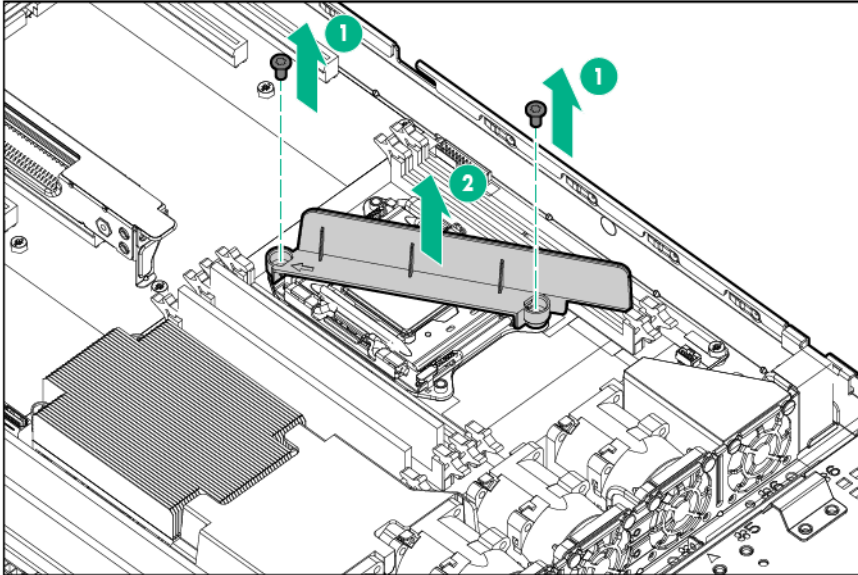

CAUTION: The pins on the processor socket are very fragile. Any damage to them may require replacing the system board.

6. Open each of the processor locking levers in the order indicated in the following illustration, and then open the processor retaining bracket.

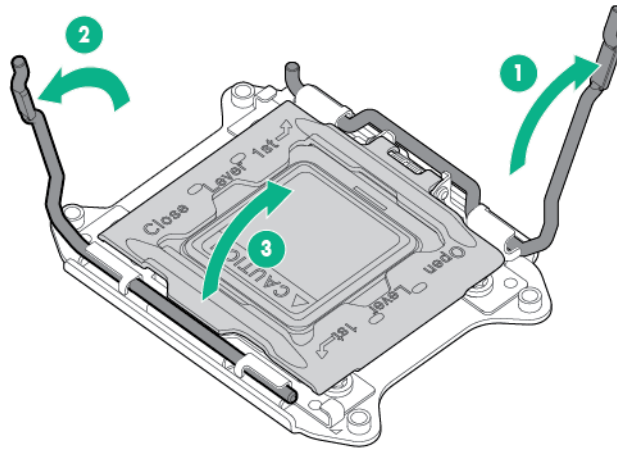

7. Remove the clear processor socket cover. Retain the processor socket cover for future use.

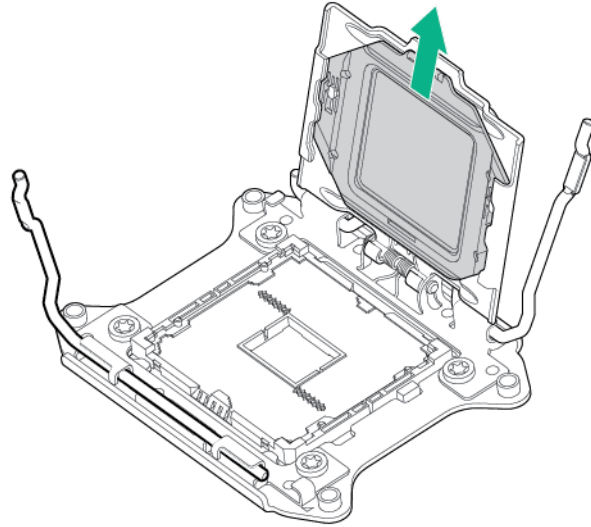

CAUTION: THE PINS ON THE SYSTEM BOARD ARE VERY FRAGILE AND EASILY DAMAGED. To avoid damage to the system board, do not touch the processor or the processor socket contacts.

8. Install the processor. Verify that the processor is fully seated in the processor retaining bracket by visually inspecting the processor installation guides on either side of the processor. **THE PINS ON THE SYSTEM BOARD ARE VERY FRAGILE AND EASILY DAMAGED.**

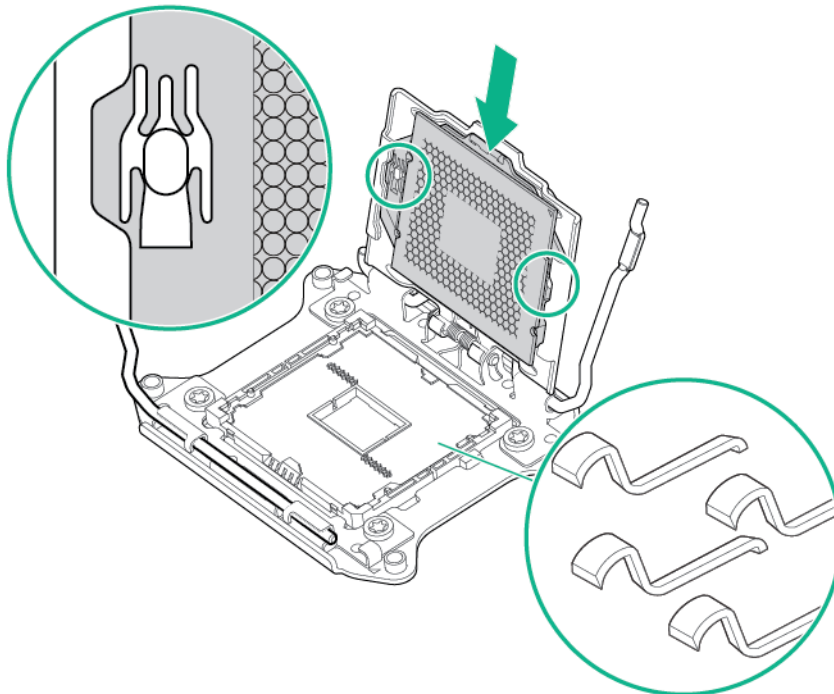

9. Close the processor retaining bracket. When the processor is installed properly inside the processor retaining bracket, the processor retaining bracket clears the flange on the front of the socket.

CAUTION: Do not press down on the processor. Pressing down on the processor may cause damage to the processor socket and the system board. Press only in the area indicated on the processor retaining bracket.

10. Press and hold the processor retaining bracket in place, and then close each processor locking lever. Press only in the area indicated on the processor retaining bracket.

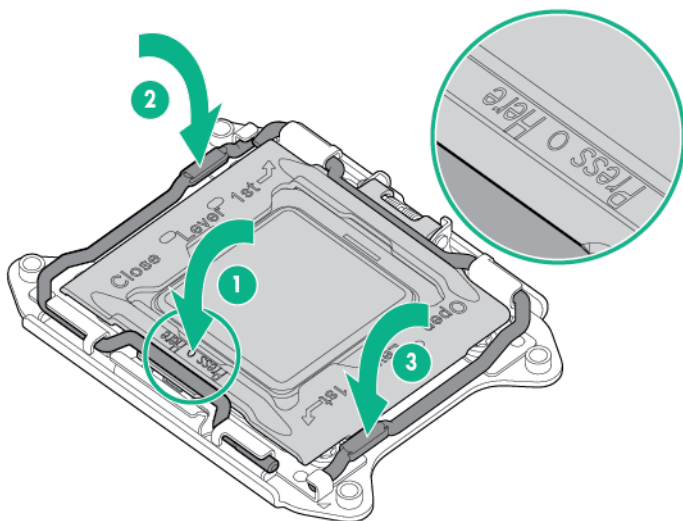

11. Remove the thermal interface protective cover from the heatsink.

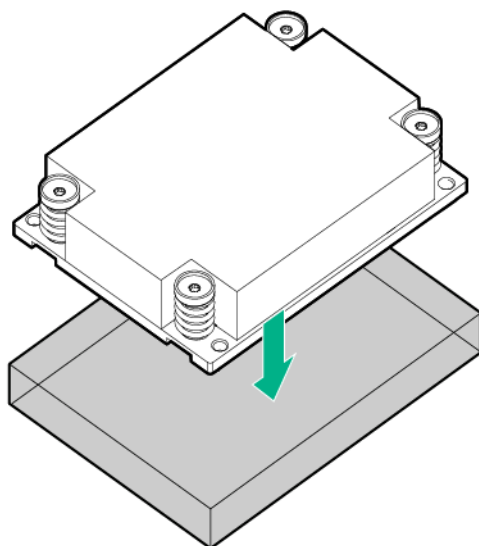

12. Install the heatsink:
 - a. Tighten one pair of diagonally opposite screws halfway, and then tighten the other pair of screws.

- b. Finish the installation by completely tightening the screws in the same sequence.

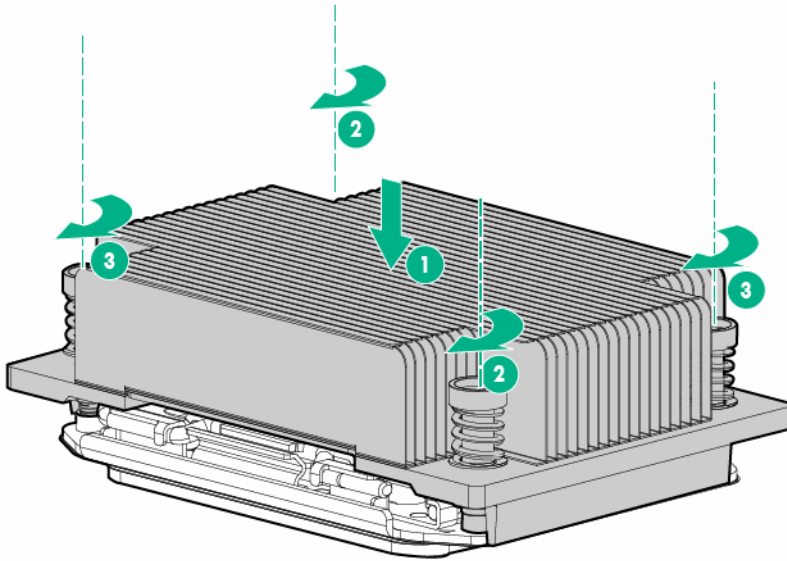

To determine which fan blanks need to be removed to install the additional fans, see "Fan population guidelines."

1. Remove the air baffle (on page 19).
2. Remove the fan blanks.

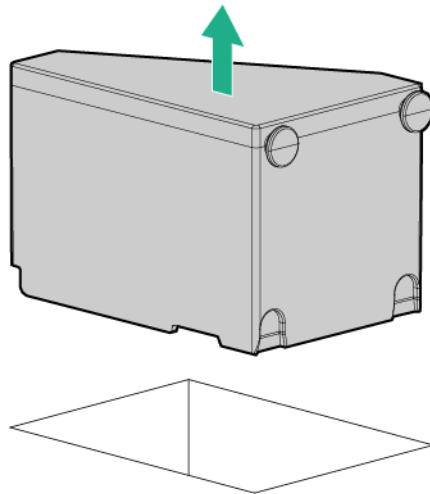

3. Install the additional fans included in the processor option kit.

4. Connect the fan cable to the system board.

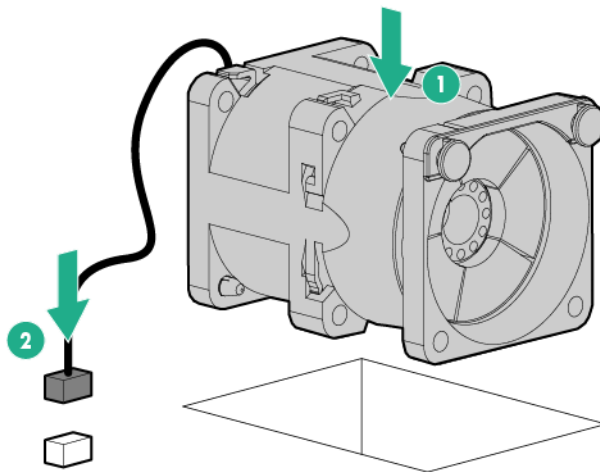

5. Install the air baffle ("Remove the air baffle" on page 19, on page 20).
6. Install the access panel (on page 19).
7. Do one of the following:
 - o Slide the server into the rack.
 - o Install the server into the rack.
8. Power up the server (on page 15).

FlexibleLOM option

For more information about product features, specifications, options, configurations, and compatibility, see the product QuickSpecs on the Hewlett Packard Enterprise website (<http://www.hpe.com/info/gs>).

To install the component:

1. Power down the server (on page 15).
2. Remove all power:
 - a. Disconnect each power cord from the power source.
 - b. Disconnect each power cord from the server.
3. Do one of the following:
 - o Extend the server from the rack (on page 15).
 - o Remove the server from the rack (on page 18).
4. Remove the access panel (on page 18).
5. If necessary, disconnect any internal cables connected to the system board.

6. Remove the PCI riser cage.

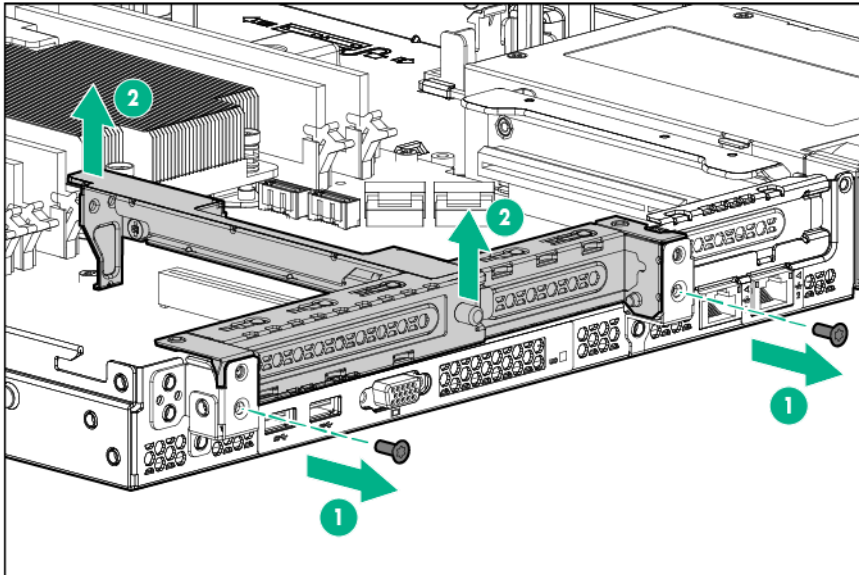

Retain the cage and screws for future use.

7. Remove the blank from the FFlexibleLOM slot of the riser cage.

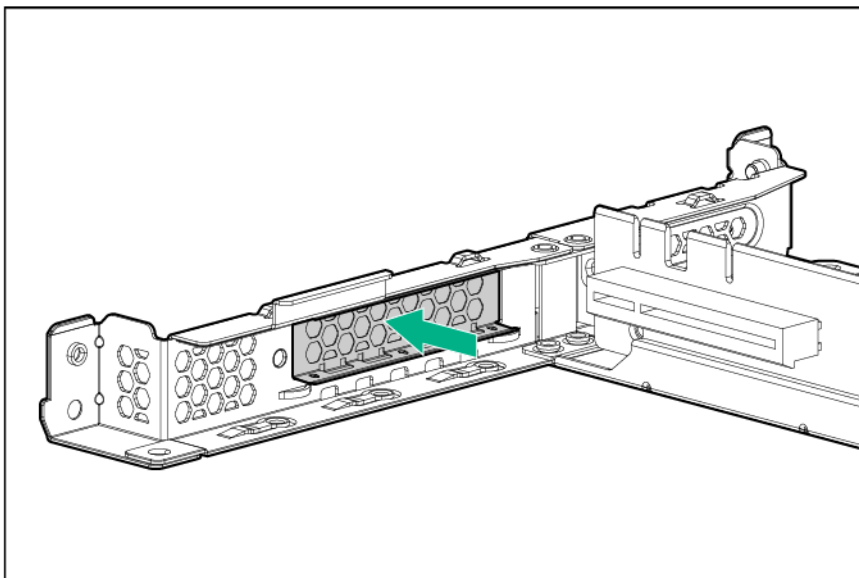

8. Install the component:
 - a. Firmly seat the FlexibleLOM into the slot.

- b. Tighten the T-15 screw to secure the component.

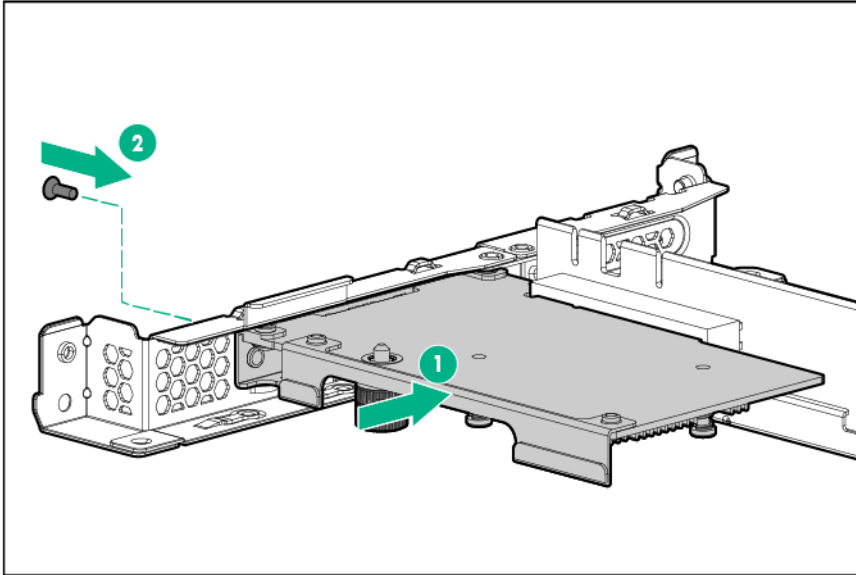

9. Align the PCI riser board with the corresponding connector on the system board, and then press down the riser cage.
10. Tighten the two screws to secure the assembly.

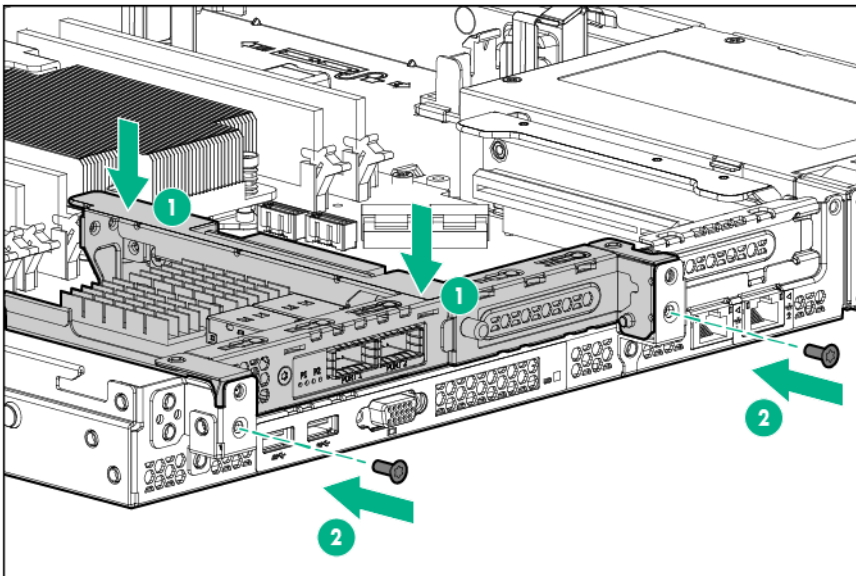

CAUTION: To prevent improper cooling and thermal damage, do not operate the server unless all PCI slots have either an expansion slot cover or an expansion board installed.

11. Install the access panel (on page 19).
12. Do one of the following:
- o Slide the server into the rack.
 - o Install the server into the rack.
13. Power up the server (on page 15).

Full-height half-length riser option

CAUTION: To prevent improper cooling and thermal damage, do not operate the server unless all PCI slots have either an expansion slot cover or an expansion board installed.

For more information about product features, specifications, options, configurations, and compatibility, see the product QuickSpecs on the Hewlett Packard Enterprise website (<http://www.hpe.com/info/qs>).

To install the component:

1. Power down the server (on page 15).
2. Remove all power:
 - a. Disconnect each power cord from the power source.
 - b. Disconnect each power cord from the server.
3. Do one of the following:
 - o Extend the server from the rack (on page 15).
 - o Remove the server from the rack (on page 18).
4. Remove the access panel (on page 18).
5. Remove the PCI blank.

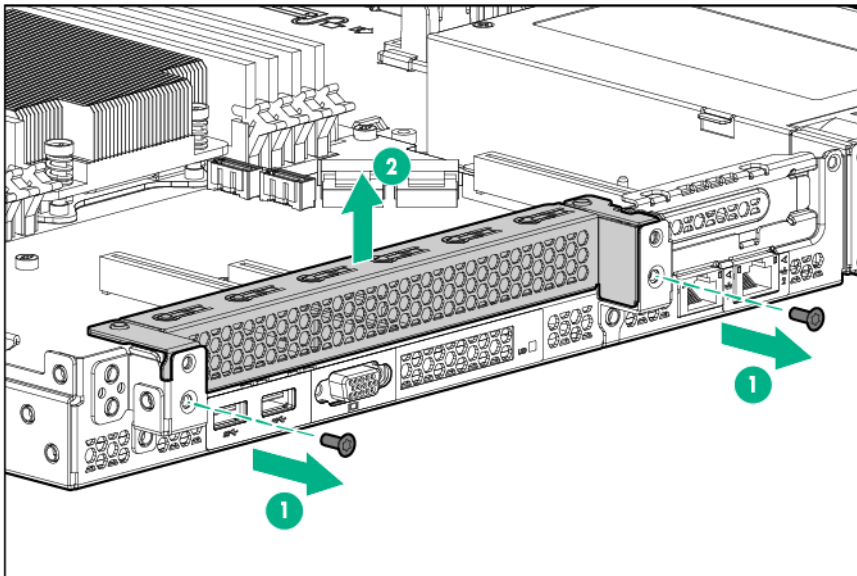

Retain the blank and screws for future use.

6. Remove the slot cover from the riser cage.

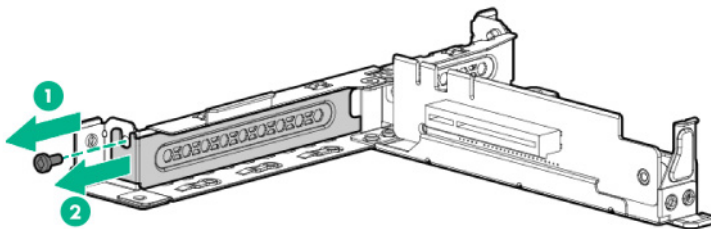

7. Install the expansion board.

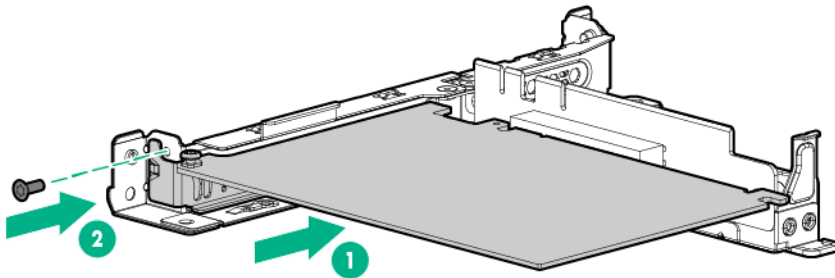

8. Align the PCI riser board with the corresponding connector on the system board, and then press down the riser cage.
9. Tighten the two screws to secure the cage.

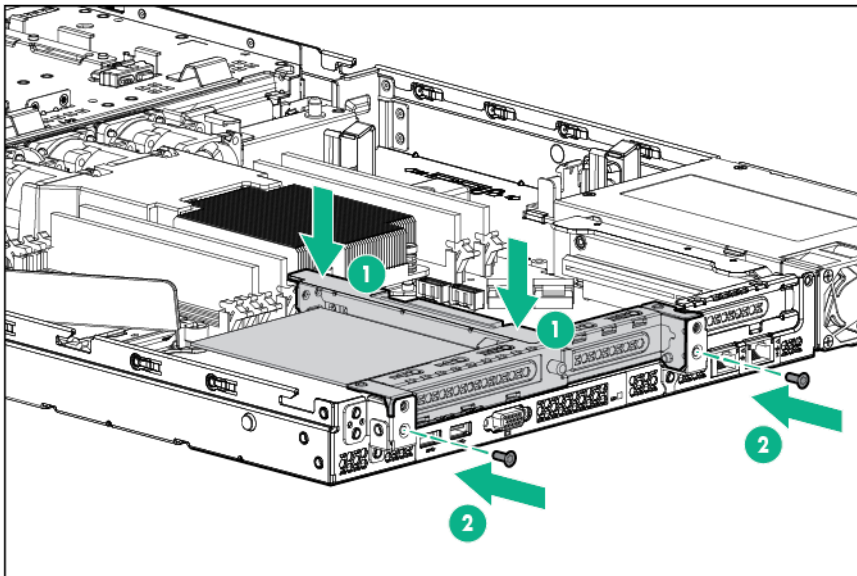

10. Install the access panel (on page 19).
11. Install the server into the rack.
12. Power up the server (on page 15).

Expansion board options

The server has both full-height/half-length and low-profile expansion slots for controller option installation.

For more information about product features, specifications, options, configurations, and compatibility, see the product QuickSpecs on the Hewlett Packard Enterprise website (<http://www.hpe.com/info/qs>).



CAUTION: To prevent damage to the server or expansion boards, power down the server, and disconnect all power cords before removing or installing the PCI riser cage.



CAUTION: To prevent improper cooling and thermal damage, do not operate the server unless all expansion slots have either an expansion slot cover or an expansion board installed.

To install the component:

1. Power down the server (on page 15).
2. Remove all power:
 - a. Disconnect each power cord from the power source.
 - b. Disconnect each power cord from the server.
3. Do one of the following:
 - o Extend the server from the rack (on page 15).
 - o Remove the server from the rack (on page 18).
4. Remove the access panel (on page 18).
5. Remove the secondary PCI riser cage. ("Remove the PCI riser cage" on page 21)
6. Identify the expansion slot compatible with the new option, and then remove the cover opposite that slot.
 - o Slot 1 (If a secondary PCI riser cage is installed, remove the secondary cage before removing the primary riser blank.)

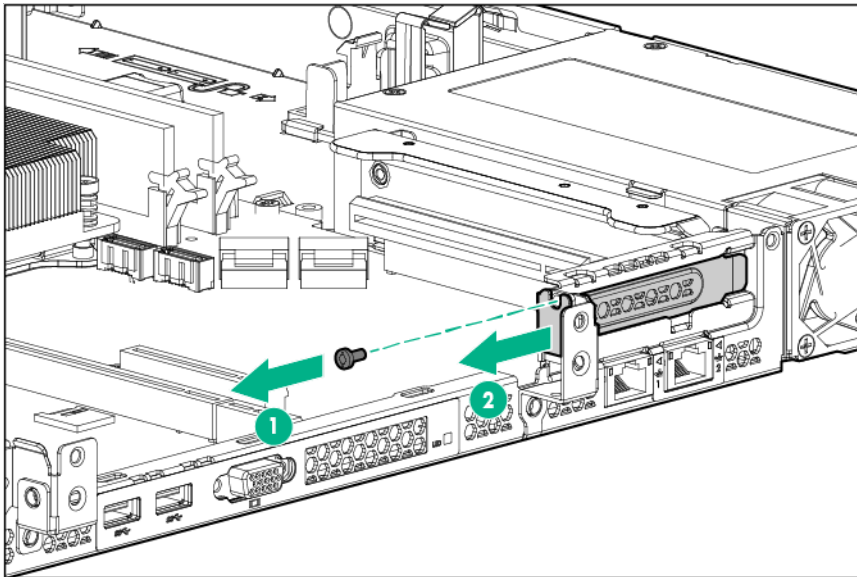

- o Slot 2

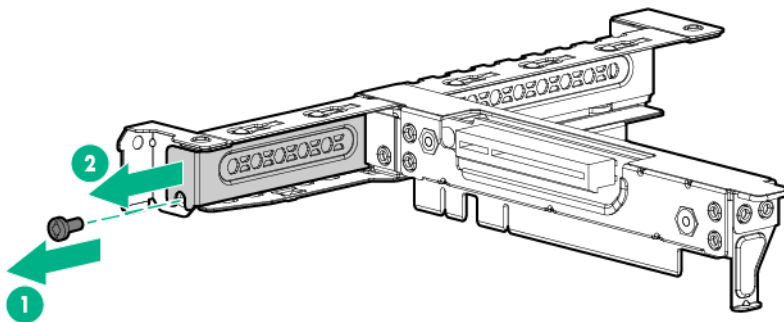

- o Slot 3

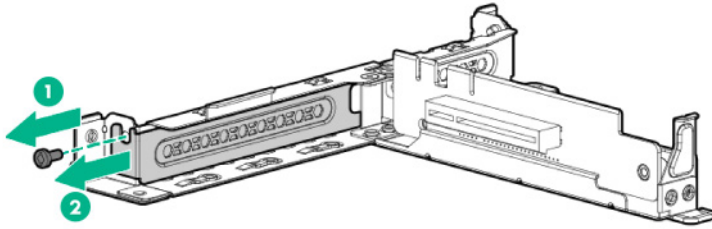

7. Install the expansion board.

- o Slot 1 (If a secondary PCI riser cage is installed, remove the secondary cage before installing the expansion board into slot 1.)

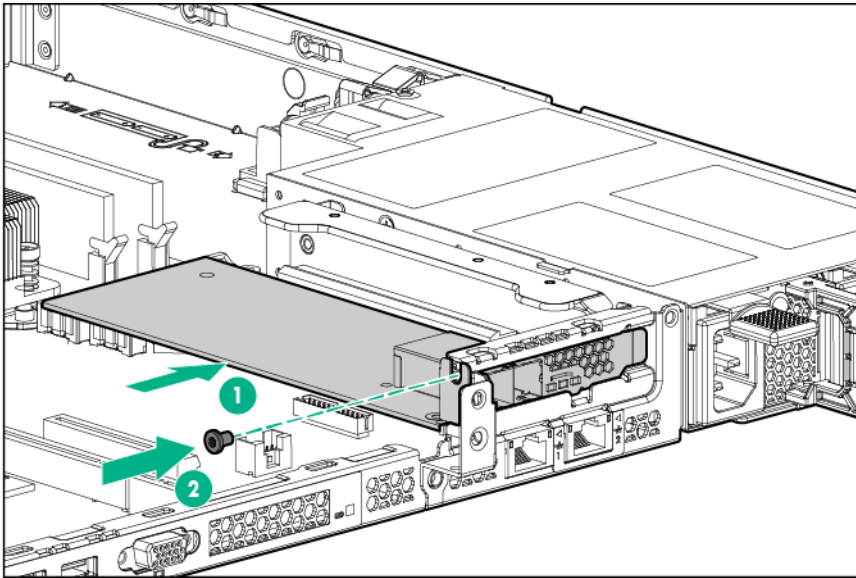

- o Slot 2

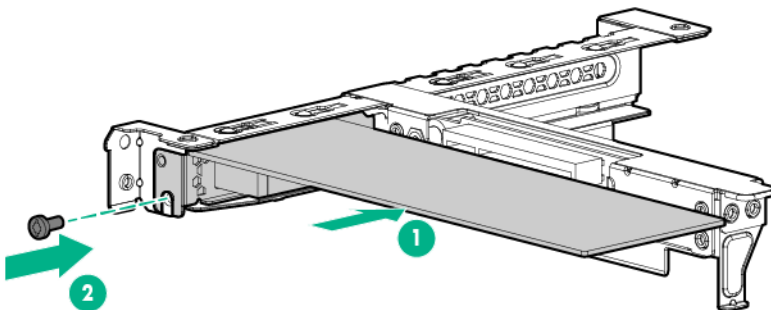

- o Slot 3

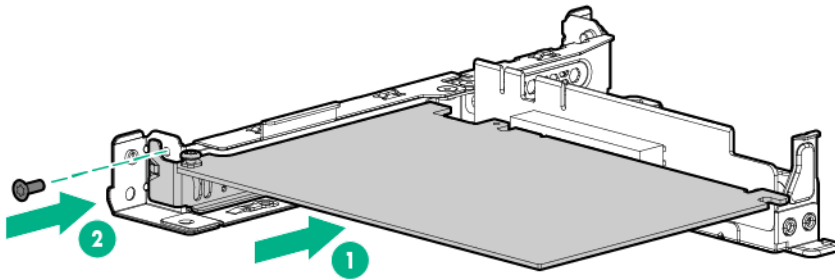

8. Align the PCI riser board with the corresponding connector on the system board, and then press down the riser cage.
9. Tighten the two screws to secure the cage.

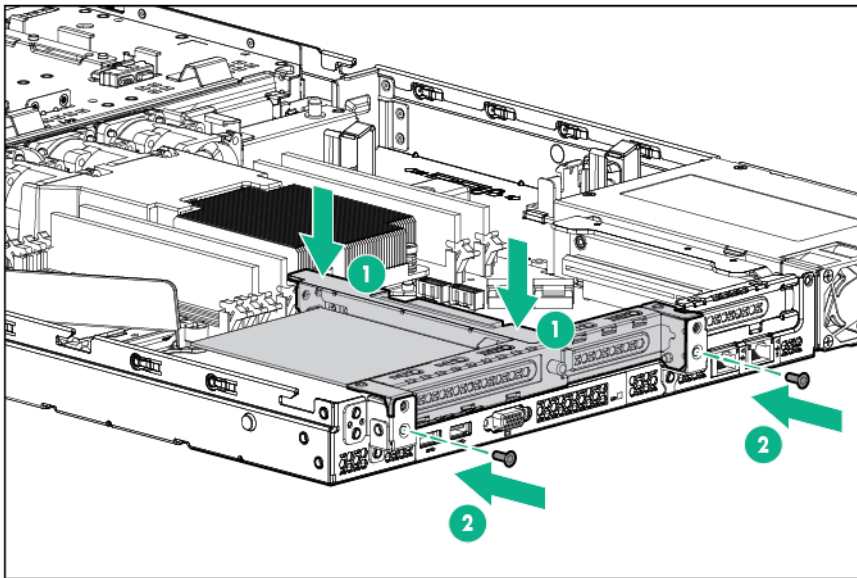

IMPORTANT: The server does not power up if the PCI riser cage is not seated properly.

10. Install the access panel (on page 19).
11. Install the server into the rack.
12. Power up the server (on page 15).

M.2 SSD enablement option

To install the component:

1. Power down the server (on page 15).

2. Remove all power:
 - a. Disconnect each power cord from the power source.
 - b. Disconnect each power cord from the server.
3. Do one of the following:
 - o Extend the server from the rack (on page 15).
 - o Remove the server from the rack (on page 18).
4. Remove the access panel (on page 18).
5. Remove the PCI riser cage (on page 21).
6. Install the SSD module on the M.2 SSD enablement board:
 - a. Insert the SSD module into the SSD slot at a 45 degree angle, and then gently press it down against the M.2 SSD Enablement board.
 - b. Secure the SSD module to the M.2 SSD enablement board with a screw.
 - c. Repeat the process if you are installing a second SSD module.

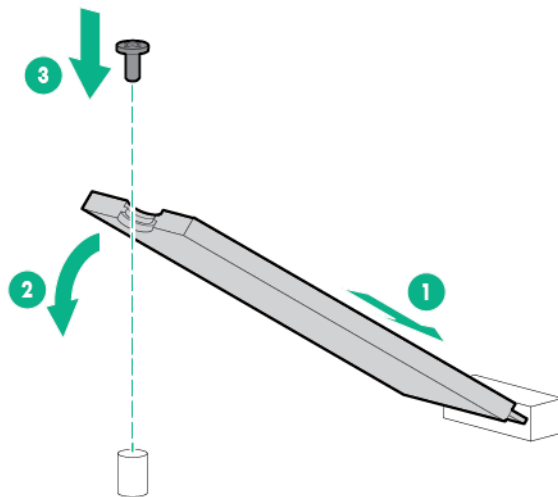

7. Install the M.2 SSD enablement board with SSD modules installed into the PCI riser cage, and then connect the SATA cables to the enablement board.

The M.2 SSD enablement board can only be installed in slot 2 and 3.

The M.2 SSD enablement board must be installed with the separately purchased M.2 SSD SATA right angle cable option. Do not use the vertical cables that come standard with the M.2 SSD enablement option.

- o Slot 2

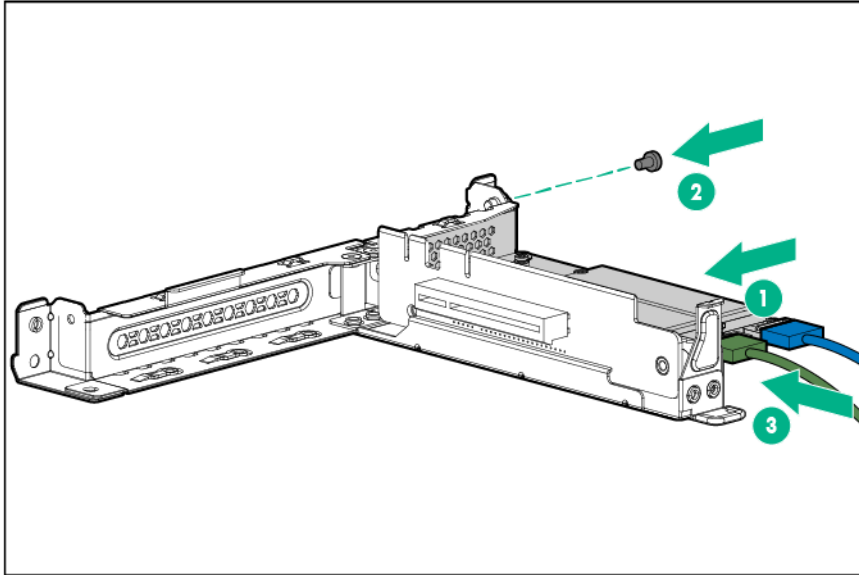

- o Slot 3

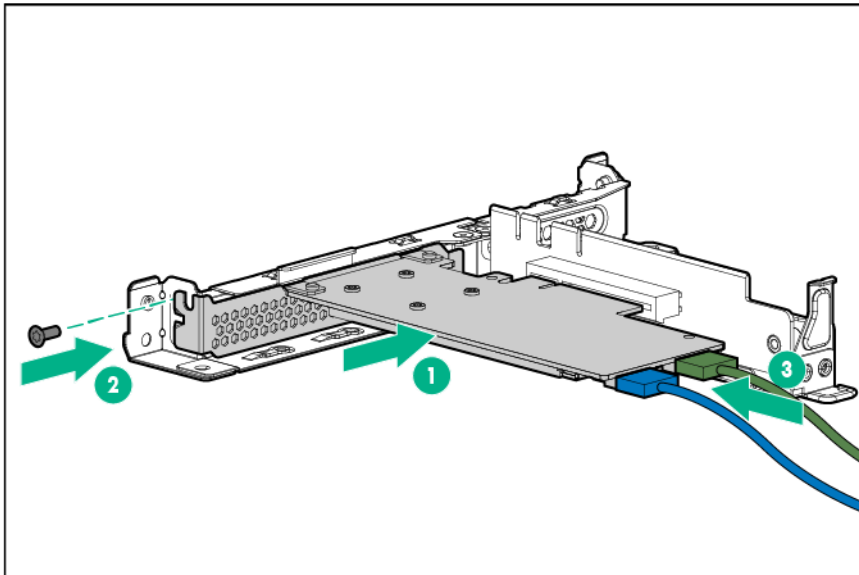

8. Install the PCI riser cage (on page 23).
9. Connect the SATA cables to the SATA connectors on the system board.
For slot 2 and 3 cable routing, see "M.2 SSD cabling (on page 83)."
10. Install the access panel (on page 19).
11. Do one of the following:
 - o Slide the server into the rack.
 - o Install the server into the rack.
12. Power up the server (on page 15).

Dual 8Gb microSD Enterprise Midline USB device

This server supports the installation of the Dual 8Gb microSD Enterprise Midline USB device on the server internal USB connector.

This USB storage device contains a dual-SD card module that supports up to two SD, SDHC, or SDXC storage cards providing data redundancy through a mirrored RAID-1 configuration. This USB storage device connects to an internal USB connector and is configured upon boot.

To locate the internal USB connector, see "System board components (on page 10)." For more information, see the Dual 8Gb microSD EM USB storage device documentation on the Hewlett Packard Enterprise website (<http://www.hpe.com/support/8GBDualMicrosd ug en>).

Redundant power supply option

The redundant power supply option consists of an RPS backplane assembly and two power input modules. Install the RPS option to improve power efficiency and enable power redundancy. Power redundancy requires the installation of two power input modules.

When the RPS backplane and a single power input module are installed in the server, you can install or remove a second power input module without powering down the server.

Power input module and RPS backplane characteristics

- HPE 800 W/900 W Gold AC Power Input Module (744689-B21)
 - This module is compatible with the AC RPS backplane (745813-B21).
 - The module wattage rating changes depending on whether one or two power input modules are installed in the server:
 - One power input module installed (nonredundant): 900 W
 - Two power input modules installed (redundant): 800 W
- HPE 900 W AC/240 V DC Gold Power Input Module (775595-B21)
 - This module is compatible with the AC/240 V DC RPS backplane (814835-B21).
 - The 240 V DC function of this module only applies to server installations based in China.

For more information about the power supply features, specifications, and compatibility, see the Hewlett Packard Enterprise website (<http://www.hpe.com/servers/powersupplies>).

Installing the redundant power supply option

To install the component:

1. Power down the server (on page 15).
2. Access the product rear panel (on page 17).

3. Release the power cord from the strain relief clip.

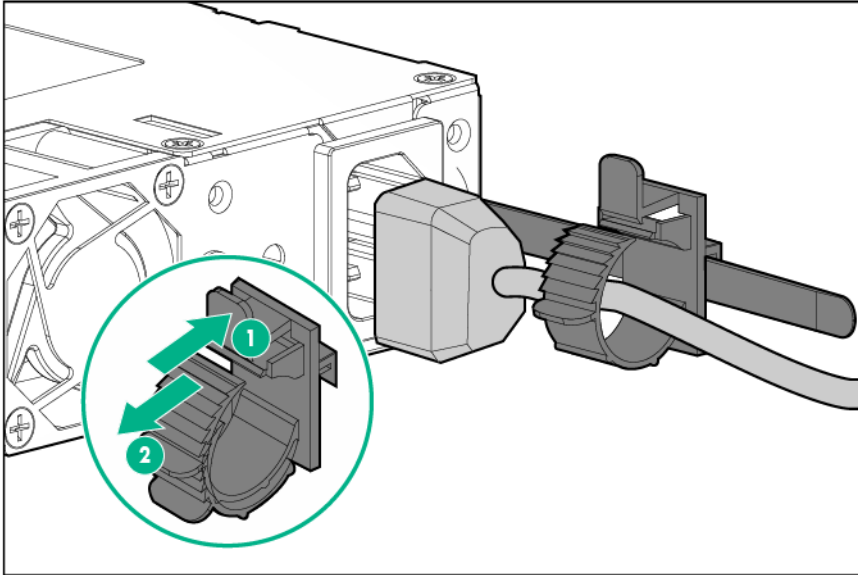

4. Remove all power:
 - a. Disconnect each power cord from the power source.
 - b. Disconnect each power cord from the server.
5. Remove the server from the rack (on page 18).
6. Place the server on a sturdy, level surface.
7. Remove the access panel (on page 18).
8. If installed, remove the secondary PCI riser cage ("[Remove the PCI riser cage](#)" on page 21).
9. Disconnect the non-hot-plug power supply cables.

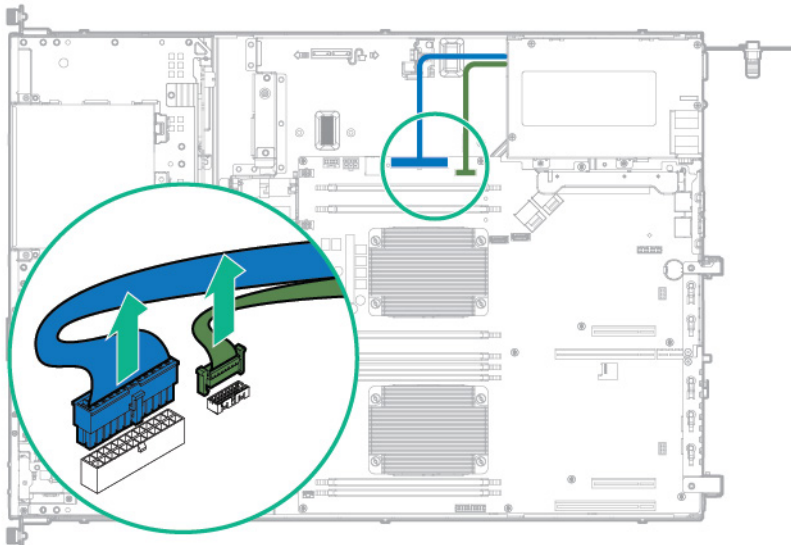

10. Remove the non-hot-plug power supply.

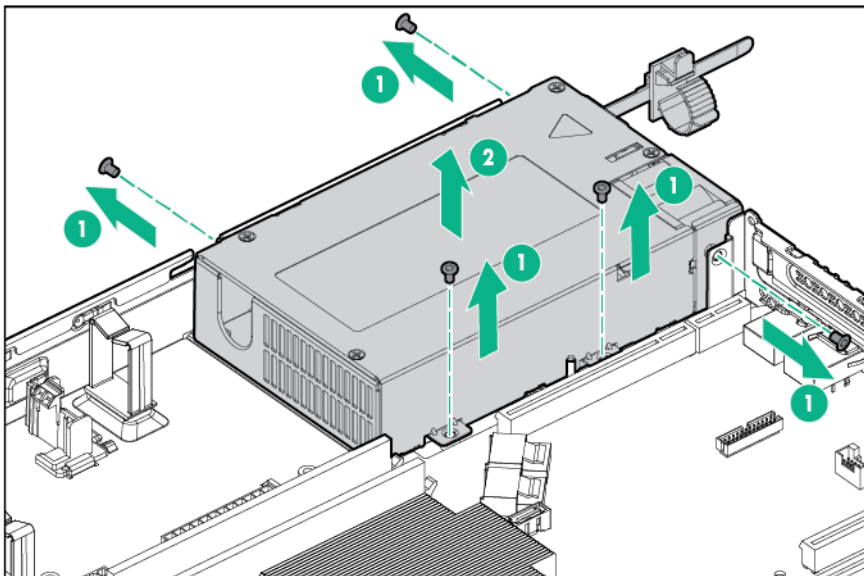

11. Install the RPS backplane assembly in the server.

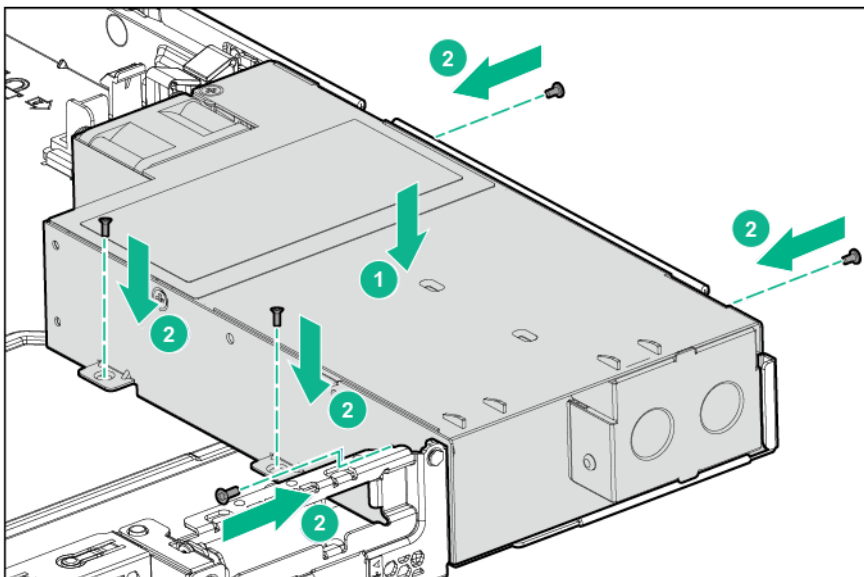

12. Connect the RPS backplane cables to the system board.

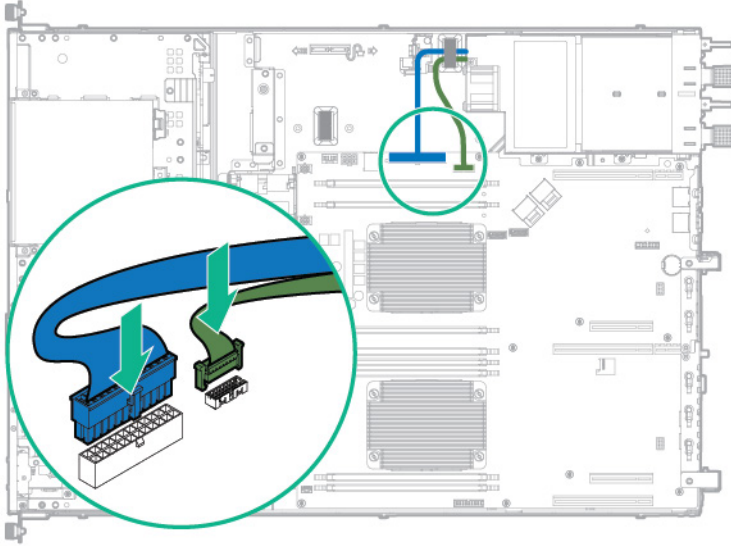

13. Install a hot-plug power input module in power supply bay 1. For the power supply bay locations, see "Rear panel components."

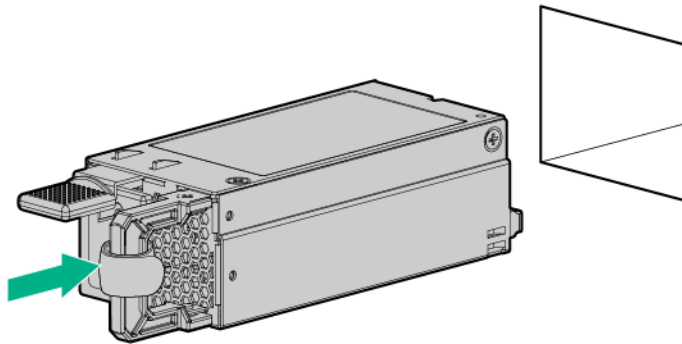

14. If you intend to enable power redundancy in the server, install a second power input module in power supply bay 2:
a. Remove the power supply blank.

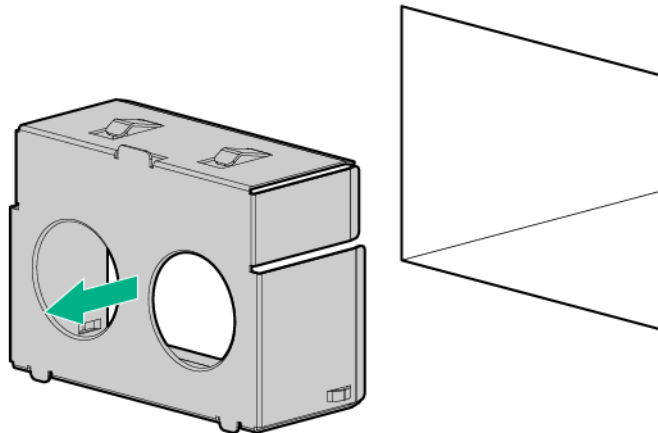

- b. Install a hot-plug power input module in power supply bay 2.
- 15. If removed, install the secondary PCI riser cage.
- 16. Install the access panel (on page 19).
- 17. Install the server into the rack.
- 18. Connect the power cords to the power supplies.
- 19. To prevent accidental power cord disconnection when sliding the server in and out of the rack, secure the power cord in the strain relief strap attached to the power input module handle:
 - a. Unwrap the strain relief strap from the power input module handle.

△ **CAUTION:** Avoid tight bend radii to prevent damaging the internal wires of a power cord or a server cable. Never bend power cords and server cables tight enough to cause a crease in the sheathing.

- b. Bend the plug end of the power cord in the position shown in the following image.

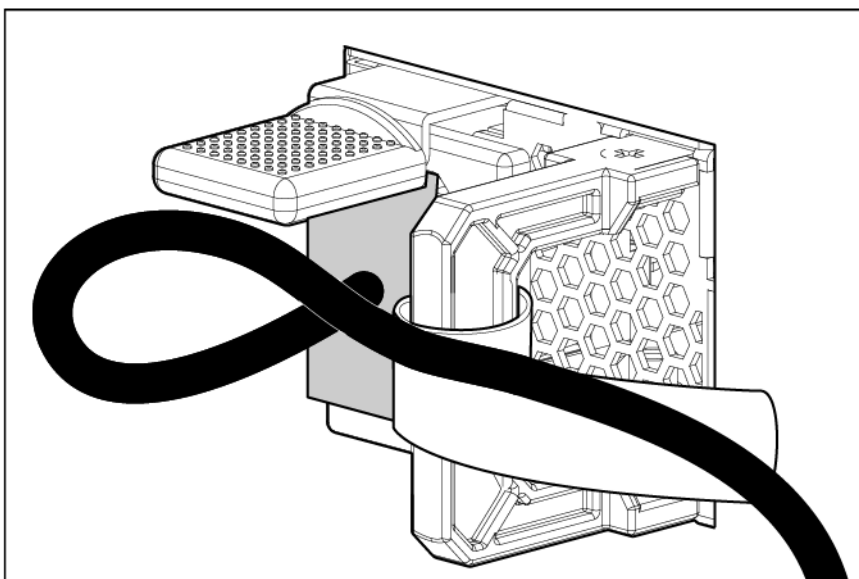

- c. Secure the power cord with the strain relief strap.

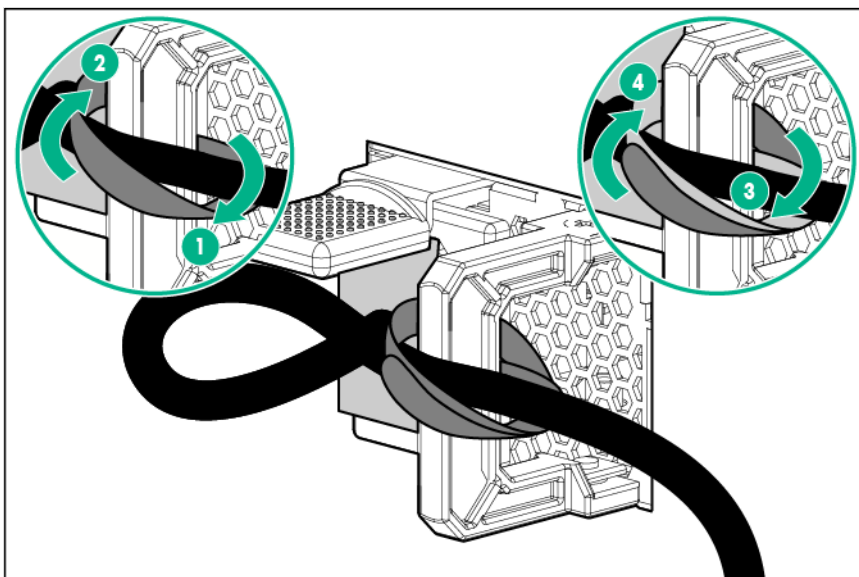

- 20. Connect the power cords to the AC power source.

21. Employ best practices to route and manage the power cords and other cables in the server rear panel.
22. Power up the server (on page 15).

HP Trusted Platform Module option

This server supports both TPM 1.2 and TPM 2.0. However, once the TPM version 1.2 is installed on the system board, it can no longer be upgraded to TPM version 2.0.

For more information about product features, specifications, options, configurations, and compatibility, see the product QuickSpecs on the Hewlett Packard Enterprise website (<http://www.hpe.com/info/qs>).

Use these instructions to install and enable a TPM on a supported server. This procedure includes three sections:

1. Installing the Trusted Platform Module board (on page 76).
2. Retaining the recovery key/password (on page 78).
3. Enabling the Trusted Platform Module (on page 78).

Enabling the TPM requires accessing BIOS/Platform Configuration (RBSU) in UEFI System Utilities ("HPE UEFI System Utilities" on page 94).

TPM installation requires the use of drive encryption technology, such as the Microsoft Windows BitLocker Drive Encryption feature. For more information on BitLocker, see the Microsoft website (<http://www.microsoft.com>).



CAUTION: Always observe the guidelines in this document. Failure to follow these guidelines can cause hardware damage or halt data access.

When installing or replacing a TPM, observe the following guidelines:

- Do not remove an installed TPM. Once installed, the TPM becomes a permanent part of the system board.
- When installing or replacing hardware, Hewlett Packard Enterprise service providers cannot enable the TPM or the encryption technology. For security reasons, only the customer can enable these features.
- When returning a system board for service replacement, do not remove the TPM from the system board. When requested, Hewlett Packard Enterprise Service provides a TPM with the spare system board.
- Any attempt to remove an installed TPM from the system board breaks or disfigures the TPM security rivet. Upon locating a broken or disfigured rivet on an installed TPM, administrators should consider the system compromised and take appropriate measures to ensure the integrity of the system data.
- When using BitLocker, always retain the recovery key/password. The recovery key/password is required to enter Recovery Mode after BitLocker detects a possible compromise of system integrity.
- Hewlett Packard Enterprise is not liable for blocked data access caused by improper TPM use. For operating instructions, see the encryption technology feature documentation provided by the operating system.

Installing the Trusted Platform Module board



WARNING: To reduce the risk of personal injury, electric shock, or damage to the equipment, remove the power cord to remove power from the server. The front panel Power On/Standby button does not completely shut off system power. Portions of the power supply and some internal circuitry remain active until AC power is removed.

⚠ WARNING: To reduce the risk of personal injury from hot surfaces, allow the drives and the internal system components to cool before touching them.

To install the component:

1. Power down the server (on page 15).
2. Remove all power:
 - a. Disconnect each power cord from the power source.
 - b. Disconnect each power cord from the server.
3. Do one of the following:
 - o Extend the server from the rack (on page 15).
 - o Remove the server from the rack (on page 18).
4. Remove the access panel (on page 18).
5. Remove the PCI riser cage (on page 21).
6. If an expansion board is installed in slot 3, remove the board before installing the TPM.

⚠ CAUTION: Any attempt to remove an installed TPM from the system board breaks or disfigures the TPM security rivet. Upon locating a broken or disfigured rivet on an installed TPM, administrators should consider the system compromised and take appropriate measures to ensure the integrity of the system data.

7. Install the TPM board. Press down on the connector to seat the board ("[System board components](#)" on page 10).

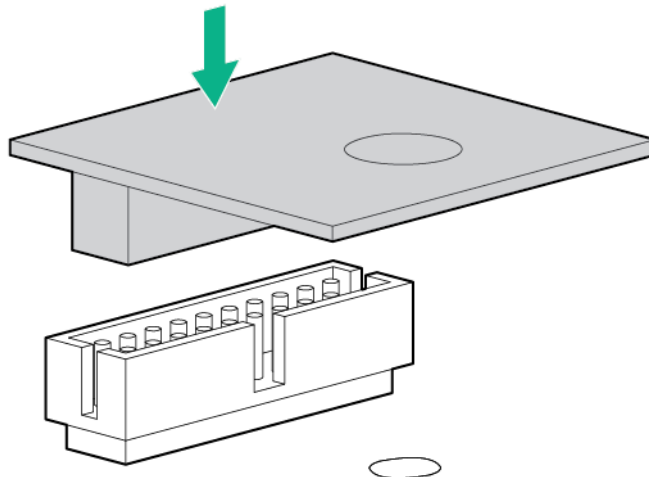

8. Install the TPM security rivet by pressing the rivet firmly into the system board.

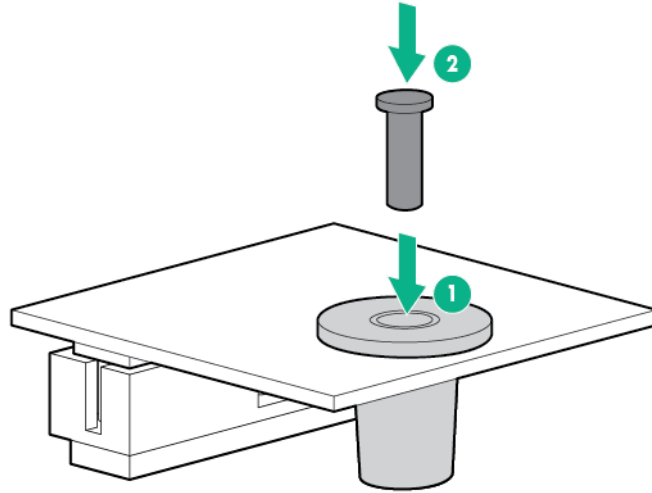

9. Install the PCI riser cage (on page 23).
10. Install the access panel (on page 19).
11. Install the server into the rack.
12. Power up the server (on page 15).

Retaining the recovery key/password

The recovery key/password is generated during BitLocker setup, and can be saved and printed after BitLocker is enabled. When using BitLocker, always retain the recovery key/password. The recovery key/password is required to enter Recovery Mode after BitLocker detects a possible compromise of system integrity.

To help ensure maximum security, observe the following guidelines when retaining the recovery key/password:

- Always store the recovery key/password in multiple locations.
- Always store copies of the recovery key/password away from the server.
- Do not save the recovery key/password on the encrypted hard drive.

Enabling the Trusted Platform Module

1. During the server startup sequence, press the **F9** key to access System Utilities.
2. From the System Utilities screen, select **System Configuration > BIOS/Platform Configuration (RBSU) > Server Security**.
3. Select **Trusted Platform Module Options** and press the **Enter** key.
4. Select **Enabled** to enable the TPM and BIOS secure startup. The TPM is fully functional in this mode.
5. Press the **F10** key to save your selection.
6. When prompted to save the change in System Utilities, press the **Y** key.
7. Press the **ESC** key to exit System Utilities. Then, press the **Enter** key when prompted to reboot the server.

The server then reboots a second time without user input. During this reboot, the TPM setting becomes effective.

You can now enable TPM functionality in the OS, such as Microsoft Windows BitLocker or measured boot.



CAUTION: When a TPM is installed and enabled on the server, data access is locked if you fail to follow the proper procedures for updating the system or option firmware, replacing the system board, replacing a hard drive, or modifying OS application TPM settings.

For more information on firmware updates and hardware procedures, see the *HP Trusted Platform Module Best Practices White Paper* on the Hewlett Packard Enterprise Support Center website (<http://www.hpe.com/support/hpesc>).

For more information on adjusting TPM usage in BitLocker, see the Microsoft website (<http://technet.microsoft.com/en-us/library/cc732774.aspx>).

Cabling

Cabling overview

This section provides guidelines that help you make informed decisions about cabling the server and hardware options to optimize performance.

For information on cabling peripheral components, refer to the white paper on high-density deployment at the Hewlett Packard Enterprise website (<http://www.hpe.com/info/servers>).

CAUTION: When routing cables, always be sure that the cables are not in a position where they can be pinched or crimped.

Storage cabling

Depending on the controller option installed, the actual storage controller connectors might look different from what is shown in this section.

Four-bay LFF non-hot-plug drive cabling

- Four-bay LFF non-hot-plug drive backplane connected to the system board

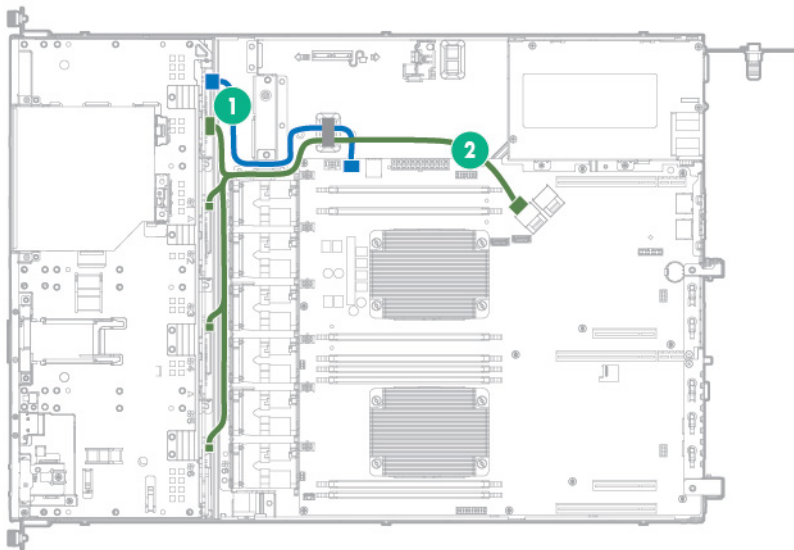

| Item | Description |
|------|-------------------|
| 1 | Drive power cable |
| 2 | Mini-SAS cable |

- Four-bay LFF non-hot-plug drive backplane connected to the H240 Host Bus Adapter

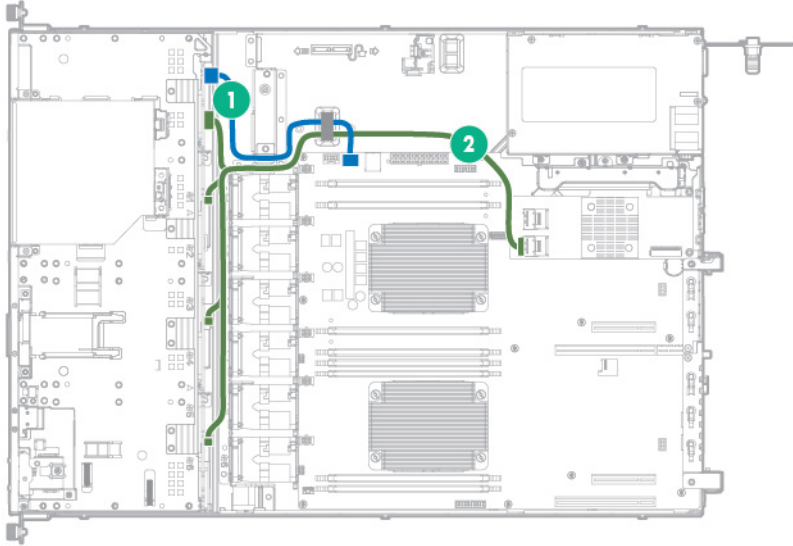

| Item | Description |
|------|-------------------|
| 1 | Drive power cable |
| 2 | Mini-SAS cable |

Four-bay LFF hot-plug drive cabling

- Four-bay LFF drive backplane connected to the system board

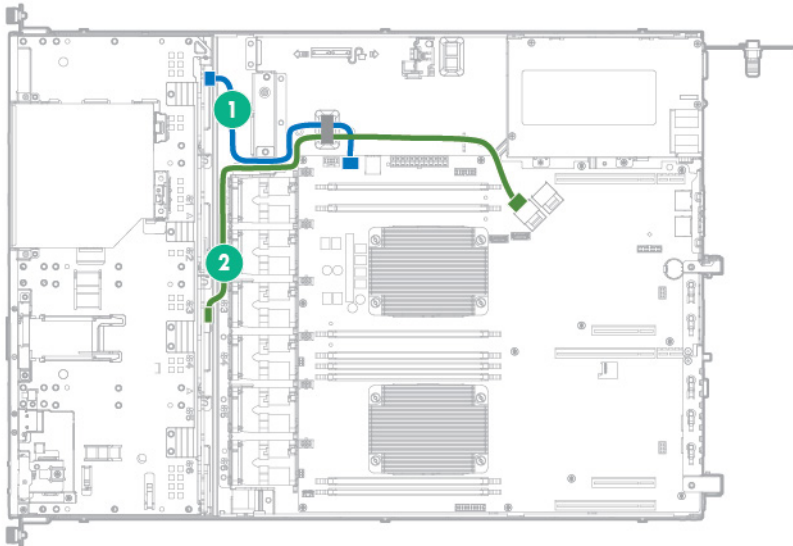

| Item | Description |
|------|-------------------|
| 1 | Drive power cable |
| 2 | Mini-SAS cable |

- Four-bay LFF drive backplane connected to a P440 controller in the low-profile expansion slot 1

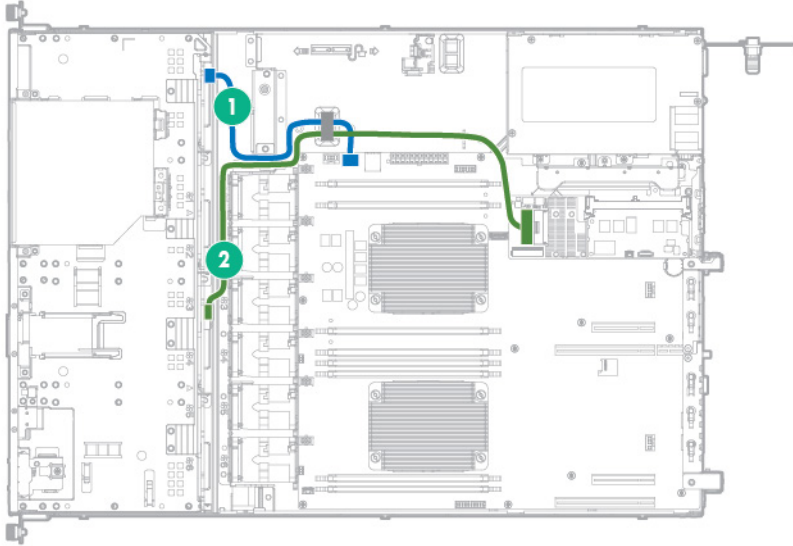

| Item | Description |
|------|-------------------|
| 1 | Drive power cable |
| 2 | Mini-SAS cable |

- Four-bay LFF drive backplane connected to a H240 adapter in the low-profile expansion slot 1

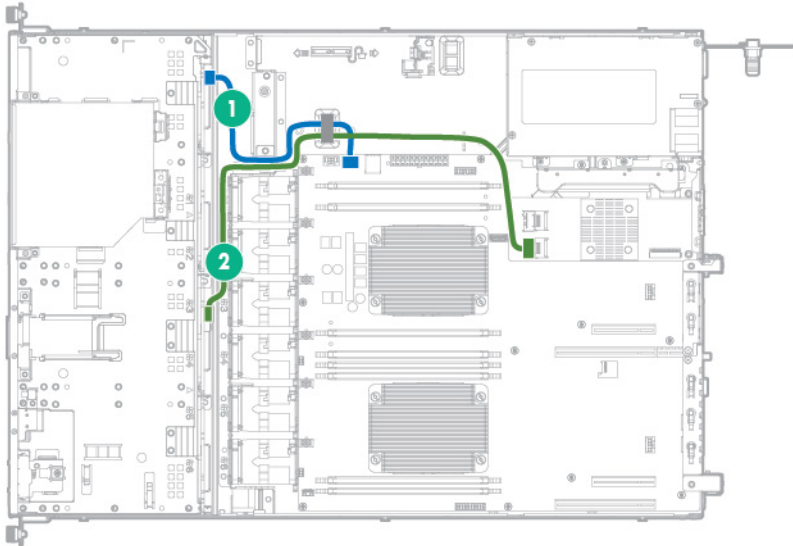

| Item | Description |
|------|-------------------|
| 1 | Drive power cable |
| 2 | Mini-SAS cable |

M.2 SSD cabling

- Slot 2 cable routing (2 ports supported when slot 1 is unoccupied)

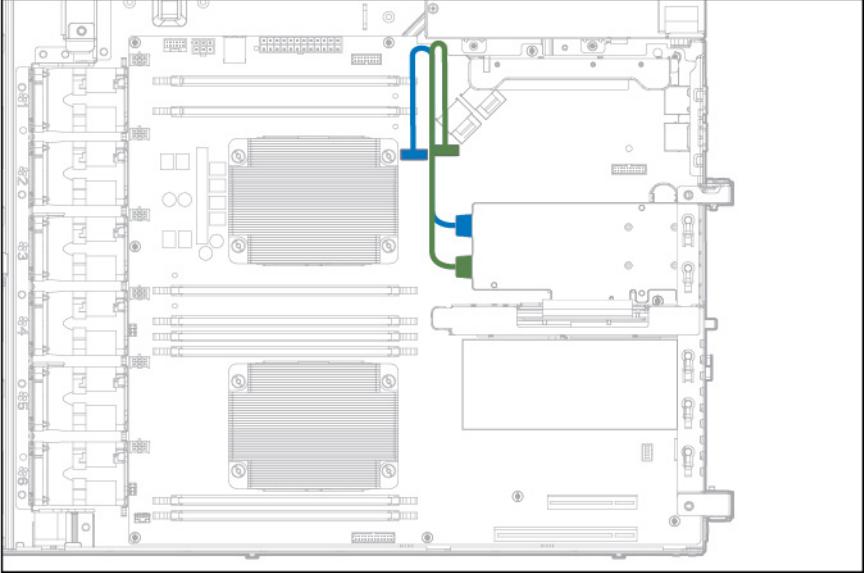

- Slot 2 cable routing (1 port supported when slot 1 is occupied)

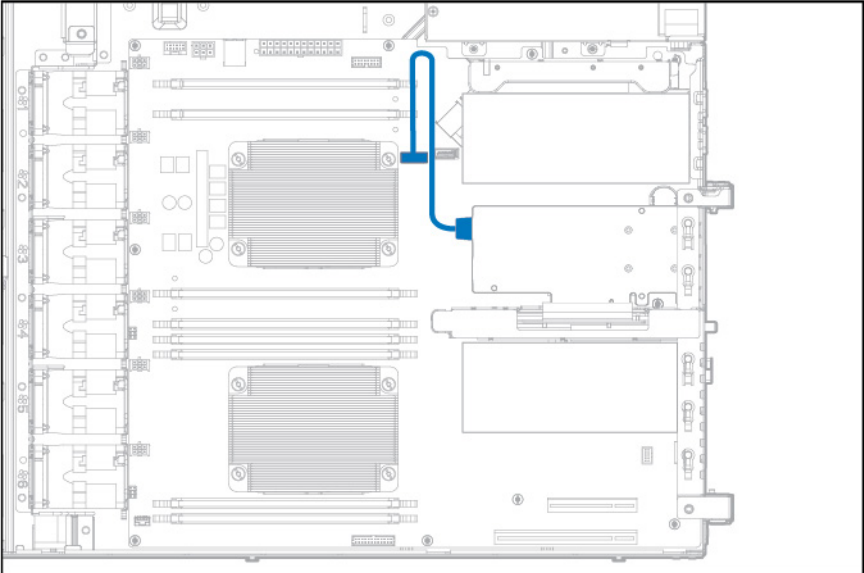

- Slot 3 cable routing (2 ports supported when slot 1 is unoccupied)

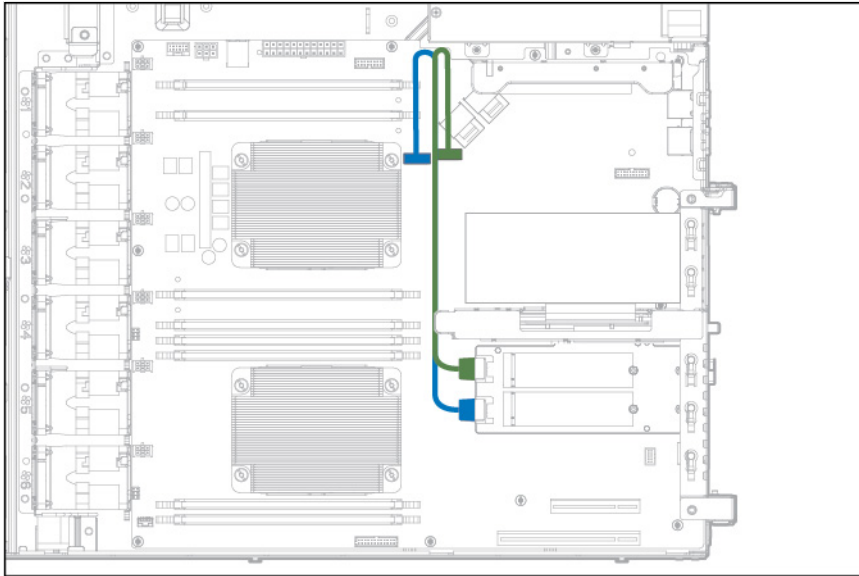

- Slot 3 cable routing (1 port supported when slot 1 is occupied)

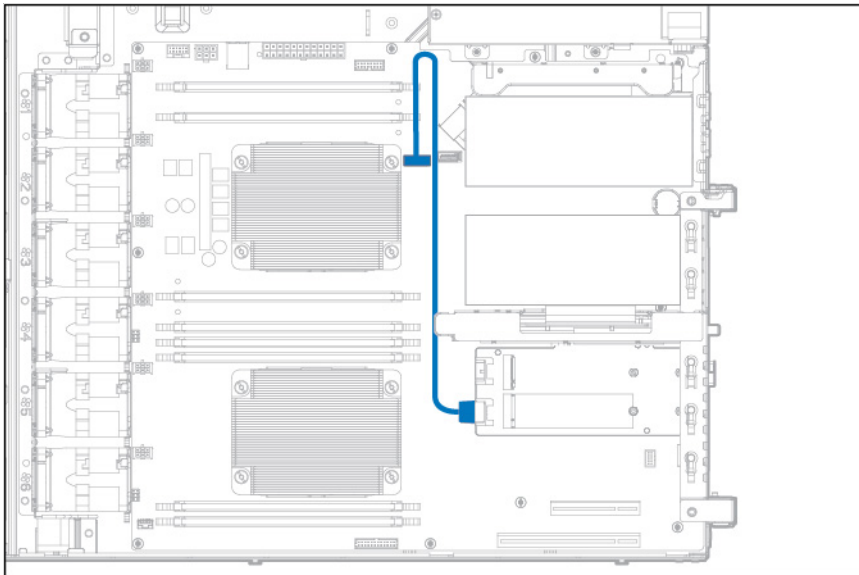

- Slot 2 cable routing with FlexibleLOM riser (2 ports supported when slot 1 is unoccupied)

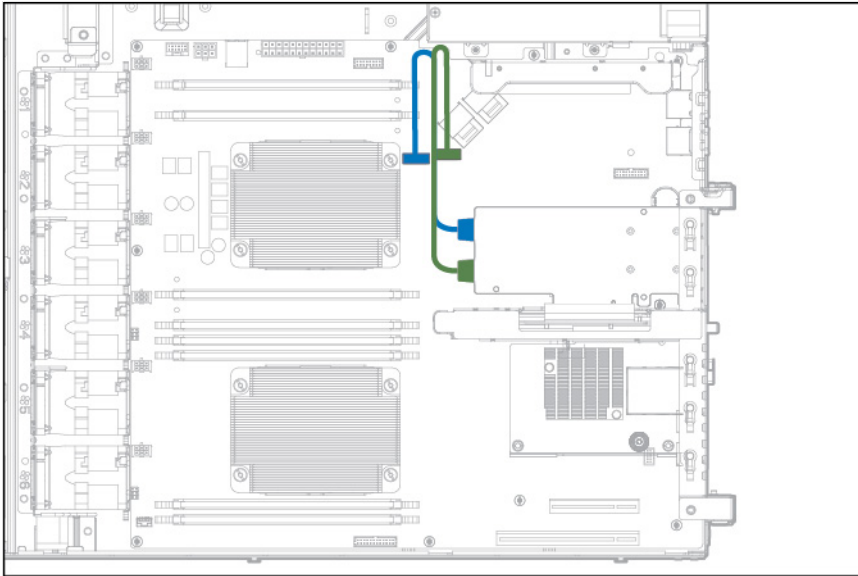

- Slot 2 cable routing with FlexibleLOM riser (1 port supported when slot 1 is occupied)

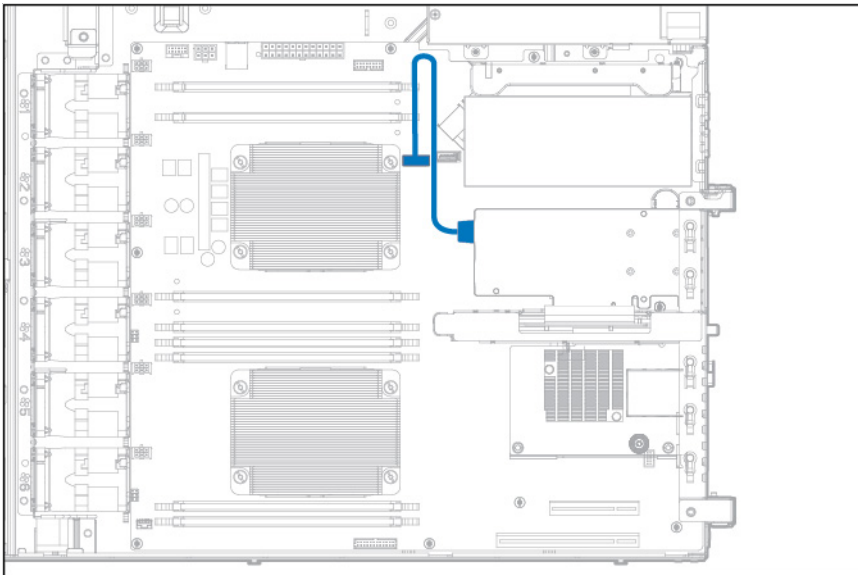

FBWC cabling

The FBWC solution is a separately purchased option. This server only supports FBWC module installation when a Smart Array P-Series controller is installed.

Depending on the controller option installed, the actual storage controller connectors might look different from what is shown in this section.

- FBWC module slot 1 cabling

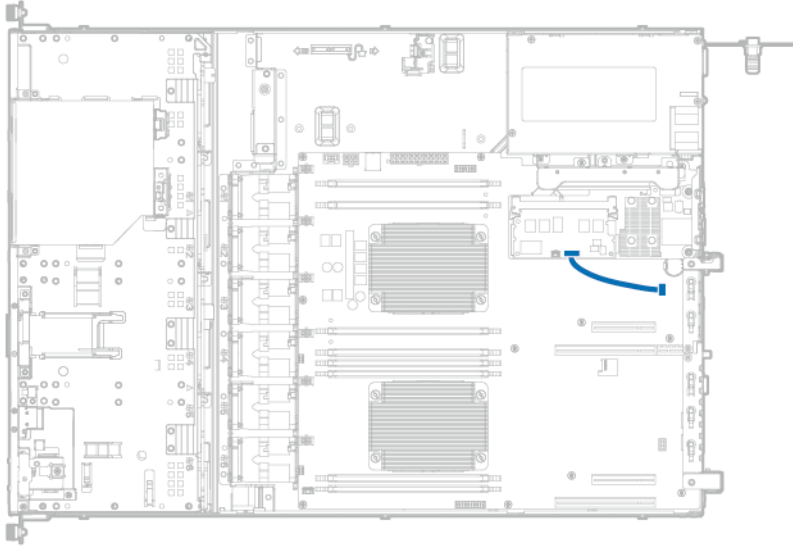

- FBWC module slot 2 cabling

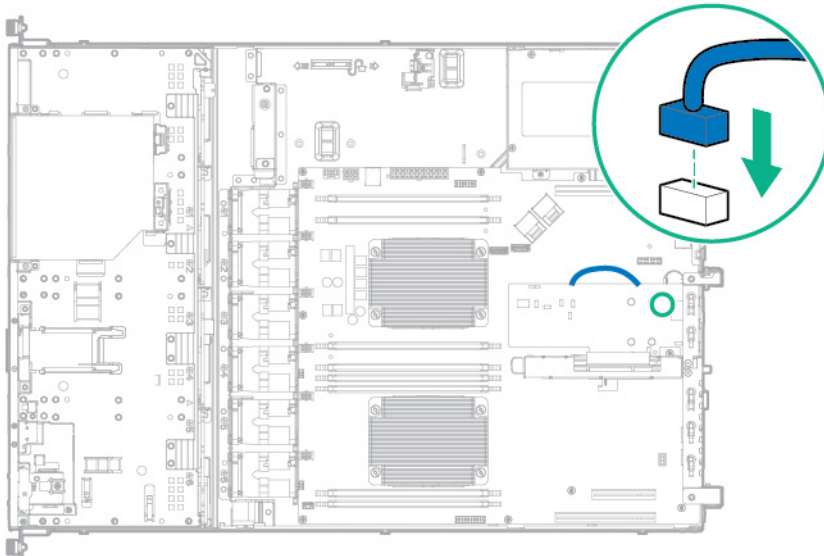

- FBWC module slot 3 cabling

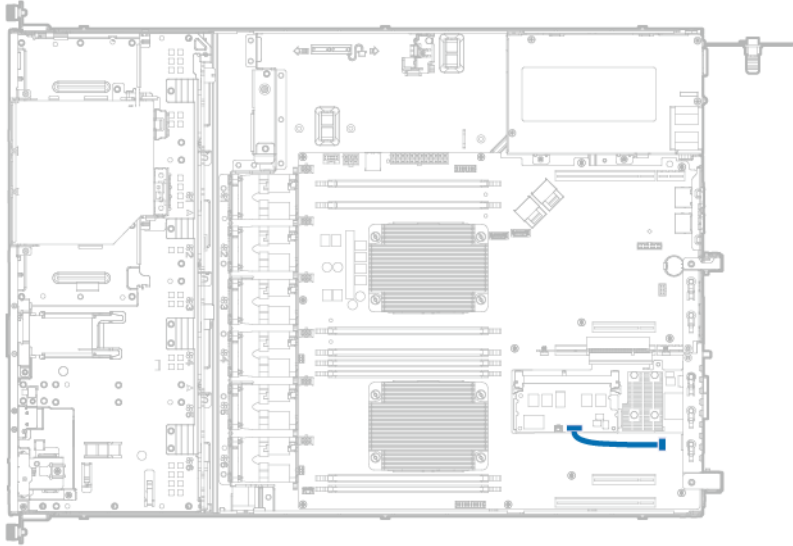

Smart Storage battery cabling

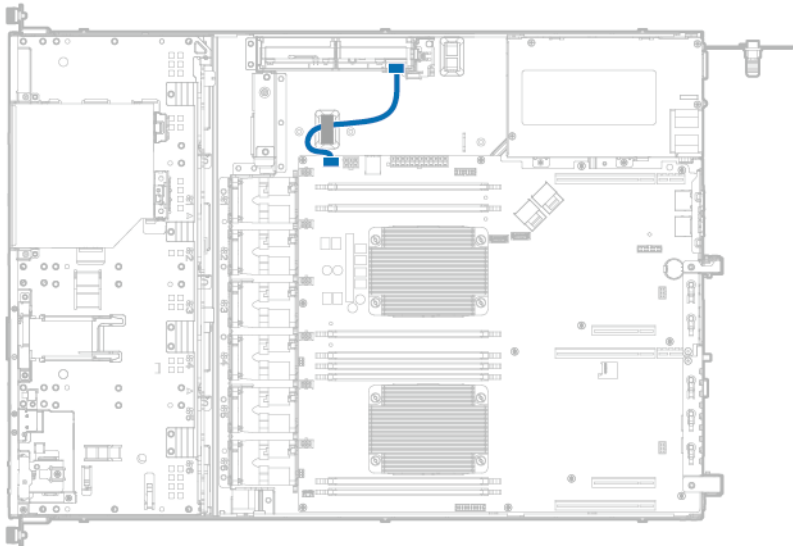

Power supply cabling

- HPE 550 W non-hot-plug power supply cabling

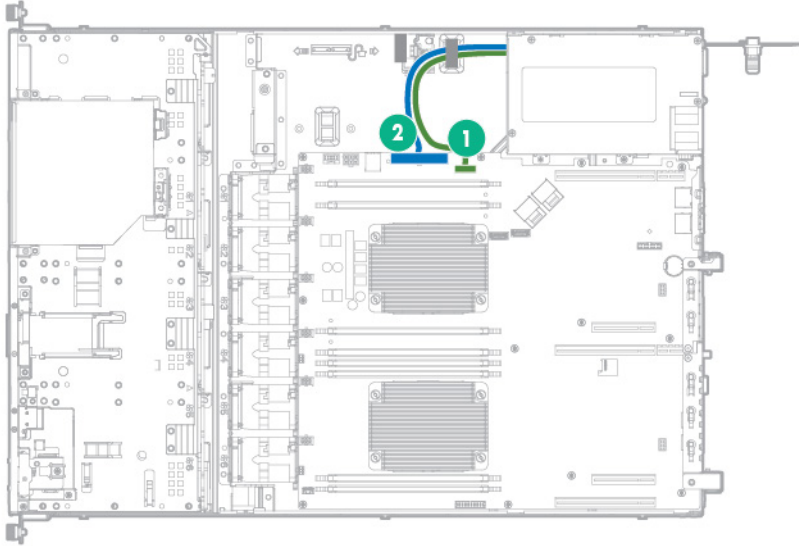

| Item | Description |
|------|---|
| 1 | 16-pin power supply sideband signal cable |
| 2 | 24-pin power supply cable |

- HPE Redundant Power Supply cabling

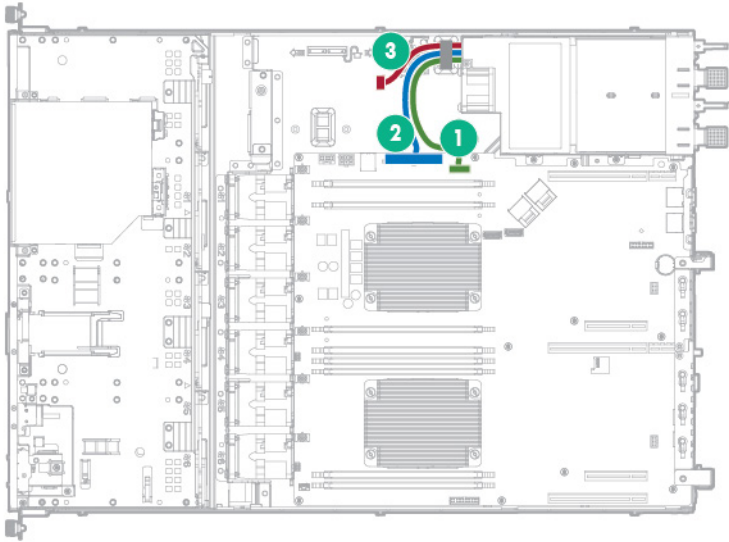

| Item | Description |
|------|---|
| 1 | 16-pin power supply sideband signal cable |
| 2 | 24-pin power supply cable |
| 3 | Reserved |

Optical drive cabling

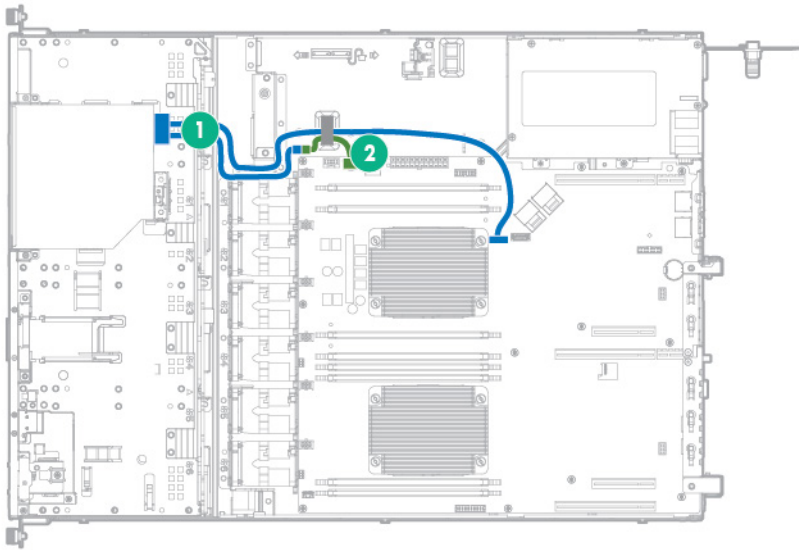

| Item | Description |
|------|---------------------|
| 1 | Optical drive cable |
| 2 | Drive power cable |

Front I/O cabling

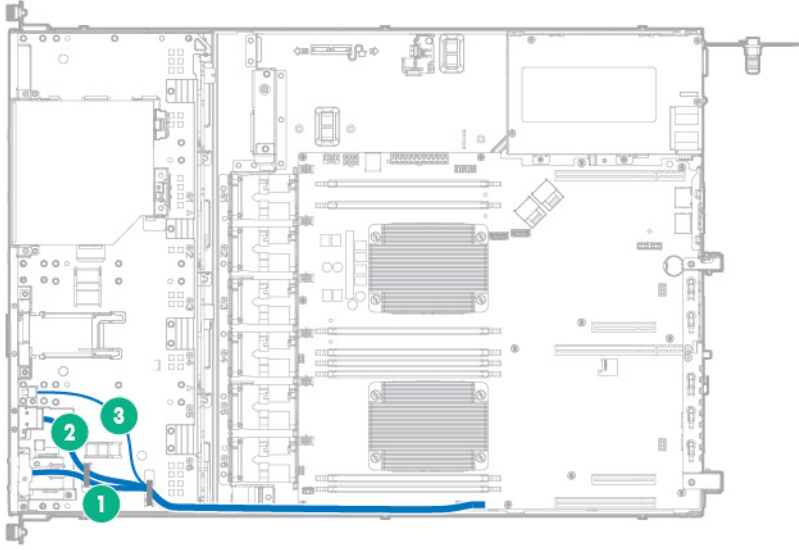

| Item | Description |
|------|----------------------------------|
| 1 | Front I/O cable |
| 2 | USB 2.0 connector cable |
| 3 | Ambient temperature sensor cable |

Software and configuration utilities

Server mode

The software and configuration utilities presented in this section operate in online mode, offline mode, or in both modes.

| Software or configuration utility | Server mode |
|--|--------------------|
| HP iLO (on page 90) | Online and Offline |
| Active Health System (on page 91) | Online and Offline |
| RESTful API support for iLO (on page 92) | Online and Offline |
| Integrated Management Log (on page 92) | Online and Offline |
| Intelligent Provisioning (on page 92) | Offline |
| HP Insight Diagnostics (on page 93) | Online and Offline |
| Erase Utility (on page 93) | Offline |
| Scripting Toolkit for Windows and Linux (on page 94) | Online |
| Service Pack for ProLiant (on page 94) | Online and Offline |
| HP Smart Update Manager (on page 94) | Online and Offline |
| HP UEFI System Utilities (on page 94) | Offline |
| HP Smart Storage Administrator (on page 97) | Online and Offline |
| FWUPDATE utility (on page 99) | Offline |

Product QuickSpecs

For more information about product features, specifications, options, configurations, and compatibility, see the product QuickSpecs on the Hewlett Packard Enterprise website (<http://www.hpe.com/info/qs>).

HP iLO

The iLO 4 subsystem is a standard component of ProLiant servers that simplifies initial server setup, server health monitoring, power and thermal optimization, and remote server administration. The iLO 4 subsystem includes an intelligent microprocessor, secure memory, and a dedicated network interface. This design makes iLO 4 independent of the host server and its operating system.

iLO 4 enables and manages the Active Health System (on page 91) and also features Agentless Management. All key internal subsystems are monitored by iLO 4. If enabled, SNMP alerts are sent directly by iLO 4 regardless of the host operating system or even if no host operating system is installed.

Using iLO 4, you can do the following:

- Access a high-performance and secure Integrated Remote Console to the server from anywhere in the world if you have a network connection to the server.
- Use the shared .NET Integrated Remote Console to collaborate with up to four server administrators.
- Remotely mount high-performance Virtual Media devices to the server.
- Securely and remotely control the power state of the managed server.

- Implement true Agentless Management with SNMP alerts from iLO, regardless of the state of the host server.
- Download the Active Health System log.
- Register for HPE remote support.
- Use iLO Federation to manage multiple servers from one system running the iLO web interface.
- Use Virtual Power and Virtual Media from the GUI, the CLI, or the iLO scripting toolkit for many tasks, including the automation of deployment and provisioning.
- Control iLO 4 by using a remote management tool.

For more information about iLO 4 features, see the iLO 4 documentation on the Hewlett Packard Enterprise website (<http://www.hpe.com/info/ilo/docs>).

The iLO 4 hardware and firmware features and functionality, such as NAND size and embedded user partition, vary depending on the server model. For a complete list of supported features and functionality, see the iLO 4 QuickSpecs on the Hewlett Packard Enterprise website (<http://www.hpe.com/info/Quickspecs-iLO>).

Active Health System

The HPE Active Health System provides the following features:

- Combined diagnostics tools/scanners
- Always on, continuous monitoring for increased stability and shorter downtimes
- Rich configuration history
- Health and service alerts
- Easy export and upload to Service and Support

The Active Health System monitors and records changes in the server hardware and system configuration. The Active Health System assists in diagnosing problems and delivering rapid resolution if server failures occur.

The Active Health System collects the following types of data:

- Server model
- Serial number
- Processor model and speed
- Storage capacity and speed
- Memory capacity and speed
- Firmware/BIOS

Active Health System does not collect information about Active Health System users' operations, finances, customers, employees, partners, or data center, such as IP addresses, host names, user names, and passwords. Active Health System does not parse or change operating system data from third-party error event log activities, such as content created or passed through by the operating system.

The data that is collected is managed according to the Hewlett Packard Enterprise Data Privacy policy. For more information see the Hewlett Packard Enterprise website (<http://www.hpe.com/info/privacy>).

The Active Health System, in conjunction with the system monitoring provided by Agentless Management or SNMP Pass-thru, provides continuous monitoring of hardware and configuration changes, system status, and service alerts for various server components.

The Agentless Management Service is available in the SPP, which can be downloaded from the Hewlett Packard Enterprise website (<http://www.hpe.com/servers/spp/download>). The Active Health System

log can be downloaded manually from iLO 4 or HPE Intelligent Provisioning and sent to Hewlett Packard Enterprise.

For more information, see the following documents:

- *iLO User Guide* on the Hewlett Packard Enterprise website (<http://www.hpe.com/info/ilo/docs>)
- *Intelligent Provisioning User Guide* on the Hewlett Packard Enterprise website (<http://www.hpe.com/info/intelligentprovisioning/docs>)

RESTful API support for iLO

HPE iLO 4 firmware version 2.00 and later includes the RESTful API. The RESTful API is a management interface that server management tools can use to perform configuration, inventory, and monitoring of the ProLiant server via iLO. The RESTful API uses basic HTTPS operations (GET, PUT, POST, DELETE, and PATCH) to submit or return JSON-formatted data with iLO web server.

HPE iLO 4 2.30 and later is Redfish 1.0-conformant while remaining backward compatible with the existing RESTful API.

HPE iLO 4 supports the RESTful API with ProLiant Gen8 and later servers. For more information about the RESTful API, see the Hewlett Packard Enterprise website (<http://www.hpe.com/info/restfulinterface/docs>).

Integrated Management Log

The IML records hundreds of events and stores them in an easy-to-view form. The IML timestamps each event with 1-minute granularity.

You can view recorded events in the IML in several ways, including the following:

- From within HPE SIM
- From within UEFI System Utilities ("[HPE UEFI System Utilities](#)" on page [94](#))
- From within the Embedded UEFI shell (on page [96](#))
- From within operating system-specific IML viewers:
 - For Windows: IML Viewer
 - For Linux: IML Viewer Application
- From within the iLO web interface
- From within Insight Diagnostics ("[HPE Insight Diagnostics](#)" on page [93](#))

Intelligent Provisioning

Intelligent Provisioning is a single-server deployment tool embedded in ProLiant Gen8 and later servers that simplifies ProLiant server setup, providing a reliable and consistent way to deploy ProLiant server configurations:

- Intelligent Provisioning assists with the OS installation process by preparing the system for installing "off-the-shelf" and Hewlett Packard Enterprise branded versions of operating system software and integrating optimized ProLiant server support software.
- Intelligent Provisioning provides maintenance-related tasks using the Perform Maintenance window.
- Intelligent Provisioning provides installation help for Microsoft Windows, Red Hat and SUSE Linux, and VMware operating systems. For specific OS support, see the *Intelligent Provisioning Release Notes* on the Hewlett Packard Enterprise website (<http://www.hpe.com/info/intelligentprovisioning/docs>).

For more information about Intelligent Provisioning software, see the Hewlett Packard Enterprise website (<http://www.hpe.com/servers/intelligentprovisioning>). For Intelligent Provisioning recovery media downloads, see the Resources tab on the Hewlett Packard Enterprise website (<http://www.hpe.com/servers/intelligentprovisioning>). For consolidated drive and firmware update packages, see the Smart Update: Server Firmware and Driver Updates page on the Hewlett Packard Enterprise website (<http://www.hpe.com/info/SmartUpdate>).

HPE Insight Diagnostics

The Insight Diagnostics is a proactive server management tool, available in both offline and online versions, that provides diagnostics and troubleshooting capabilities to assist IT administrators who verify server installations, troubleshoot problems, and perform repair validation.

The Insight Diagnostics Offline Edition performs various in-depth system and component testing while the OS is not running. To run this utility, boot the server using Intelligent Provisioning (on page 92).

The Insight Diagnostics Online Edition is a web-based application that captures system configuration and other related data needed for effective server management. Available in Microsoft Windows and Linux versions, the utility helps to ensure proper system operation.

For more information or to download the utility, see the Hewlett Packard Enterprise website (<http://www.hpe.com/info/InsightDiagnostics>). The Insight Diagnostics Online Edition is also available in the SPP ("[Service Pack for ProLiant](#)" on page 94).

HPE Insight Diagnostics survey functionality

HPE Insight Diagnostics (on page 93) provides survey functionality that gathers critical hardware and software information on ProLiant servers.

This functionality supports operating systems that are supported by the server. For operating systems supported by the server, see the Hewlett Packard Enterprise website (<http://www.hpe.com/info/supportos>).

If a significant change occurs between data-gathering intervals, the survey function marks the previous information and overwrites the survey data files to reflect the latest changes in the configuration.

Survey functionality is installed with every Intelligent Provisioning-assisted Insight Diagnostics installation, or it can be installed through the SPP ("[Service Pack for ProLiant](#)" on page 94).

Erase Utility



CAUTION: Perform a backup before running the Erase Utility. The utility sets the system to its original factory state, deletes the current hardware configuration information, including array setup and disk partitioning, and erases all connected hard drives completely. Before using this utility, see the instructions in the *Intelligent Provisioning User Guide*.

Use the Erase Utility to erase drives and Active Health System logs, and to reset RBSU settings. Run the Erase Utility if you must erase the system for the following reasons:

- You want to install a new operating system on a server with an existing operating system.
- You encounter an error when completing the steps of a factory-installed operating system installation.

To access the Erase Utility, click the Perform Maintenance icon from the Intelligent Provisioning home screen, and then select **Erase**.

For more information about the Erase Utility, see the Intelligent Provisioning user guide on the Hewlett Packard Enterprise website (<http://www.hpe.com/info/intelligentprovisioning/docs>).

Scripting Toolkit for Windows and Linux

The STK for Windows and Linux is a server deployment product that delivers an unattended automated installation for high-volume server deployments. The STK is designed to support ProLiant servers. The toolkit includes a modular set of utilities and important documentation that describes how to apply these tools to build an automated server deployment process.

The STK provides a flexible way to create standard server configuration scripts. These scripts are used to automate many of the manual steps in the server configuration process. This automated server configuration process cuts time from each deployment, making it possible to scale rapid, high-volume server deployments.

For more information or to download the STK, see the Hewlett Packard Enterprise website (<http://www.hpe.com/servers/proliant/stk>).

Service Pack for ProLiant

The SPP is a comprehensive systems software (drivers and firmware) solution delivered as a single package with major server releases. This solution uses HP SUM as the deployment tool and is tested on all supported ProLiant servers including ProLiant Gen8 and later servers.

SPP can be used in an online mode on a Windows or Linux hosted operating system, or in an offline mode where the server is booted to an operating system included on the ISO file so that the server can be updated automatically with no user interaction or updated in interactive mode.

For more information or to download SPP, see one of the following pages on the Hewlett Packard Enterprise website:

- Service Pack for ProLiant download page (<http://www.hpe.com/servers/spp/download>)
- Smart Update: Server Firmware and Driver Updates page (<http://www.hpe.com/info/SmartUpdate>)

HP Smart Update Manager

HP SUM is a product used to install and update firmware, drivers, and systems software on ProLiant servers. The HP SUM provides a GUI and a command-line scriptable interface for deployment of systems software for single or one-to-many ProLiant servers and network-based targets, such as iLOs, OAs, and VC Ethernet and Fibre Channel modules.

For more information about HP SUM, see the product page on the Hewlett Packard Enterprise website (<http://www.hpe.com/servers/hpsum>).

To download HP SUM, see the Hewlett Packard Enterprise website (<http://www.hpe.com/servers/hpsum/download>).

To access the *HP Smart Update Manager User Guide*, see the HP SUM Information Library (<http://www.hpe.com/info/hpsum/documentation>).

HPE UEFI System Utilities

The UEFI System Utilities is embedded in the system ROM. The UEFI System Utilities enable you to perform a wide range of configuration activities, including:

- Configuring system devices and installed options
- Enabling and disabling system features
- Displaying system information
- Selecting the primary boot controller

- Configuring memory options
- Selecting a language
- Launching other pre-boot environments such as the Embedded UEFI Shell and Intelligent Provisioning

For more information on the UEFI System Utilities, see the *HPE UEFI System Utilities User Guide for HPE ProLiant Gen9 Servers* on the Hewlett Packard Enterprise website (<http://www.hpe.com/info/uefi/docs>).

Scan the QR code located at the bottom of the screen to access mobile-ready online help for the UEFI System Utilities and UEFI Shell. For on-screen help, press **F1**.

Using UEFI System Utilities

To use the UEFI System Utilities, use the following keys.

| Action | Key |
|---|-----------------------|
| Access System Utilities | F9 during server POST |
| Navigate menus | Up and Down arrows |
| Select items | Enter |
| Save selections | F10 |
| Access Help for a highlighted configuration option* | F1 |

*Scan the QR code on the screen to access online help for the UEFI System Utilities and UEFI Shell.

Default configuration settings are applied to the server at one of the following times:

- Upon the first system power-up
- After defaults have been restored

Default configuration settings are sufficient for typical server operations; however, you can modify configuration settings as needed. The system prompts you for access to the UEFI System Utilities each time the system is powered up.

Flexible boot control

This feature enables you to do the following:

- Add Boot Options
 - Browse all FAT16 and FAT32 file systems.
 - Select an X64 UEFI application with an .EFI extension to add as a new UEFI boot option, such as an OS boot loader or other UEFI application.

The new boot option is appended to the boot order list. When you select a file, you are prompted to enter the boot option description (which is then displayed in the Boot menu), as well as any optional data to be passed to an .EFI application.
- Boot to System Utilities

After pre-POST, the boot options screen appears. During this time, you can access the UEFI System Utilities by pressing the **F9** key.
- Choose between supported modes: Legacy BIOS Boot Mode or UEFI Boot Mode



IMPORTANT: If the default boot mode settings are different than the user defined settings, the system may not boot the OS installation if the defaults are restored. To avoid this issue, use the User Defined Defaults feature in UEFI System Utilities to override the factory default settings.

For more information, see the *HPE UEFI System Utilities User Guide for HPE ProLiant Gen9 Servers* on the Hewlett Packard Enterprise website (<http://www.hpe.com/info/uefi/docs>).

Restoring and customizing configuration settings

You can reset all configuration settings to the factory default settings, or you can restore system default configuration settings, which are used instead of the factory default settings.

You can also configure default settings as necessary, and then save the configuration as the custom default configuration. When the system loads the default settings, it uses the custom default settings instead of the factory defaults.

Secure Boot configuration

Secure Boot is integrated in the UEFI specification on which the Hewlett Packard Enterprise implementation of UEFI is based. Secure Boot is completely implemented in the BIOS and does not require special hardware. It ensures that each component launched during the boot process is digitally signed and that the signature is validated against a set of trusted certificates embedded in the UEFI BIOS. Secure Boot validates the software identity of the following components in the boot process:

- UEFI drivers loaded from PCIe cards
- UEFI drivers loaded from mass storage devices
- Pre-boot UEFI shell applications
- OS UEFI boot loaders

Once enabled, only firmware components and operating systems with boot loaders that have an appropriate digital signature can execute during the boot process. Only operating systems that support Secure Boot and have an EFI boot loader signed with one of the authorized keys can boot when Secure Boot is enabled. For more information about supported operating systems, see the *HPE UEFI System Utilities and Shell Release Notes for HPE ProLiant Gen9 Servers* on the Hewlett Packard Enterprise website (<http://www.hpe.com/info/uefi/docs>).

A physically present user can customize the certificates embedded in the UEFI BIOS by adding/removing their own certificates.

When Secure Boot is enabled, the System Maintenance Switch does not restore all manufacturing defaults when set to the ON position. For security reasons, the following are not restored to defaults when the System Maintenance Switch is in the ON position:

- Secure Boot is not disabled and remains enabled.
- The Boot Mode remains in UEFI Boot Mode even if the default boot mode is Legacy Boot Mode.
- The Secure Boot Database is not restored to its default state.
- iSCSI Software Initiator configuration settings are not restored to defaults.

Embedded UEFI shell

The system BIOS in all ProLiant Gen9 servers includes an Embedded UEFI Shell in the ROM. The UEFI Shell environment provides an API, a command line prompt, and a set of CLIs that allow scripting, file manipulation, and system information. These features enhance the capabilities of the UEFI System Utilities.

For more information, see the following documents:

- *HPE UEFI Shell User Guide for HPE ProLiant Gen9 Servers* on the Hewlett Packard Enterprise website (<http://www.hpe.com/info/uefi/docs>)
- *UEFI Shell Specification* on the UEFI website (<http://www.uefi.org/specifications>)

Embedded Diagnostics option

The system BIOS in all ProLiant Gen9 servers includes an Embedded Diagnostics option in the ROM. The Embedded Diagnostics option can run comprehensive diagnostics of the server hardware, including processors, memory, drives, and other server components.

For more information on the Embedded Diagnostics option, see the *HPE UEFI System Utilities User Guide for HPE ProLiant Gen9 Servers* on the Hewlett Packard Enterprise website (<http://www.hpe.com/info/uefi/docs>).

RESTful API support for UEFI

The ProLiant Gen9 servers include support for a UEFI compliant System BIOS, along with UEFI System Utilities and Embedded UEFI Shell pre-boot environments. ProLiant Gen9 servers also support configuring the UEFI BIOS settings using the RESTful API, a management interface that server management tools can use to perform configuration, inventory, and monitoring of a ProLiant server. The RESTful API uses basic HTTPS operations (GET, PUT, POST, DELETE, and PATCH) to submit or return JSON-formatted data with iLO web server.

For more information about the RESTful API and the RESTful Interface Tool, see the Hewlett Packard Enterprise website (<http://www.hpe.com/info/restfulinterface/docs>).

Re-entering the server serial number and product ID

After you replace the system board, you must re-enter the server serial number and the product ID.

1. During the server startup sequence, press the **F9** key to access UEFI System Utilities.
2. Select the **System Configuration > BIOS/Platform Configuration (RBSU) > Advanced Options > Advanced System ROM Options > Serial Number**, and then press the **Enter** key.
3. Enter the serial number and press the **Enter** key. The following message appears:

```
The serial number should only be modified by qualified service personnel.
This value should always match the serial number located on the chassis.
```
4. Press the **Enter** key to clear the warning.
5. Enter the serial number and press the **Enter** key.
6. Select **Product ID**. The following warning appears:

```
Warning: The Product ID should ONLY be modified by qualified service
personnel. This value should always match the Product ID located on the
chassis.
```
7. Enter the product ID and press the **Enter** key.
8. Press the **F10** key to confirm exiting System Utilities. The server automatically reboots.

Utilities and features

HPE Smart Storage Administrator

The HPE SSA is a configuration and management tool for HPE Smart Array controllers. Starting with HPE ProLiant Gen8 servers, HPE SSA replaces ACU with an enhanced GUI and additional configuration features.

The HPE SSA exists in three interface formats: the HPE SSA GUI, the HPE SSA CLI, and HPE SSA Scripting. Although all formats provide support for configuration tasks, some of the advanced tasks are available in only one format.

Some HPE SSA features include the following:

- Supports online array capacity expansion, logical drive extension, assignment of online spares, and RAID or stripe size migration
- Provides diagnostic and SmartSSD Wear Gauge functionality on the Diagnostics tab
- For supported controllers, provides access to additional features.

For more information about HPE SSA, see the Hewlett Packard Enterprise website (<http://www.hpe.com/servers/ssa>).

Automatic Server Recovery

ASR is a feature that causes the system to restart when a catastrophic operating system error occurs, such as a blue screen, ABEND, or panic. A system fail-safe timer, the ASR timer, starts when the System Management driver, also known as the Health Driver, is loaded. When the operating system is functioning properly, the system periodically resets the timer. However, when the operating system fails, the timer expires and restarts the server.

ASR increases server availability by restarting the server within a specified time after a system hang. You can disable ASR from the System Management Homepage or through UEFI System Utilities.

USB support

Hewlett Packard Enterprise provides both standard USB 2.0 support and legacy USB 2.0 support. Standard support is provided by the OS through the appropriate USB device drivers. Before the OS loads, Hewlett Packard Enterprise provides support for USB devices through legacy USB support, which is enabled by default in the system ROM.

Legacy USB support provides USB functionality in environments where USB support is not available normally. Specifically, Hewlett Packard Enterprise provides legacy USB functionality for the following:

- POST (system boot)
- UEFI System Utilities
- Pre-boot UEFI shell
- DOS
- Operating environments which do not provide native USB support

External USB functionality

Hewlett Packard Enterprise provides external USB support to enable local connection of USB devices for server administration, configuration, and diagnostic procedures.

For additional security, external USB functionality can be disabled through USB options in UEFI System Utilities.

Redundant ROM support

The server enables you to upgrade or configure the ROM safely with redundant ROM support. The server has a single ROM that acts as two separate ROM images. In the standard implementation, one side of the ROM contains the current ROM program version, while the other side of the ROM contains a backup version.

NOTE: The server ships with the same version programmed on each side of the ROM.

Safety and security benefits

When you flash the system ROM, the flashing mechanism writes over the backup ROM and saves the current ROM as a backup, enabling you to switch easily to the alternate ROM version if the new ROM becomes corrupted for any reason. This feature protects the existing ROM version, even if you experience a power failure while flashing the ROM.

Keeping the system current

Access to Hewlett Packard Enterprise Support Materials

Access to some updates for ProLiant Servers may require product entitlement when accessed through the Hewlett Packard Enterprise Support Center support portal. Hewlett Packard Enterprise recommends that you have an HP Passport set up with relevant entitlements. For more information, see the Hewlett Packard Enterprise website (<http://www.hpe.com/support/AccessToSupportMaterials>).

Updating firmware or System ROM

Multiple methods exist to update the firmware or System ROM:

- Service Pack for ProLiant (on page 94)
- FWUPDATE utility (on page 99)
- FWUpdate command from within the Embedded UEFI shell (on page 100)
- Firmware Update application in UEFI System Utilities ("[Firmware Update application in the UEFI System Utilities](#)" on page 100)
- Online Flash components (on page 100)

Product entitlement is required to perform updates. For more information, see "Accessing updates ("[Access to Hewlett Packard Enterprise Support Materials](#)" on page 99)."

FWUPDATE utility

The FWUPDATE utility enables you to upgrade the system firmware (BIOS).

To use the utility to upgrade the firmware:

1. Download the FWUPDATE flash component from the Hewlett Packard Enterprise Support Center website (<http://www.hpe.com/support/hpesc>).
2. Save the FWUPDATE flash components to a USB key.
3. Set the boot order so the USB key will boot first using one of the following options:
 - Configure the boot order so the USB key is the first bootable device.
 - Press **F11** (Boot Menu) when prompted during system boot to access the **One-Time Boot Menu**. This menu allows you to select the boot device for a specific boot and does not modify the boot order configuration settings.
4. Insert the USB key into an available USB port.
5. Boot the system.

The FWUPDATE utility checks the system and provides a choice (if more than one exists) of available firmware revisions.

To download the flash components, see the Hewlett Packard Enterprise Support Center website (<http://www.hpe.com/support/hpesc>).

For more information about the One-Time Boot Menu, see the *HPE UEFI System Utilities User Guide for HPE ProLiant Gen9 Servers* on the Hewlett Packard Enterprise website (<http://www.hpe.com/info/uefi/docs>).

FWUpdate command from within the Embedded UEFI Shell

For systems configured in either boot mode, update the firmware:

1. Access the System ROM Flash Binary component for your server from the Hewlett Packard Enterprise Support Center website (<http://www.hpe.com/support/hpesc>). When searching for the component, always select **OS Independent** to locate the binary file.
2. Copy the binary file to a USB media or iLO virtual media.
3. Attach the media to the server.
4. Boot to Embedded Shell.
5. To obtain the assigned file system volume for the USB key, enter `Map -r`. For more information about accessing a file system from the shell, see the *HPE UEFI Shell User Guide for HPE ProLiant Gen9 Servers* on the Hewlett Packard Enterprise website (<http://www.hpe.com/info/uefi/docs>).
6. Change to the file system that contains the System ROM Flash Binary component for your server. Enter one of the fsx file systems available, such as `fs0` or `fs1`, and press **Enter**.
7. Use the `cd` command to change from the current directory to the directory that contains the binary file.
8. Enter `fwupdate -d BIOS -f <filename>` to flash the system ROM.

For help on the FWUPDATE command, enter the command:

```
help fwupdate -b
```

9. Reboot the server. A reboot is required after the firmware update for the updates to take effect and for hardware stability to be maintained.

For more information about the commands used in this procedure, see the *HPE UEFI Shell User Guide for HPE ProLiant Gen9 Servers* on the Hewlett Packard Enterprise website (<http://www.hpe.com/info/uefi/docs>).

Firmware Update application in the UEFI System Utilities

For systems configured in either boot mode, update the firmware:

1. Access the System ROM Flash Binary component for your server from the Hewlett Packard Enterprise Support Center website (<http://www.hpe.com/support/hpesc>). When searching for the component, always select **OS Independent** to find the component.
2. Copy the binary file to a USB media or iLO virtual media.
3. Attach the media to the server.
4. During POST, press **F9** to enter System Utilities.
5. Select **Embedded Applications** → **Firmware Update** → **System ROM** → **Select Firmware File**.
6. Select the device containing the flash file.
7. Select the flash file. This step may take a few moments to complete.
8. Select **Start firmware update** and allow the process to complete.
9. Reboot the server. A reboot is required after the firmware update for the updates to take effect and for hardware stability to be maintained.

Online Flash components

This component provides updated system firmware that can be installed directly on supported operating systems. Additionally, when used in conjunction with the HP SUM ("HP Smart Update Manager" on page 94), this Smart Component allows the user to update firmware on remote servers from a central location.

This remote deployment capability eliminates the need for the user to be physically present at the server to perform a firmware update.

Drivers



IMPORTANT: Always perform a backup before installing or updating device drivers.

The server includes new hardware that may not have driver support on all OS installation media.

If you are installing an Intelligent Provisioning-supported OS, use Intelligent Provisioning (on page 92) and its Configure and Install feature to install the OS and latest supported drivers.

If you do not use Intelligent Provisioning to install an OS, drivers for some of the new hardware are required. These drivers, as well as other option drivers, ROM images, and value-add software can be downloaded as part of an SPP.

If you are installing drivers from SPP, be sure that you are using the latest SPP version that your server supports. To verify that your server is using the latest supported version and for more information about SPP, see the Hewlett Packard Enterprise website (<http://www.hpe.com/servers/spp/download>).

To locate the drivers for a particular server, go to the Hewlett Packard Enterprise Support Center website (<http://www.hpe.com/support/hpesc>). Under **Select your HPE product**, enter the product name or number and click **Go**.

Software and firmware

Software and firmware should be updated before using the server for the first time, unless any installed software or components require an older version.

For system software and firmware updates, use one of the following sources:

- Download the SPP ("Service Pack for ProLiant" on page 94) from the Hewlett Packard Enterprise website (<http://www.hpe.com/servers/spp/download>).
- Download individual drivers, firmware, or other systems software components from the server product page in the Hewlett Packard Enterprise Support Center website (<http://www.hpe.com/support/hpesc>).

Operating System Version Support

For information about specific versions of a supported operating system, refer to the operating system support matrix (<http://www.hpe.com/info/ossupport>).

Version control

The VCRM and VCA are web-enabled Insight Management Agents tools that SIM uses to schedule software update tasks to the entire enterprise.

- VCRM manages the repository for SPP. Administrators can view the SPP contents or configure VCRM to automatically update the repository with internet downloads of the latest software and firmware from Hewlett Packard Enterprise.
- VCA compares installed software versions on the node with updates available in the VCRM managed repository. Administrators configure VCA to point to a repository managed by VCRM.

For more information about version control tools, see the *Systems Insight Manager User Guide*, the *Version Control Agent User Guide*, and the *Version Control Repository Manager User Guide* on the Hewlett Packard Enterprise website (<http://www.hpe.com/info/enterprise/docs>).

1. Select **HP Insight Management** from the available options in Products and Solutions.

2. Select **HP Version Control** from the available options in Insight Management.
3. Download the latest document.

Operating systems and virtualization software support for ProLiant servers

For information about specific versions of a supported operating system, see the Hewlett Packard Enterprise website (<http://www.hpe.com/info/ossupport>).

HPE Technology Service Portfolio

Connect to Hewlett Packard Enterprise for assistance on the journey to the new style of IT. The Hewlett Packard Enterprise Technology Services delivers confidence and reduces risk to help you realize agility and stability in your IT infrastructure.

Utilize our consulting expertise in the areas of private or hybrid cloud computing, big data and mobility requirements, improving data center infrastructure and better use of today's server, storage and networking technology. For more information, see the Hewlett Packard Enterprise website (<http://www.hpe.com/services/consulting>).

Our support portfolio covers services for server, storage and networking hardware and software plus the leading industry standard operating systems. Let us work proactively with you to prevent problems. Our flexible choices of hardware and software support coverage windows and response times help resolve problems faster, reduce unplanned outages and free your staff for more important tasks. For more information, see the Hewlett Packard Enterprise website (<http://www.hpe.com/services/support>).

Tap into our knowledge, expertise, innovation and world-class services to achieve better results. Access and apply technology in new ways to optimize your operations and you'll be positioned for success.

Change control and proactive notification

Hewlett Packard Enterprise offers Change Control and Proactive Notification to notify customers 30 to 60 days in advance of upcoming hardware and software changes on Hewlett Packard Enterprise commercial products.

For more information, see the Hewlett Packard Enterprise website (<http://www.hpe.com/info/pcn>).

Troubleshooting

Troubleshooting resources

The *HPE ProLiant Gen9 Troubleshooting Guide, Volume I: Troubleshooting* provides procedures for resolving common problems and comprehensive courses of action for fault isolation and identification, issue resolution, and software maintenance on ProLiant servers and server blades. To view the guide, select a language:

- English (http://www.hpe.com/support/Gen9_TSG_en)
- French (http://www.hpe.com/support/Gen9_TSG_fr)
- Spanish (http://www.hpe.com/support/Gen9_TSG_es)
- German (http://www.hpe.com/support/Gen9_TSG_de)
- Japanese (http://www.hpe.com/support/Gen9_TSG_ja)
- Simplified Chinese (http://www.hpe.com/support/Gen9_TSG_zh_cn)

The *HPE ProLiant Gen9 Troubleshooting Guide, Volume II: Error Messages* provides a list of error messages and information to assist with interpreting and resolving error messages on ProLiant servers and server blades. To view the guide, select a language:

- English (http://www.hpe.com/support/Gen9_EMG_en)
- French (http://www.hpe.com/support/Gen9_EMG_fr)
- Spanish (http://www.hpe.com/support/Gen9_EMG_es)
- German (http://www.hpe.com/support/Gen9_EMG_de)
- Japanese (http://www.hpe.com/support/Gen9_EMG_ja)
- Simplified Chinese (http://www.hpe.com/support/Gen9_EMG_zh_cn)

System battery replacement

If the server no longer automatically displays the correct date and time, then replace the battery that provides power to the real-time clock. Under normal use, battery life is 5 to 10 years.

- ⚠ WARNING:** The computer contains an internal lithium manganese dioxide, a vanadium pentoxide, or an alkaline battery pack. A risk of fire and burns exists if the battery pack is not properly handled. To reduce the risk of personal injury:
- Do not attempt to recharge the battery.
 - Do not expose the battery to temperatures higher than 60°C (140°F).
 - Do not disassemble, crush, puncture, short external contacts, or dispose of in fire or water.
 - Replace only with the spare designated for this product.

To remove the component:

1. Power down the server (on page 15).
2. Remove all power:
 - a. Disconnect each power cord from the power source.
 - b. Disconnect each power cord from the server.
3. Do one of the following:
 - o Extend the server from the rack (on page 15).
 - o Remove the server from the rack (on page 18).
4. Remove the access panel (on page 18).
5. Remove the secondary PCI riser cage. ("Remove the PCI riser cage" on page 21)
6. If installed, remove any expansion board installed in slot 1.
7. Locate the battery on the system board ("System board components" on page 10).
8. Remove the battery.

Use a small flat-bladed, nonconductive tool to carefully remove the battery from the socket.

- ⚠ WARNING:** Do not exert too much force to remove the system battery. The battery could pop out of the socket, or the tool could slip and damage the socket or the system board.

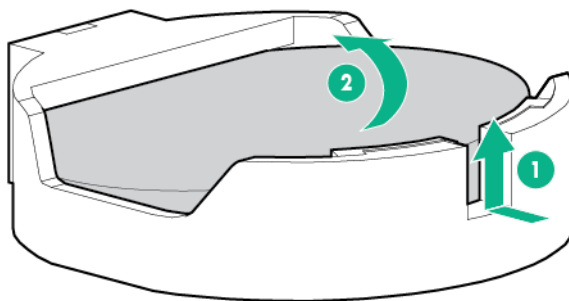

- ⚠ IMPORTANT:** Replacing the system board battery resets the system ROM to its default configuration. After replacing the battery, use BIOS/Platform Configuration (RBSU) in the UEFI System Utilities ("HPE UEFI System Utilities" on page 94) to reconfigure the system.

To replace the component:

1. Insert the battery with the "+" side facing up underneath the outer lip of the socket, and then press the battery down to secure it in place.

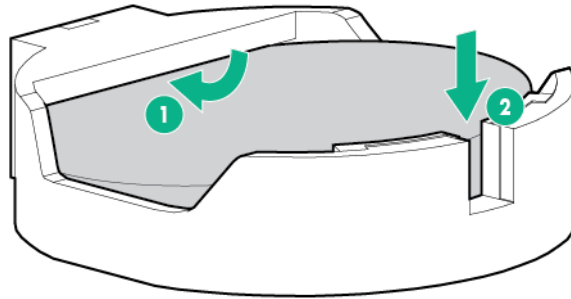

2. Install the access panel (on page 19).
3. Do one of the following:
 - o Slide the server into the rack.
 - o Install the server into the rack.
4. Power up the server (on page 15).

For more information about battery replacement or proper disposal, contact an authorized reseller or an authorized service provider.

Warranty and regulatory information

Warranty information

HPE ProLiant and x86 Servers and Options

(<http://www.hpe.com/support/ProLiantServers-Warranties>)

HPE Enterprise Servers (<http://www.hpe.com/support/EnterpriseServers-Warranties>)

HPE Storage Products (<http://www.hpe.com/support/Storage-Warranties>)

HPE Networking Products (<http://www.hpe.com/support/Networking-Warranties>)

Regulatory information

Safety and regulatory compliance

For important safety, environmental, and regulatory information, see *Safety and Compliance Information for Server, Storage, Power, Networking, and Rack Products*, available at the Hewlett Packard Enterprise website (<http://www.hpe.com/support/Safety-Compliance-EnterpriseProducts>).

Belarus Kazakhstan Russia marking



Manufacturer and Local Representative Information

Manufacturer information:

Hewlett Packard Enterprise Company, 3000 Hanover Street, Palo Alto, CA 94304 U.S.

Local representative information Russian:

- **Russia:**

ООО «Хьюлетт Паккард Энтерпрайз», Российская Федерация, 125171, г. Москва, Ленинградское шоссе, 16А, стр.3, Телефон/факс: +7 495 797 35 00

- **Belarus:**

ИООО «Хьюлетт-Паккард Бел», Республика Беларусь, 220030, г. Минск, ул. Интернациональная, 36-1, Телефон/факс: +375 17 392 28 20

- **Kazakhstan:**

ТОО «Хьюлетт-Паккард (К)», Республика Казахстан, 050040, г. Алматы, Бостандыкский район, проспект Аль-Фараби, 77/7, Телефон/факс: + 7 727 355 35 52

Local representative information Kazakh:

- **Russia:**

ЖШС "Хьюлетт Паккард Энтерпрайз", Ресей Федерациясы, 125171,
Мәскеу, Ленинград тас жолы, 16А блок 3, Телефон/факс: +7 495 797 35 00

- **Belarus:**

«HEWLETT-PACKARD Bel» ЖШС, Беларусь Республикасы, 220030, Минск қ.,
Интернациональная көшесі, 36/1, Телефон/факс: +375 17 392 28 20

- **Kazakhstan:**

ЖШС «Хьюлетт-Паккард (К)», Қазақстан Республикасы, 050040, Алматы қ.,
Бостандық ауданы, Әл-Фараби даңғылы, 77/7, Телефон/факс: +7 727 355 35 52

Manufacturing date:

The manufacturing date is defined by the serial number.

CCSYWWZZZZ (serial number format for this product)

Valid date formats include:

- YWW, where Y indicates the year counting from within each new decade, with 2000 as the starting point; for example, 238: 2 for 2002 and 38 for the week of September 9. In addition, 2010 is indicated by 0, 2011 by 1, 2012 by 2, 2013 by 3, and so forth.
- YYWW, where YY indicates the year, using a base year of 2000; for example, 0238: 02 for 2002 and 38 for the week of September 9.

Turkey RoHS material content declaration

Türkiye Cumhuriyeti: EEE Yönetmeliğine Uygundur

Ukraine RoHS material content declaration

Обладнання відповідає вимогам Технічного регламенту щодо обмеження використання деяких небезпечних речовин в електричному та електронному обладнанні, затвердженого постановою Кабінету Міністрів України від 3 грудня 2008 № 1057

Electrostatic discharge

Preventing electrostatic discharge

To prevent damaging the system, be aware of the precautions you need to follow when setting up the system or handling parts. A discharge of static electricity from a finger or other conductor may damage system boards or other static-sensitive devices. This type of damage may reduce the life expectancy of the device.

To prevent electrostatic damage:

- Avoid hand contact by transporting and storing products in static-safe containers.
- Keep electrostatic-sensitive parts in their containers until they arrive at static-free workstations.
- Place parts on a grounded surface before removing them from their containers.
- Avoid touching pins, leads, or circuitry.
- Always be properly grounded when touching a static-sensitive component or assembly.

Grounding methods to prevent electrostatic discharge

Several methods are used for grounding. Use one or more of the following methods when handling or installing electrostatic-sensitive parts:

- Use a wrist strap connected by a ground cord to a grounded workstation or computer chassis. Wrist straps are flexible straps with a minimum of 1 megohm \pm 10 percent resistance in the ground cords. To provide proper ground, wear the strap snug against the skin.
- Use heel straps, toe straps, or boot straps at standing workstations. Wear the straps on both feet when standing on conductive floors or dissipating floor mats.
- Use conductive field service tools.
- Use a portable field service kit with a folding static-dissipating work mat.

If you do not have any of the suggested equipment for proper grounding, have an authorized reseller install the part.

For more information on static electricity or assistance with product installation, contact an authorized reseller.

Specifications

Environmental specifications

| Specification | Value |
|--|--|
| Temperature range* | — |
| Operating | 10°C to 35°C (50°F to 95°F) |
| Nonoperating | -30°C to 60°C (-22°F to 140°F) |
| Relative humidity (noncondensing) | — |
| Operating | Minimum to be the higher (more moisture) of -12°C (10.4°F) dew point or 8% relative humidity Maximum to be 24°C (75.2°F) dew point or 90% relative humidity |
| Nonoperating | 5% to 95% 38.7°C (101.7°F), maximum wet bulb temperature |

* All temperature ratings shown are for sea level. An altitude derating of 1.0°C per 304.8 m (1.8°F per 1000 ft) to 3048 m (10,000 ft) is applicable. No direct sunlight allowed. Maximum rate of change is 20°C per hour (36°F per hour). The upper limit and rate of change might be limited by the type and number of options installed.

For certain approved hardware configurations, the supported system inlet temperature range is extended:

- 5°C to 10°C (41°F to 50°F) and 35°C to 40°C (95°F to 104°F) at sea level with an altitude derating of 1.0°C per every 175 m (1.8°F per every 574 ft) above 900 m (2953 ft) to a maximum of 3048 m (10,000 ft).
- 40°C to 45°C (104°F to 113°F) at sea level with an altitude derating of 1.0°C per every 125 m (1.8°F per every 410 ft) above 900 m (2953 ft) to a maximum of 3048 m (10,000 ft).

The approved hardware configurations for this system are listed on the Hewlett Packard Enterprise website (<http://www.hpe.com/servers/ASHRAE>).

Mechanical specifications

| Specification | Value |
|----------------------------|--|
| Height | 4.29 cm (1.69 in) |
| Depth | 60.70 cm (23.90 in) |
| Width | 43.46 cm (17.11 in) |
| Weight (approximate range) | 9.00 kg to 17.00 kg (19.82 lb to 37.44 lb) |

Power supply specifications

Depending on the installed options and/or the regional location where the server was purchased, the server is configured with one of the following power supplies:

- HPE 550 W Power Supply (PN 730941-B21)

- HPE 800 W/900 W Gold AC Power Input Module (PN 744689-B21)
- HPE 900 W AC/240 V DC Gold Power Input Module (PN 775595-B21)

For more information about the compatibility between the power input module and RPS backplane types, see "Power input module and RPS backplane characteristics (on page 71)."

For more information about the power supply features, specifications, and compatibility, see the Hewlett Packard Enterprise website (<http://www.hpe.com/servers/powersupplies>).

 **CAUTION:** Check the system and power supply input ratings before powering up the server.

Hot-plug power supply calculations

For hot-plug power supply specifications and calculators to determine electrical and heat loading for the server, see the Hewlett Packard Enterprise Power Advisor website (<http://www.hpe.com/info/poweradvisor/online>).

Support and other resources

Accessing Hewlett Packard Enterprise Support

- For live assistance, go to the Contact Hewlett Packard Enterprise Worldwide website (<http://www.hpe.com/assistance>).
- To access documentation and support services, go to the Hewlett Packard Enterprise Support Center website (<http://www.hpe.com/support/hpesc>).

Information to collect

- Technical support registration number (if applicable)
- Product name, model or version, and serial number
- Operating system name and version
- Firmware version
- Error messages
- Product-specific reports and logs
- Add-on products or components
- Third-party products or components

Accessing updates

- Some software products provide a mechanism for accessing software updates through the product interface. Review your product documentation to identify the recommended software update method.
- To download product updates, go to either of the following:
 - Hewlett Packard Enterprise Support Center **Get connected with updates** page (<http://www.hpe.com/support/e-updates>)
 - Software Depot website (<http://www.hpe.com/support/softwaredepot>)
- To view and update your entitlements, and to link your contracts and warranties with your profile, go to the Hewlett Packard Enterprise Support Center **More Information on Access to Support Materials** page (<http://www.hpe.com/support/AccessToSupportMaterials>).



IMPORTANT: Access to some updates might require product entitlement when accessed through the Hewlett Packard Enterprise Support Center. You must have an HP Passport set up with relevant entitlements.

Websites

- Hewlett Packard Enterprise Information Library (<http://www.hpe.com/info/enterprise/docs>)
- Hewlett Packard Enterprise Support Center (<http://www.hpe.com/support/hpesc>)
- Contact Hewlett Packard Enterprise Worldwide (<http://www.hpe.com/assistance>)

- Subscription Service/Support Alerts (<http://www.hpe.com/support/e-updates>)
- Software Depot (<http://www.hpe.com/support/softwaredepot>)
- Customer Self Repair (<http://www.hpe.com/support/selfrepair>)
- Insight Remote Support (<http://www.hpe.com/info/insightremotesupport/docs>)
- Serviceguard Solutions for HP-UX (<http://www.hpe.com/info/hpux-serviceguard-docs>)
- Single Point of Connectivity Knowledge (SPOCK) Storage compatibility matrix (<http://www.hpe.com/storage/spock>)
- Storage white papers and analyst reports (<http://www.hpe.com/storage/whitepapers>)

Customer Self Repair

Hewlett Packard Enterprise products are designed with many Customer Self Repair (CSR) parts to minimize repair time and allow for greater flexibility in performing defective parts replacement. If during the diagnosis period Hewlett Packard Enterprise (or Hewlett Packard Enterprise service providers or service partners) identifies that the repair can be accomplished by the use of a CSR part, Hewlett Packard Enterprise will ship that part directly to you for replacement. There are two categories of CSR parts:

- **Mandatory**—Parts for which customer self repair is mandatory. If you request Hewlett Packard Enterprise to replace these parts, you will be charged for the travel and labor costs of this service.
- **Optional**—Parts for which customer self repair is optional. These parts are also designed for customer self repair. If, however, you require that Hewlett Packard Enterprise replace them for you, there may or may not be additional charges, depending on the type of warranty service designated for your product.

NOTE: Some Hewlett Packard Enterprise parts are not designed for customer self repair. In order to satisfy the customer warranty, Hewlett Packard Enterprise requires that an authorized service provider replace the part. These parts are identified as "No" in the Illustrated Parts Catalog.

Based on availability and where geography permits, CSR parts will be shipped for next business day delivery. Same day or four-hour delivery may be offered at an additional charge where geography permits. If assistance is required, you can call the Hewlett Packard Enterprise Support Center and a technician will help you over the telephone. Hewlett Packard Enterprise specifies in the materials shipped with a replacement CSR part whether a defective part must be returned to Hewlett Packard Enterprise. In cases where it is required to return the defective part to Hewlett Packard Enterprise, you must ship the defective part back to Hewlett Packard Enterprise within a defined period of time, normally five (5) business days. The defective part must be returned with the associated documentation in the provided shipping material. Failure to return the defective part may result in Hewlett Packard Enterprise billing you for the replacement. With a customer self repair, Hewlett Packard Enterprise will pay all shipping and part return costs and determine the courier/carrier to be used.

For more information about the Hewlett Packard Enterprise CSR program, contact your local service provider. For the North American program, go to the Hewlett Packard Enterprise CSR website (<http://www.hpe.com/support/selfrepair>).

Réparation par le client (CSR)

Les produits Hewlett Packard Enterprise comportent de nombreuses pièces CSR (Customer Self Repair = réparation par le client) afin de minimiser les délais de réparation et faciliter le remplacement des pièces défectueuses. Si pendant la période de diagnostic, Hewlett Packard Enterprise (ou ses partenaires ou mainteneurs agréés) détermine que la réparation peut être effectuée à l'aide d'une pièce CSR, Hewlett Packard Enterprise vous l'envoie directement. Il existe deux catégories de pièces CSR :

- **Obligatoire**—Pièces pour lesquelles la réparation par le client est obligatoire. Si vous demandez à Hewlett Packard Enterprise de remplacer ces pièces, les coûts de déplacement et main d'œuvre du service vous seront facturés.
- **Facultatif**—Pièces pour lesquelles la réparation par le client est facultative. Ces pièces sont également conçues pour permettre au client d'effectuer lui-même la réparation. Toutefois, si vous demandez à Hewlett Packard Enterprise de remplacer ces pièces, l'intervention peut ou non vous être facturée, selon le type de garantie applicable à votre produit.

REMARQUE: Certaines pièces Hewlett Packard Enterprise ne sont pas conçues pour permettre au client d'effectuer lui-même la réparation. Pour que la garantie puisse s'appliquer, Hewlett Packard Enterprise exige que le remplacement de la pièce soit effectué par un Mainteneur Agréé. Ces pièces sont identifiées par la mention "Non" dans le Catalogue illustré.

Les pièces CSR sont livrées le jour ouvré suivant, dans la limite des stocks disponibles et selon votre situation géographique. Si votre situation géographique le permet et que vous demandez une livraison le jour même ou dans les 4 heures, celle-ci vous sera facturée. Pour toute assistance, appelez le Centre d'assistance Hewlett Packard Enterprise pour qu'un technicien vous aide au téléphone. Dans les documents envoyés avec la pièce de rechange CSR, Hewlett Packard Enterprise précise s'il est nécessaire de lui retourner la pièce défectueuse. Si c'est le cas, vous devez le faire dans le délai indiqué, généralement cinq (5) jours ouvrés. La pièce et sa documentation doivent être retournées dans l'emballage fourni. Si vous ne retournez pas la pièce défectueuse, Hewlett Packard Enterprise se réserve le droit de vous facturer les coûts de remplacement. Dans le cas d'une pièce CSR, Hewlett Packard Enterprise supporte l'ensemble des frais d'expédition et de retour, et détermine la société de courses ou le transporteur à utiliser.

Pour plus d'informations sur le programme CSR de Hewlett Packard Enterprise, contactez votre Mainteneur Agréé local. Pour plus d'informations sur ce programme en Amérique du Nord, consultez le site Web Hewlett Packard Enterprise (<http://www.hpe.com/support/selfrepair>).

Riparazione da parte del cliente

Per abbreviare i tempi di riparazione e garantire una maggiore flessibilità nella sostituzione di parti difettose, i prodotti Hewlett Packard Enterprise sono realizzati con numerosi componenti che possono essere riparati direttamente dal cliente (CSR, Customer Self Repair). Se in fase di diagnostica Hewlett Packard Enterprise (o un centro di servizi o di assistenza Hewlett Packard Enterprise) identifica il guasto come riparabile mediante un ricambio CSR, Hewlett Packard Enterprise lo spedisce direttamente al cliente per la sostituzione. Vi sono due categorie di parti CSR:

- **Obbligatorie**—Parti che devono essere necessariamente riparate dal cliente. Se il cliente ne affida la riparazione ad Hewlett Packard Enterprise, deve sostenere le spese di spedizione e di manodopera per il servizio.
- **Opzionali**—Parti la cui riparazione da parte del cliente è facoltativa. Si tratta comunque di componenti progettati per questo scopo. Se tuttavia il cliente ne richiede la sostituzione ad Hewlett Packard Enterprise, potrebbe dover sostenere spese aggiuntive a seconda del tipo di garanzia previsto per il prodotto.

NOTA: alcuni componenti Hewlett Packard Enterprise non sono progettati per la riparazione da parte del cliente. Per rispettare la garanzia, Hewlett Packard Enterprise richiede che queste parti siano sostituite da un centro di assistenza autorizzato. Tali parti sono identificate da un "No" nel Catalogo illustrato dei componenti.

In base alla disponibilità e alla località geografica, le parti CSR vengono spedite con consegna entro il giorno lavorativo seguente. La consegna nel giorno stesso o entro quattro ore è offerta con un supplemento di costo solo in alcune zone. In caso di necessità si può richiedere l'assistenza telefonica di un addetto del centro di supporto tecnico Hewlett Packard Enterprise. Nel materiale fornito con una parte di ricambio CSR, Hewlett Packard Enterprise specifica se il cliente deve restituire dei componenti. Qualora sia richiesta la resa ad Hewlett Packard Enterprise del componente difettoso, lo si deve spedire ad Hewlett Packard Enterprise entro un determinato periodo di tempo, generalmente cinque (5) giorni lavorativi. Il componente difettoso deve essere restituito con la documentazione associata nell'imballo di

spedizione fornito. La mancata restituzione del componente può comportare la fatturazione del ricambio da parte di Hewlett Packard Enterprise. Nel caso di riparazione da parte del cliente, Hewlett Packard Enterprise sostiene tutte le spese di spedizione e resa e sceglie il corriere/vettore da utilizzare.

Per ulteriori informazioni sul programma CSR di Hewlett Packard Enterprise, contattare il centro di assistenza di zona. Per il programma in Nord America fare riferimento al sito Web (<http://www.hpe.com/support/selfrepair>).

Customer Self Repair

Hewlett Packard Enterprise Produkte enthalten viele CSR-Teile (Customer Self Repair), um Reparaturzeiten zu minimieren und höhere Flexibilität beim Austausch defekter Bauteile zu ermöglichen. Wenn Hewlett Packard Enterprise (oder ein Hewlett Packard Enterprise Servicepartner) bei der Diagnose feststellt, dass das Produkt mithilfe eines CSR-Teils repariert werden kann, sendet Ihnen Hewlett Packard Enterprise dieses Bauteil zum Austausch direkt zu. CSR-Teile werden in zwei Kategorien unterteilt:

- **Zwingend**—Teile, für die das Customer Self Repair-Verfahren zwingend vorgegeben ist. Wenn Sie den Austausch dieser Teile von Hewlett Packard Enterprise vornehmen lassen, werden Ihnen die Anfahrt- und Arbeitskosten für diesen Service berechnet.
- **Optional**—Teile, für die das Customer Self Repair-Verfahren optional ist. Diese Teile sind auch für Customer Self Repair ausgelegt. Wenn Sie jedoch den Austausch dieser Teile von Hewlett Packard Enterprise vornehmen lassen möchten, können bei diesem Service je nach den für Ihr Produkt vorgesehenen Garantiebedingungen zusätzliche Kosten anfallen.

HINWEIS: Einige Hewlett Packard Enterprise Teile sind nicht für Customer Self Repair ausgelegt. Um den Garantieanspruch des Kunden zu erfüllen, muss das Teil von einem Hewlett Packard Enterprise Servicepartner ersetzt werden. Im illustrierten Teilekatalog sind diese Teile mit „No“ bzw. „Nein“ gekennzeichnet.

CSR-Teile werden abhängig von der Verfügbarkeit und vom Lieferziel am folgenden Geschäftstag geliefert. Für bestimmte Standorte ist eine Lieferung am selben Tag oder innerhalb von vier Stunden gegen einen Aufpreis verfügbar. Wenn Sie Hilfe benötigen, können Sie das Hewlett Packard Enterprise Support Center anrufen und sich von einem Mitarbeiter per Telefon helfen lassen. Den Materialien von Hewlett Packard Enterprise, die mit einem CSR-Ersatzteil geliefert werden, können Sie entnehmen, ob das defekte Teil an Hewlett Packard Enterprise zurückgeschickt werden muss. Wenn es erforderlich ist, das defekte Teil an Hewlett Packard Enterprise zurückzuschicken, müssen Sie dies innerhalb eines vorgegebenen Zeitraums tun, in der Regel innerhalb von fünf (5) Geschäftstagen. Das defekte Teil muss mit der zugehörigen Dokumentation in der Verpackung zurückgeschickt werden, die im Lieferumfang enthalten ist. Wenn Sie das defekte Teil nicht zurückschicken, kann Hewlett Packard Enterprise Ihnen das Ersatzteil in Rechnung stellen. Im Falle von Customer Self Repair kommt Hewlett Packard Enterprise für alle Kosten für die Lieferung und Rücksendung auf und bestimmt den Kurier-/Frachtdienst.

Weitere Informationen über das Hewlett Packard Enterprise Customer Self Repair Programm erhalten Sie von Ihrem Servicepartner vor Ort. Informationen über das CSR-Programm in Nordamerika finden Sie auf der Hewlett Packard Enterprise Website unter (<http://www.hpe.com/support/selfrepair>).

Reparaciones del propio cliente

Los productos de Hewlett Packard Enterprise incluyen muchos componentes que el propio usuario puede reemplazar (Customer Self Repair, CSR) para minimizar el tiempo de reparación y ofrecer una mayor flexibilidad a la hora de realizar sustituciones de componentes defectuosos. Si, durante la fase de diagnóstico, Hewlett Packard Enterprise (o los proveedores o socios de servicio de Hewlett Packard Enterprise) identifica que una reparación puede llevarse a cabo mediante el uso de un componente CSR, Hewlett Packard Enterprise le enviará dicho componente directamente para que realice su sustitución. Los componentes CSR se clasifican en dos categorías:

- **Obligatorio**—componentes cuya reparación por parte del usuario es obligatoria. Si solicita a Hewlett Packard Enterprise que realice la sustitución de estos componentes, tendrá que hacerse cargo de los gastos de desplazamiento y de mano de obra de dicho servicio.
- **Opcional**—componentes cuya reparación por parte del usuario es opcional. Estos componentes también están diseñados para que puedan ser reparados por el usuario. Sin embargo, si precisa que Hewlett Packard Enterprise realice su sustitución, puede o no conllevar costes adicionales, dependiendo del tipo de servicio de garantía correspondiente al producto.

NOTA: Algunos componentes de Hewlett Packard Enterprise no están diseñados para que puedan ser reparados por el usuario. Para que el usuario haga valer su garantía, Hewlett Packard Enterprise pone como condición que un proveedor de servicios autorizado realice la sustitución de estos componentes. Dichos componentes se identifican con la palabra "No" en el catálogo ilustrado de componentes.

Según la disponibilidad y la situación geográfica, los componentes CSR se enviarán para que lleguen a su destino al siguiente día laborable. Si la situación geográfica lo permite, se puede solicitar la entrega en el mismo día o en cuatro horas con un coste adicional. Si precisa asistencia técnica, puede llamar al Centro de asistencia técnica de Hewlett Packard Enterprise y recibirá ayuda telefónica por parte de un técnico. Con el envío de materiales para la sustitución de componentes CSR, Hewlett Packard Enterprise especificará si los componentes defectuosos deberán devolverse a Hewlett Packard Enterprise. En aquellos casos en los que sea necesario devolver algún componente a Hewlett Packard Enterprise, deberá hacerlo en el periodo de tiempo especificado, normalmente cinco días laborables. Los componentes defectuosos deberán devolverse con toda la documentación relacionada y con el embalaje de envío. Si no enviara el componente defectuoso requerido, Hewlett Packard Enterprise podrá cobrarle por el de sustitución. En el caso de todas sustituciones que lleve a cabo el cliente, Hewlett Packard Enterprise se hará cargo de todos los gastos de envío y devolución de componentes y escogerá la empresa de transporte que se utilice para dicho servicio.

Para obtener más información acerca del programa de Reparaciones del propio cliente de Hewlett Packard Enterprise, póngase en contacto con su proveedor de servicios local. Si está interesado en el programa para Norteamérica, visite la página web de Hewlett Packard Enterprise CSR (<http://www.hpe.com/support/selfrepair>).

Customer Self Repair

Veel onderdelen in Hewlett Packard Enterprise producten zijn door de klant zelf te repareren, waardoor de reparatieduur tot een minimum beperkt kan blijven en de flexibiliteit in het vervangen van defecte onderdelen groter is. Deze onderdelen worden CSR-onderdelen (Customer Self Repair) genoemd. Als Hewlett Packard Enterprise (of een Hewlett Packard Enterprise Service Partner) bij de diagnose vaststelt dat de reparatie kan worden uitgevoerd met een CSR-onderdeel, verzendt Hewlett Packard Enterprise dat onderdeel rechtstreeks naar u, zodat u het defecte onderdeel daarmee kunt vervangen. Er zijn twee categorieën CSR-onderdelen:

- **Verplicht**—Onderdelen waarvoor reparatie door de klant verplicht is. Als u Hewlett Packard Enterprise verzoekt deze onderdelen voor u te vervangen, worden u voor deze service reiskosten en arbeidsloon in rekening gebracht.
- **Optioneel**—Onderdelen waarvoor reparatie door de klant optioneel is. Ook deze onderdelen zijn ontworpen voor reparatie door de klant. Als u echter Hewlett Packard Enterprise verzoekt deze onderdelen voor u te vervangen, kunnen daarvoor extra kosten in rekening worden gebracht, afhankelijk van het type garantieservice voor het product.

OPMERKING: Sommige Hewlett Packard Enterprise onderdelen zijn niet ontwikkeld voor reparatie door de klant. In verband met de garantievooraarden moet het onderdeel door een geautoriseerde Service Partner worden vervangen. Deze onderdelen worden in de geïllustreerde onderdelencatalogus aangemerkt met "Nee".

Afhankelijk van de leverbaarheid en de locatie worden CSR-onderdelen verzonden voor levering op de eerstvolgende werkdag. Levering op dezelfde dag of binnen vier uur kan tegen meerkosten worden aangeboden, indien dit mogelijk is gezien de locatie. Indien assistentie is gewenst, belt u het Hewlett Packard Enterprise Support Center om via de telefoon ondersteuning van een technicus te ontvangen.

Hewlett Packard Enterprise vermeldt in de documentatie bij het vervangende CSR-onderdeel of het defecte onderdeel aan Hewlett Packard Enterprise moet worden geretourneerd. Als het defecte onderdeel aan Hewlett Packard Enterprise moet worden teruggezonden, moet u het defecte onderdeel binnen een bepaalde periode, gewoonlijk vijf (5) werkdagen, retourneren aan Hewlett Packard Enterprise. Het defecte onderdeel moet met de bijbehorende documentatie worden geretourneerd in het meegeleverde verpakkingsmateriaal. Als u het defecte onderdeel niet terugzendt, kan Hewlett Packard Enterprise u voor het vervangende onderdeel kosten in rekening brengen. Bij reparatie door de klant betaalt Hewlett Packard Enterprise alle verzendkosten voor het vervangende en geretourneerde onderdeel en kiest Hewlett Packard Enterprise zelf welke koerier/transportonderneming hiervoor wordt gebruikt.

Neem contact op met een Service Partner voor meer informatie over het Customer Self Repair programma van Hewlett Packard Enterprise. Informatie over Service Partners vindt u op de Hewlett Packard Enterprise website (<http://www.hpe.com/support/selfrepair>).

Reparo feito pelo cliente

Os produtos da Hewlett Packard Enterprise são projetados com muitas peças para reparo feito pelo cliente (CSR) de modo a minimizar o tempo de reparo e permitir maior flexibilidade na substituição de peças com defeito. Se, durante o período de diagnóstico, a Hewlett Packard Enterprise (ou fornecedores/parceiros da Hewlett Packard Enterprise) concluir que o reparo pode ser efetuado pelo uso de uma peça CSR, a Hewlett Packard Enterprise enviará a peça diretamente ao cliente. Há duas categorias de peças CSR:

- **Obrigatória**—Peças cujo reparo feito pelo cliente é obrigatório. Se desejar que a Hewlett Packard Enterprise substitua essas peças, serão cobradas as despesas de transporte e mão-de-obra do serviço.
- **Opcional**—Peças cujo reparo feito pelo cliente é opcional. Essas peças também são projetadas para o reparo feito pelo cliente. No entanto, se desejar que a Hewlett Packard Enterprise as substitua, pode haver ou não a cobrança de taxa adicional, dependendo do tipo de serviço de garantia destinado ao produto.

OBSERVAÇÃO: Algumas peças da Hewlett Packard Enterprise não são projetadas para o reparo feito pelo cliente. A fim de cumprir a garantia do cliente, a Hewlett Packard Enterprise exige que um técnico autorizado substitua a peça. Essas peças estão identificadas com a marca "No" (Não), no catálogo de peças ilustrado.

Conforme a disponibilidade e o local geográfico, as peças CSR serão enviadas no primeiro dia útil após o pedido. Onde as condições geográficas permitirem, a entrega no mesmo dia ou em quatro horas pode ser feita mediante uma taxa adicional. Se precisar de auxílio, entre em contato com o Centro de suporte técnico da Hewlett Packard Enterprise para que um técnico o ajude por telefone. A Hewlett Packard Enterprise especifica nos materiais fornecidos com a peça CSR de reposição se a peça com defeito deve ser devolvida à Hewlett Packard Enterprise. Nos casos em que isso for necessário, é preciso enviar a peça com defeito à Hewlett Packard Enterprise, você deverá enviar a peça com defeito de volta para a Hewlett Packard Enterprise dentro do período de tempo definido, normalmente em 5 (cinco) dias úteis. A peça com defeito deve ser enviada com a documentação correspondente no material de transporte fornecido. Caso não o faça, a Hewlett Packard Enterprise poderá cobrar a reposição. Para as peças de reparo feito pelo cliente, a Hewlett Packard Enterprise paga todas as despesas de transporte e de devolução da peça e determina a transportadora/serviço postal a ser utilizado.

Para obter mais informações sobre o programa de reparo feito pelo cliente da Hewlett Packard Enterprise, entre em contato com o fornecedor de serviços local. Para o programa norte-americano, visite o site da Hewlett Packard Enterprise (<http://www.hpe.com/support/selfrepair>).

カスタマーセルフリペア

修理時間を短縮し、故障部品の交換における高い柔軟性を確保するために、Hewlett Packard Enterprise製品には多数のカスタマーセルフリペア（CSR）部品があります。診断の際に、CSR部品を使用すれば修理ができるとHewlett Packard Enterprise（Hewlett Packard EnterpriseまたはHewlett Packard Enterprise正規保守代理店）が判断した場合、Hewlett Packard Enterpriseはその部品を直接、お客様に発送し、お客様に交換していただきます。CSR部品には以下の2種類があります。

- **必須** - カスタマーセルフリペアが必須の部品。当該部品について、もしもお客様がHewlett Packard Enterpriseに交換作業を依頼される場合には、その修理サービスに関する交通費および人件費がお客様に請求されます。
- **任意** - カスタマーセルフリペアが任意である部品。この部品もカスタマーセルフリペア用です。当該部品について、もしもお客様がHewlett Packard Enterpriseに交換作業を依頼される場合には、お買い上げの製品に適用される保証サービス内容の範囲内においては、別途費用を負担していただくことなく保証サービスを受けることができます。

注： Hewlett Packard Enterprise製品の一部の部品は、カスタマーセルフリペアの対象外です。製品の保証を継続するためには、Hewlett Packard EnterpriseまたはHewlett Packard Enterprise正規保守代理店による交換作業が必須となります。部品カタログには、当該部品がカスタマーセルフリペア除外品である旨が記載されています。

部品供給が可能な場合、地域によっては、CSR部品を翌営業日に届くように発送します。また、地域によっては、追加費用を負担いただくことにより同日または4時間以内に届くように発送することも可能な場合があります。サポートが必要なときは、Hewlett Packard Enterpriseの修理受付窓口に電話していただければ、技術者が電話でアドバイスします。交換用のCSR部品または同梱物には、故障部品をHewlett Packard Enterpriseに返送する必要があるかどうかが表示されています。故障部品をHewlett Packard Enterpriseに返送する必要がある場合は、指定期限内（通常は5営業日以内）に故障部品をHewlett Packard Enterpriseに返送してください。故障部品を返送する場合は、届いた時の梱包箱に関連書類とともに入れてください。故障部品を返送しない場合、Hewlett Packard Enterpriseから部品費用が請求されます。カスタマーセルフリペアの際には、Hewlett Packard Enterpriseは送料および部品返送料を全額負担し、使用する宅配便会社や運送会社を指定します。

客户自行维修

Hewlett Packard Enterprise 产品提供许多客户自行维修 (CSR) 部件，以尽可能缩短维修时间和在更换缺陷部件方面提供更大的灵活性。如果在诊断期间 Hewlett Packard Enterprise (或 Hewlett Packard Enterprise 服务提供商或服务合作伙伴) 确定可以通过使用 CSR 部件完成维修，Hewlett Packard Enterprise 将直接把该部件发送给您进行更换。有两类 CSR 部件：

- **强制性的** — 要求客户必须自行维修的部件。如果您请求 Hewlett Packard Enterprise 更换这些部件，则必须为该服务支付差旅费和人工费用。
- **可选的** — 客户可以选择是否自行维修的部件。这些部件也是为客户自行维修设计的。不过，如果您要求 Hewlett Packard Enterprise 为您更换这些部件，则根据为您的产品指定的保修服务类型，Hewlett Packard Enterprise 可能收取或不再收取任何附加费用。

注：某些 Hewlett Packard Enterprise 部件的设计并未考虑客户自行维修。为了满足客户保修的需要，Hewlett Packard Enterprise 要求授权服务提供商更换相关部件。这些部件在部件图解目录中标记为“否”。

CSR 部件将在下一个工作日发运（取决于备货情况和允许的地理范围）。在允许的地理范围内，可在当天或四小时内发运，但要收取额外费用。如果需要帮助，您可以致电 Hewlett Packard Enterprise 技术支持中心，将会有技术人员通过电话为您提供帮助。Hewlett Packard Enterprise 会在随更换的 CSR 部件发运的材料中指明是否必须将有缺陷的部件返还给 Hewlett Packard Enterprise。如果要求您将缺陷的部件返还给 Hewlett Packard Enterprise，那么您必须在规定的期限内（通常是五 (5) 个工作日）将缺陷部件发给 Hewlett Packard Enterprise。有缺陷的部件必须随所提供的发运材料中的相关文件一起返还。如果未能送还有缺陷的部件，Hewlett Packard Enterprise 可能会要求您支付更换费用。客户自行维修时，Hewlett Packard Enterprise 将承担所有相关运输和部件返回费用，并指定快递员/承运商。

有关 Hewlett Packard Enterprise 客户自行维修计划的详细信息，请与您当地的服务提供商联系。有关北美地区的计划，请访问 Hewlett Packard Enterprise 网站 (<http://www.hpe.com/support/selfrepair>)。

客戶自行維修

Hewlett Packard Enterprise 產品設計了許多「客戶自行維修」(CSR) 的零件以減少維修時間，並且使得更換瑕疵零件時能有更大的彈性。如果在診斷期間，Hewlett Packard Enterprise (或 Hewlett Packard Enterprise 服務供應商或維修夥伴) 辨認出此項維修工作可以藉由使用 CSR 零件來完成，則 Hewlett Packard Enterprise 將直接寄送該零件給您作更換。CSR 零件分為兩種類別：

- **強制的** — 客戶自行維修所使用的零件是強制的。如果您要求 Hewlett Packard Enterprise 更換這些零件，Hewlett Packard Enterprise 將會向您收取此服務所需的外出費用與勞動成本。
- **選購的** — 客戶自行維修所使用的零件是選購的。這些零件也設計用於客戶自行維修之用。不過，如果您要求 Hewlett Packard Enterprise 為您更換，則可能需要也可能不需要負擔額外的費用，端視針對此產品指定的保固服務類型而定。

備註：某些 Hewlett Packard Enterprise 零件沒有消費者可自行維修的設計。為符合客戶保固，Hewlett Packard Enterprise 需要授權的服務供應商更換零件。這些零件在圖示的零件目錄中，被標示為「否」。

基於材料取得及環境允許的情況下，CSR 零件將於下一個工作日以快遞寄送。在環境的允許下當天或四小時內送達，則可能需要額外的費用。若您需要協助，可致電 Hewlett Packard Enterprise 支援中心，會有一位技術人員透過電話來協助您。不論損壞的零件是否必須退回，Hewlett Packard Enterprise 皆會在與 CSR 替換零件一起運送的材料中註明。若要將損壞的零件退回 Hewlett Packard Enterprise，您必須在指定的一段時間內 (通常為五 (5) 個工作天)，將損壞的零件寄回 Hewlett Packard Enterprise。損壞的零件必須與寄送資料中隨附的相關技術文件一併退還。如果無法退還損壞的零件，Hewlett Packard Enterprise 可能要向您收取替換費用。針對客戶自行維修情形，Hewlett Packard Enterprise 將負責所有運費及零件退還費用，並指定使用何家快遞/貨運公司。

如需 Hewlett Packard Enterprise 的 CSR 方案詳細資訊，請連絡您當地的服務供應商。至於北美方案，請參閱 Hewlett Packard Enterprise 的 CSR 網站 [selfrepair](http://www.hpe.com/support/selfrepair) (<http://www.hpe.com/support/selfrepair>)。

고객 셀프 수리

Hewlett Packard Enterprise 제품은 수리 시간을 최소화하고 결함이 있는 부품 교체 시 더욱 용통성을 발휘할 수 있도록 하기 위해 고객 셀프 수리(CSR) 부품을 다량 사용하여 설계되었습니다. 진단 기간 동안 Hewlett Packard Enterprise(또는 Hewlett Packard Enterprise 서비스 공급업체 또는 서비스 협력업체)에서 CSR 부품을 사용하여 수리가 가능하다고 판단되면 Hewlett Packard Enterprise는 해당 부품을 바로 사용자에게 보내어 사용자가 교체할 수 있도록 합니다. CSR 부품에는 두 가지 종류가 있습니다.

- 필수 - 고객 셀프 수리가 의무 사항인 필수 부품. 사용자가 Hewlett Packard Enterprise에 이 부품의 교체를 요청할 경우 이 서비스에 대한 출장비 및 작업비가 청구됩니다.
- 선택 사항 - 고객 셀프 수리가 선택 사항인 부품. 이 부품들도 고객 셀프 수리가 가능하도록 설계되었습니다. 하지만 사용자가 Hewlett Packard Enterprise에 이 부품의 교체를 요청할 경우 사용자가 구입한 제품에 해당하는 보증 서비스 유형에 따라 추가 비용 없이 교체가 가능할 수 있습니다.

참고: 일부 Hewlett Packard Enterprise 부품은 고객 셀프 수리가 불가능하도록 설계되었습니다. Hewlett Packard Enterprise는 만족스러운 고객 보증을 위해 공인 서비스 제공업체를 통해 부품을 교체하도록 하고 있습니다. 이러한 부품들은 Illustrated Parts Catalog에 “No”라고 표시되어 있습니다.

CSR 부품은 재고 상태와 지리적 조건이 허용하는 경우 다음 영업일 납품이 가능하도록 배송이 이루어집니다. 지리적 조건이 허용하는 경우 추가 비용이 청구되는 조건으로 당일 또는 4시간 배송이 가능할 수도 있습니다. 도움이 필요하시면 Hewlett Packard Enterprise Support Center로 전화하십시오. 전문 기술자가 전화로 도움을 줄 것입니다. Hewlett Packard Enterprise는 결함이 발생한 부품을 Hewlett Packard Enterprise로 반환해야 하는지 여부를 CSR 교체 부품과 함께 배송된 자료에 지정합니다. 결함이 발생한 부품을 Hewlett Packard Enterprise로 반환해야 하는 경우에는 지정된 기간 내(통상 영업일 기준 5일)에 Hewlett Packard Enterprise로 반환해야 합니다. 이때 결함이 발생한 부품은 제공된 포장 재료에 넣어 관련 설명서와 함께 반환해야 합니다. 결함이 발생한 부품을 반환하지 않는 경우 Hewlett Packard Enterprise가 교체 부품에 대해 비용을 청구할 수 있습니다. 고객 셀프 수리의 경우, Hewlett Packard Enterprise는 모든 운송 및 부품 반환 비용을 부담하며 이용할 운송업체 및 택배 서비스를 결정합니다.

Hewlett Packard Enterprise CSR 프로그램에 대한 자세한 내용은 가까운 서비스 제공업체에 문의하십시오. 북미 지역의 프로그램에 대해서는 Hewlett Packard Enterprise CSR 웹사이트(<http://www.hpe.com/support/selfrepair>)를 참조하십시오.

Remote support

Remote support is available with supported devices as part of your warranty or contractual support agreement. It provides intelligent event diagnosis, and automatic, secure submission of hardware event notifications to Hewlett Packard Enterprise, which will initiate a fast and accurate resolution based on your product's service level. Hewlett Packard Enterprise strongly recommends that you register your device for remote support.

For more information and device support details, go to the Insight Remote Support website (<http://www.hpe.com/info/insightremotesupport/docs>).

Acronyms and abbreviations

ABEND

abnormal end

ACU

Array Configuration Utility

AMP

Advanced Memory Protection

API

application program interface

ASHRAE

American Society of Heating, Refrigerating and Air-Conditioning Engineers

ASR

Automatic Server Recovery

BP

backplane

CAS

column address strobe

CSA

Canadian Standards Association

CSR

Customer Self Repair

DDR3

double data rate-3

DDR4

double data rate-4

DPC

DIMMs per channel

FAT

file allocation table

FBWC

flash-backed write cache

HBA

host bus adapter

HP SUM

HP Smart Update Manager

HPE SIM

HPE Systems Insight Manager

HPE SSA

HPE Smart Storage Administrator

IEC

International Electrotechnical Commission

iLO

Integrated Lights-Out

IML

Integrated Management Log

ISO

International Organization for Standardization

JSON

JavaScript Object Notation

LFF

large form factor

LOM

LAN on Motherboard

LRDIMM

load reduced dual in-line memory module

NMI

nonmaskable interrupt

NVRAM

nonvolatile memory

OA

Onboard Administrator

ODD

Optical Disk Drive

PCIe

Peripheral Component Interconnect Express

PDU

power distribution unit

POST

Power-On Self Test

PSU

power supply unit

RDIMM

registered dual in-line memory module

RDP

Rapid Deployment Pack

REST

representational state transfer

RoHS

Restriction of Hazardous Substances

RPS

redundant power supply

SAS

serial attached SCSI

SATA

serial ATA

SD

Secure Digital

SFF

small form factor

SIM

Systems Insight Manager

SPP

Service Pack for ProLiant

SSD

solid-state drive

STD

standard (DIMM voltage)

TMRA

recommended ambient operating temperature

TPM

Trusted Platform Module

UEFI

Unified Extensible Firmware Interface

UID

unit identification

USB

universal serial bus

VC

Virtual Connect

VCA

Version Control Agent

VCRM

Version Control Repository Manager

xHCI

Extensible Host Controller Interface

Documentation feedback

Hewlett Packard Enterprise is committed to providing documentation that meets your needs. To help us improve the documentation, send any errors, suggestions, or comments to Documentation Feedback ([**mailto:docsfeedback@hpe.com**](mailto:docsfeedback@hpe.com)). When submitting your feedback, include the document title, part number, edition, and publication date located on the front cover of the document. For online help content, include the product name, product version, help edition, and publication date located on the legal notices page.

Index

A

- access panel, install 19
- Active Health System 89, 90
- Advanced ECC memory 52, 53
- Advanced ECC population guidelines 53
- Advanced ECC support 52
- air baffle, installation 20
- air baffle, removing 19
- airflow requirements 26, 27
- ambient temperature 27, 108
- ambient temperature sensor cable 88
- authorized reseller 107, 110
- authorized technician 111
- Automatic Server Recovery (ASR) 97

B

- Belarus Kazakhstan Russia marking 105
- bezel, installing 36
- BIOS upgrade 89
- boot options 35, 93, 94, 96

C

- cable management 33
- cable management arm 17
- cabling 79
- cabling, battery pack 86
- cabling, drive 79, 80
- cabling, FBWC 84
- cabling, optical drive 88
- cabling, redundant power supply 87
- Care Pack 101, 110
- cautions 28, 107
- change control and proactive notification 101
- components, front panel 6
- components, system board 10
- configuration of system 89
- contacting Hewlett Packard Enterprise 110
- crash dump analysis 12
- customer self repair (CSR) 111

D

- default settings 52
- diagnosing problems 102
- diagnostic tools 89, 92, 94, 96, 97
- dimensions and weight 108
- DIMM identification 51
- DIMM installation guidelines 51

- DIMMs, installing 54
- DIMMs, single- dual-, and quad-rank 51
- documentation feedback 123
- drive cabling 43, 79
- drive LEDs 13
- drive numbering 12
- drivers 100
- drives 13
- drives, determining status of 12, 13
- drives, installation guidelines 37
- drives, installing 37, 38

E

- electrical grounding requirements 28
- electrostatic discharge 107
- embedded UEFI diagnostics 96
- embedded UEFI shell 95
- enabling the Trusted Platform Module 75, 77
- environmental requirements 26
- environmental specifications 108
- Erase Utility 89, 92
- error messages 102
- EuroAsian Economic Commission 105
- expansion board options 39
- external USB functionality 97

F

- fan connectors 10
- fan modules, installation 47
- FBWC cabling 84
- firmware 98, 100
- flexible boot control 94
- Foundation Care Services 101
- front I/O cabling 88
- front panel components 6
- front panel LEDs 7, 8

G

- grounding methods 107
- grounding requirements 28, 107

H

- hardware options installation 36
- health driver 97
- help resources 110
- Hewlett Packard Enterprise contact information 110
- Hewlett Packard Enterprise Support Center 101

Hewlett Packard Enterprise Technical Support 101, 110, 118
Hewlett Packard Enterprise website 110
hot-plug drive, installing 38
hot-swap fan 47
HP Smart Update Manager overview 89, 93
HP Trusted Platform Module option 75
HPE Collaborative Support 101
HPE Dual 8Gb microSD USB device 69
HPE Insight Diagnostics 91, 92
HPE Insight Diagnostics survey functionality 92
HPE Insight Remote Support software 101
HPE Proactive Care 101
HPE SmartMemory 50
HPE SSA (HPE Smart Storage Administrator) 89, 96
HPE support services 26, 101, 110
HPE Systems Insight Manager (SIM) 91, 92
HPE UEFI System Utilities 93, 94
humidity 108

I

Insight Diagnostics 92, 98
installation services 26, 30
installing hardware 30, 36
installing server into a rack 30, 33
integrated array controller 43
Integrated Lights-Out (iLO) 89, 91
Integrated Management Log (IML) 91
Intelligent Provisioning 89, 91, 92, 93, 94

L

LEDs, drive 13
LEDs, front panel 13
LEDs, power fault 8
legacy USB support 97

M

M.2 SSD cabling 82
M.2 SSD enablement option 67
maintenance guidelines 98
mechanical specifications 108
memory configurations 52, 53
memory dump 12
memory options 49
memory subsystem architecture 51
memory, Advanced ECC 52
memory, configuration requirements 52, 53
memory, configuring 52, 53
memory, online spare 53, 54
microSD card slot 10
Mini-SAS cabling 79

N

NMI functionality 12

NMI header 12
non-hot-plug drives, installing 37
non-hot-plug power supply cabling 87
notification actions 101

O

online spare memory 53, 54
online spare population guidelines 53, 54
operating environment, recommended 26
operating system crash 12, 97
operating system installation 34, 101
operating systems supported 92, 100, 101
optical drive cabling 88
optimum environment 26
options installation 30, 36

P

PCI riser board slot definitions 9
PCI riser cage, installing 23
population guidelines, online spare 54
power calculator 27, 109
power distribution unit (PDU) 28
power fault 8
power requirements 27
power supply 109
power supply cabling 87
power supply specifications 108
powering down 15
powering up 15
proactive notification 101
problem diagnosis 102
processor 56
Product ID 96

Q

QuickSpecs 39, 43, 51, 89

R

rack rail hook-and-loop strap 33
rack warnings 29
RAID configuration 96
rear panel LEDs 9
recommended ambient operating temperature (TMRA) 27
recovery key 77
redundant fan 46
redundant power supply 70, 108
redundant ROM 97
re-entering the server serial number 96
registering the server 35
regulatory compliance information 105
removing the security bezel 18
requirements, airflow 26, 28
requirements, electrical grounding 28
requirements, environmental 26, 108

- requirements, power 27
- requirements, site 27
- requirements, space 26
- requirements, temperature 27
- RESTful API 91, 96
- RoHS 106

S

- safety considerations 98, 105, 107
- safety information 98, 105
- scripted installation 93
- scripting toolkit 89, 93
- secure boot configuration 95
- security bezel 36
- security bezel, removing 18
- serial number 96
- Server mode 89
- server options, installing 36
- server setup 26, 35, 98
- server specifications 108
- server warnings and cautions 28, 29
- Service Pack for ProLiant 89, 92, 93
- Service Packs 93
- site requirements 27
- Smart Storage Battery cabling 86
- space and airflow requirements 26
- specifications, environmental 108
- specifications, power supply 108
- specifications, server 108
- SPP 92, 93
- static electricity 107
- storage cabling, four-bay drive 80
- storage controller 39, 79
- supported operating systems 100, 101
- system board components 10
- system configuration settings 97, 98
- System Erase Utility 92
- system maintenance switch 11
- system, keeping current 98

T

- technical support 101, 110
- technology services 101
- temperature requirements 27, 108
- TMRA (recommended ambient operating temperature) 27
- TPM, connector 10
- troubleshooting resources 6, 79, 102, 108
- Trusted Platform Module (TPM) 75, 77
- Turkey RoHS material content declaration 106

U

- Ukraine RoHS material content declaration 106
- uninterruptible power supply (UPS) 27
- updating the system ROM 97, 98, 99
- USB support 97

- utilities 89, 93, 94, 96
- utilities, deployment 89, 93

V

- ventilation 26
- Version Control Agent (VCA) 100
- Version Control Repository Manager (VCRM) 100
- Virtualization option 101

W

- warnings 28, 29
- warranty information 105
- website, Hewlett Packard Enterprise 110
- weight 108