



# **HPE ProLiant DL360 Gen10 Server User Guide**

Part Number: 30-11A09754-401h  
Published: October 2024  
Edition: 16

# HPE ProLiant DL360 Gen10 Server User Guide

## Abstract

This document is for the person who installs, administers, and troubleshoots servers and storage systems. Hewlett Packard Enterprise assumes you are qualified in the servicing of computer equipment and trained in recognizing hazards in products with hazardous energy levels.

Part Number: 30-11A09754-401h

Published: October 2024

Edition: 16

© Copyright 2018-2024 Hewlett Packard Enterprise Development LP

## Notices

The information contained herein is subject to change without notice. The only warranties for Hewlett Packard Enterprise products and services are set forth in the express warranty statements accompanying such products and services. Nothing herein should be construed as constituting an additional warranty. Hewlett Packard Enterprise shall not be liable for technical or editorial errors or omissions contained herein.

Confidential computer software. Valid license from Hewlett Packard Enterprise required for possession, use, or copying. Consistent with FAR 12.211 and 12.212, Commercial Computer Software, Computer Software Documentation, and Technical Data for Commercial Items are licensed to the U.S. Government under vendor's standard commercial license.

Links to third-party websites take you outside the Hewlett Packard Enterprise website. Hewlett Packard Enterprise has no control over and is not responsible for information outside the Hewlett Packard Enterprise website.

## Acknowledgments

Intel® and Xeon® are trademarks of Intel Corporation in the United States and other countries.

Ampere®, Altra®, and the A®, and Ampere® logos are registered trademarks or trademarks of Ampere Computing.

# Table of contents

Component identification.....	10
Front panel components.....	10
Front panel LEDs and buttons.....	13
UID button functionality.....	16
Front panel LED power fault codes.....	16
Systems Insight Display LEDs.....	16
Systems Insight Display combined LED descriptions.....	18
Rear panel components.....	20
Rear panel LEDs.....	21
System board components.....	23
System maintenance switch descriptions.....	24
NMI functionality.....	25
DIMM slot locations.....	25
DIMM label identification.....	26
NVDIMM identification.....	28
NVDIMM 2D Data Matrix barcode.....	29
NVDIMM LED identification.....	30
NVDIMM-N LED combinations.....	30
NVDIMM Function LED patterns.....	31
Intel Optane persistent memory 100 series for HPE label identification.....	32
Processor, heatsink, and socket components.....	33
Device numbers.....	34
Hot-plug drive LED definitions.....	36
Smart Carrier NVMe (SCN) drive LED definitions.....	37
HPE Basic Drive LED definitions.....	38
uFF drive components and LEDs.....	40
Hot-plug fans.....	42
HPE Smart Array P824i-p MR Gen10 Controller.....	44
HPE NS204i-p NVMe OS Boot Device components.....	45
HPE NS204i-p NVMe OS Boot Device LED definitions.....	46
HPE InfiniBand HDR/Ethernet 940QSFP 56x16 adapter LEDs.....	46
DSC-25 2-port SFP28 card ports and LEDs.....	48
Operations.....	49
Power up the server.....	50

Power down the server.....	50
Extend the server from the rack.....	51
Remove the server from the rack.....	52
Remove the access panel.....	52
Install the access panel.....	53
Remove the hot-plug fan.....	53
Remove the primary PCI riser cage.....	55
Install the primary PCI riser cage.....	56
Remove the secondary PCI riser cage.....	57
Install the secondary PCI riser cage.....	59
Remove the 8 SFF drive backplane.....	60
Release the cable management arm .....	62
Setup.....	62
Optimum environment.....	63
Space and airflow requirements.....	63
Temperature requirements.....	64
Power requirements.....	65
Electrical grounding requirements.....	65
Connecting a DC power cable to a DC power source.....	66
Server warnings and cautions.....	68
Rack warnings.....	69
Identifying the contents of the server shipping carton.....	70
Installing hardware options .....	70
Installing the server in a rack.....	70
Installing the server with the easy install rail kit.....	71
Installing the server in a rack with the ball-bearing rail kit.....	78
Operating system.....	85
Installing the operating system with Intelligent Provisioning.....	86
Selecting boot options in UEFI Boot Mode.....	86
Selecting boot options.....	87
Hardware options installation.....	87
Hewlett Packard Enterprise product QuickSpecs.....	88
Introduction.....	89
Installing the cable management arm.....	89
Installing a redundant hot-plug power supply.....	92
Memory options.....	94
DIMM and NVDIMM population information.....	95
DIMM-processor compatibility.....	95

HPE SmartMemory speed information.....	95
Installing a DIMM.....	95
HPE 16GB NVDIMM option.....	97
NVDIMM-processor compatibility.....	97
Server requirements for NVDIMM support.....	98
Installing an NVDIMM.....	98
Configuring the server for NVDIMMs .....	101
NVDIMM sanitization.....	101
NVDIMM relocation guidelines.....	102
Intel Optane persistent memory 100 series for HPE.....	103
Persistent memory module-processor compatibility.....	103
Persistent memory module population information.....	104
System requirements for persistent memory module support.....	104
Installing persistent memory modules.....	105
Configuring the server for Intel Optane persistent memory 100 series for HPE.....	107
Installing a high-performance fan.....	108
Drive options.....	111
Hot-plug drive guidelines.....	112
Removing the hard drive blank.....	112
Installing a hot-plug SAS or SATA drive.....	113
Removing a hot-plug SAS or SATA hard drive.....	114
Installing the NVMe drives.....	115
Removing and replacing an NVMe drive.....	117
Installing a uFF drive and SCM drive carrier.....	118
Removing and replacing a uFF drive.....	119
Installing a hot-plug SAS/SATA basic drive.....	121
Removing a hot-plug SAS/SATA basic drive.....	123
Installing an 8 SFF optical drive.....	124
Universal media bay options.....	127
Installing a 2 SFF SAS/SATA drive cage.....	127
Installing a 2 SFF NVMe drive cage option.....	131
Installing a 2 SFF HPE Smart Carrier M.2 (SCM) drive cage.....	135
Installing an 8 SFF display port/USB/optical blank option.....	139
Installing the 4 LFF optical drive option.....	142
Installing the rear drive riser cage option.....	145
Primary PCI riser cage options.....	150
Installing an optional primary PCI riser board .....	151
Installing the SATA M.2 2280 riser option.....	153

Installing an expansion board in the primary riser cage.....	156
Installing an accelerator or GPU in the primary riser cage.....	158
Secondary PCI riser options.....	161
Installing a secondary full-height PCI riser cage option.....	161
Installing a secondary low-profile PCIe slot riser cage option.....	167
Installing an expansion board in the secondary riser cage.....	168
Installing an accelerator or GPU in the secondary riser cage.....	172
Controller options.....	175
Installing an HPE Smart Array P408i-a SR Gen10 Controller option.....	176
Installing an HPE Smart Array P408i-p SR Gen10 Controller option.....	180
Installing an HPE Smart Array P816i-a SR Gen10 Controller option.....	186
Installing an HPE Smart Array P824i-p MR Gen10 controller in a configured server.....	189
Installing the operating system with the HPE Smart Array MR Gen10 P824i-p controller driver.....	192
Processor and heatsink options.....	193
Installing a processor heatsink assembly.....	193
Installing a high performance heatsink.....	196
Installing the Systems Insight Display power module.....	201
Installing the 4 LFF display port/USB module.....	207
Installing the serial cable option.....	210
Installing the Chassis Intrusion Detection switch option.....	212
Installing the FlexibleLOM option.....	215
Installing the Pensando DSP DSC-25 2p SFP28 card with the iLO Sideband ALOM Module.....	217
Installing the HPE NS204i-p Gen10 Plus Boot Device option.....	224
Energy pack options.....	227
HPE Smart Storage Battery.....	227
HPE Smart Storage Hybrid Capacitor.....	228
Minimum firmware versions.....	228
Energy pack option configurations.....	229
Installing an energy pack in the 10 SFF SAS/SATA/NVMe Combo backplane configuration.....	229
Installing an energy pack in 8 SFF and 4 LFF configurations .....	234
HPE Trusted Platform Module 2.0 Gen10 option.....	236
Overview.....	237
HPE Trusted Platform Module 2.0 Guidelines.....	237
Installing and enabling the HPE TPM 2.0 Gen10 option.....	238
Installing the Trusted Platform Module board.....	238
Preparing the server for installation.....	239

Installing the TPM board and cover.....	240
Preparing the server for operation.....	242
Enabling the Trusted Platform Module.....	243
Enabling the Trusted Platform Module as TPM 2.0.....	243
Enabling the Trusted Platform Module as TPM 1.2.....	244
Retaining the BitLocker recovery key/password.....	245
Cabling.....	245
Cabling overview .....	245
SFF cables.....	246
SFF configuration cable routing.....	247
SFF backplane to P824i-p controller.....	247
8 SFF backplane to a P408i-a/P816i-a controller.....	250
2 SFF backplane to P816i-a controller.....	252
10 SFF NVMe backplane to NVMe riser.....	252
2 SFF NVMe backplane to primary riser.....	254
1 SFF rear backplane to system board SATA.....	255
10 SFF backplane to P408i-a controller.....	255
Additional SFF cabling.....	256
LFF cables.....	257
LFF configuration cable routing.....	257
4 LFF backplane to P408i-a controller.....	258
Additional LFF cabling.....	258
Software and configuration utilities.....	258
Server mode.....	259
HPE iLO 5.....	260
iLO Federation.....	260
iLO RESTful API.....	261
RESTful Interface Tool.....	261
DescriptioniLO Amplifier Pack.....	261
Integrated Management Log.....	262
Intelligent Provisioning.....	262
Intelligent Provisioning operation.....	263
Management security.....	264
Scripting Toolkit for Windows and Linux.....	265
UEFI System Utilities.....	265
Selecting the boot mode .....	266
Secure Boot.....	267
Launching the Embedded UEFI Shell .....	268

HPE Smart Storage Administrator.....	268
HPE MR Storage Administrator.....	269
HPE InfoSight for servers .....	270
StorCLI.....	270
USB support.....	271
External USB functionality.....	271
Redundant ROM support.....	271
Safety and security benefits.....	271
Keeping the system current.....	272
Updating firmware or system ROM.....	272
Service Pack for ProLiant.....	273
Introduction to Smart Update Manager.....	273
Integrated Smart Update Tools.....	274
Updating firmware from the System Utilities .....	274
Updating the firmware from the UEFI Embedded Shell .....	275
Online Flash components.....	276
Drivers.....	276
Software and firmware.....	276
Operating system version support.....	277
HPE Pointnext Portfolio.....	277
Proactive notifications.....	278
Troubleshooting.....	278
Troubleshooting resources.....	278
Removing and replacing the system battery.....	279
Specifications.....	280
Environmental specifications.....	281
Server specifications.....	281
Power supply specifications.....	282
HPE 500 W Flex Slot Platinum Hot-plug Low Halogen Power Supply.....	283
HPE 800 W Flex Slot Platinum Hot-plug Low Halogen Power Supply.....	284
HPE 800 W Flex Slot Titanium Hot-plug Low Halogen Power Supply.....	285
HPE 800 W Flex Slot Universal Hot-plug Low Halogen Power Supply.....	285
HPE 800 W Flex Slot -48 VDC Hot-plug Low Halogen Power Supply.....	286
HPE 1600 W Flex Slot Platinum Hot-plug Low Halogen Power Supply.....	289
Hot-plug power supply calculations.....	289
Websites.....	290
Support and other resources.....	290
Accessing Hewlett Packard Enterprise Support.....	290

Accessing updates.....	291
Remote support.....	292
Warranty information.....	292
Regulatory information.....	293
Documentation feedback.....	293

# Component identification

## Subtopics

[Front panel components](#)

[Front panel LEDs and buttons](#)

[Systems Insight Display LEDs](#)

[Systems Insight Display combined LED descriptions](#)

[Rear panel components](#)

[Rear panel LEDs](#)

[System board components](#)

[Processor, heatsink, and socket components](#)

[Device numbers](#)

[Hot-plug drive LED definitions](#)

[Smart Carrier NVMe \(SCN\) drive LED definitions](#)

[HPE Basic Drive LED definitions](#)

[uFF drive components and LEDs](#)

[Hot-plug fans](#)

[HPE Smart Array P824i-p MR Gen10 Controller](#)

[HPE NS204i-p NVMe OS Boot Device components](#)

[HPE NS204i-p NVMe OS Boot Device LED definitions](#)

[HPE InfiniBand HDR/Ethernet 940QSFP 56x16 adapter LEDs](#)

[DSC-25 2-port SFP28 card ports and LEDs](#)

## Front panel components

8 SFF

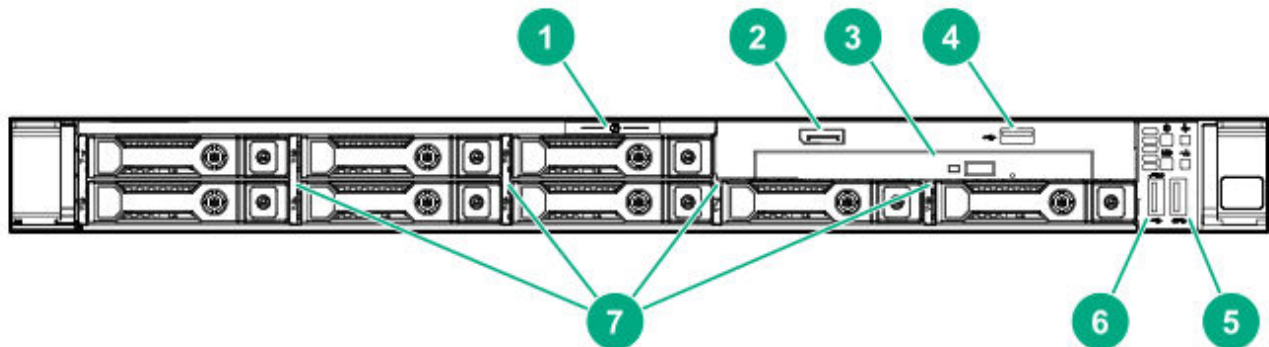

Item	Description
1	Serial label pull tab
2	Display port (optional)
3	Optical drive (optional)
4	USB 2.0 port (optional)
5	USB 3.0 port
6	iLO Service Port The operating system does not recognize this port as a USB port.
7	SAS/SATA drive bays

#### 4 LFF

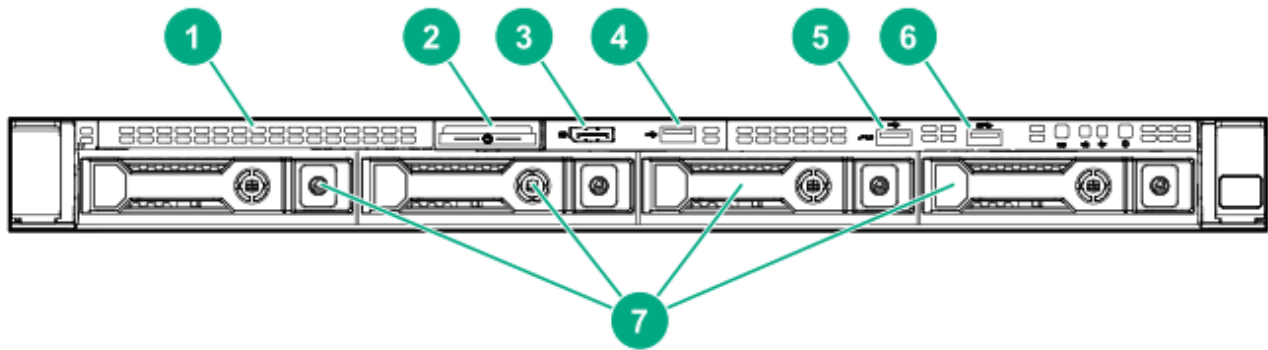

Item	Description
1	Optical drive blank (optional)
2	Serial label pull tab
3	Display port (optional)
4	USB 2.0 port (optional)
5	iLO Service Port The operating system does not recognize this port as a USB port.
6	USB 3.0 port
7	SAS/SATA drive bays

## 10 SFF NVMe/SAS Combo

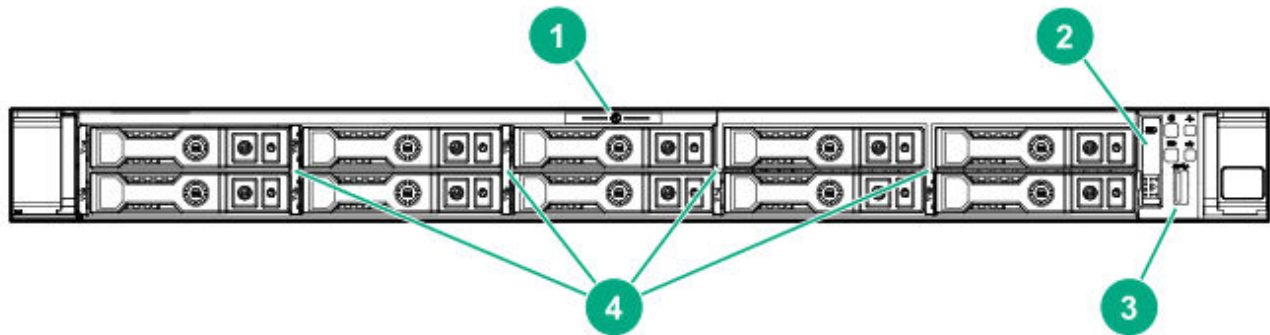

Item	Description
1	Serial label pull tab
2	Systems Insight Display (optional)
3	USB 3.0 port
4	SAS/SATA/NVMe drive bays When the 10 SFF NVMe/SAS backplane option is installed, NVMe drives must be installed in bays 9 and 10. The other bays support a mix of NVMe and SAS drives.

# Front panel LEDs and buttons

8 SFF/10 SFF

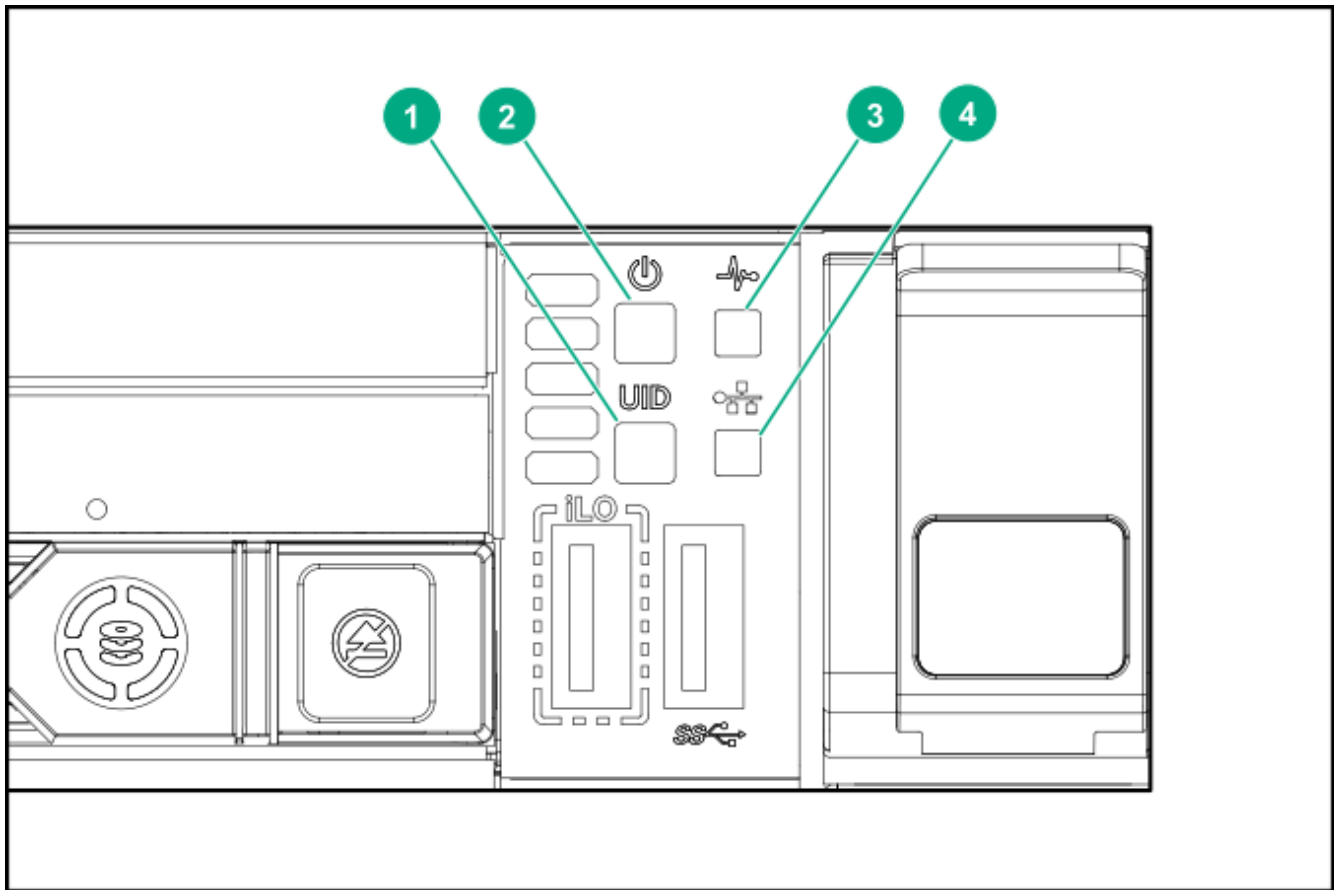

Item	Description	Status
1	UID button/LED <sup>1</sup>	Solid blue = Activated Flashing blue: <ul style="list-style-type: none"><li>• 1 Hz = Remote management or firmware upgrade in progress</li><li>• 4 Hz = iLO manual reboot sequence initiated</li><li>• 8 Hz = iLO manual reboot sequence in progress</li></ul> Off = Deactivated
2	Power On/Standby button and system power LED <sup>1</sup>	Solid green = System on Flashing green = Performing power on sequence Solid amber = System in standby Off = No power present <sup>2</sup>

Item	Description	Status
3	Health LED <sup>1</sup>	Solid green = Normal Flashing green = iLO is rebooting. Flashing amber = System degraded Flashing red = System critical <sup>3</sup>
4	NIC status LED <sup>1</sup>	Solid green = Link to network Flashing green = Network active Off = No network activity

<sup>1</sup> When all four LEDs described in this table flash simultaneously, a power fault has occurred.  
<sup>2</sup> Facility power is not present, power cord is not attached, no power supplies are installed, power supply failure has occurred, or the power button cable is disconnected.  
<sup>3</sup> If the health LED indicates a degraded or critical state, review the system IML or use iLO to review the system health status.

**4 LFF**

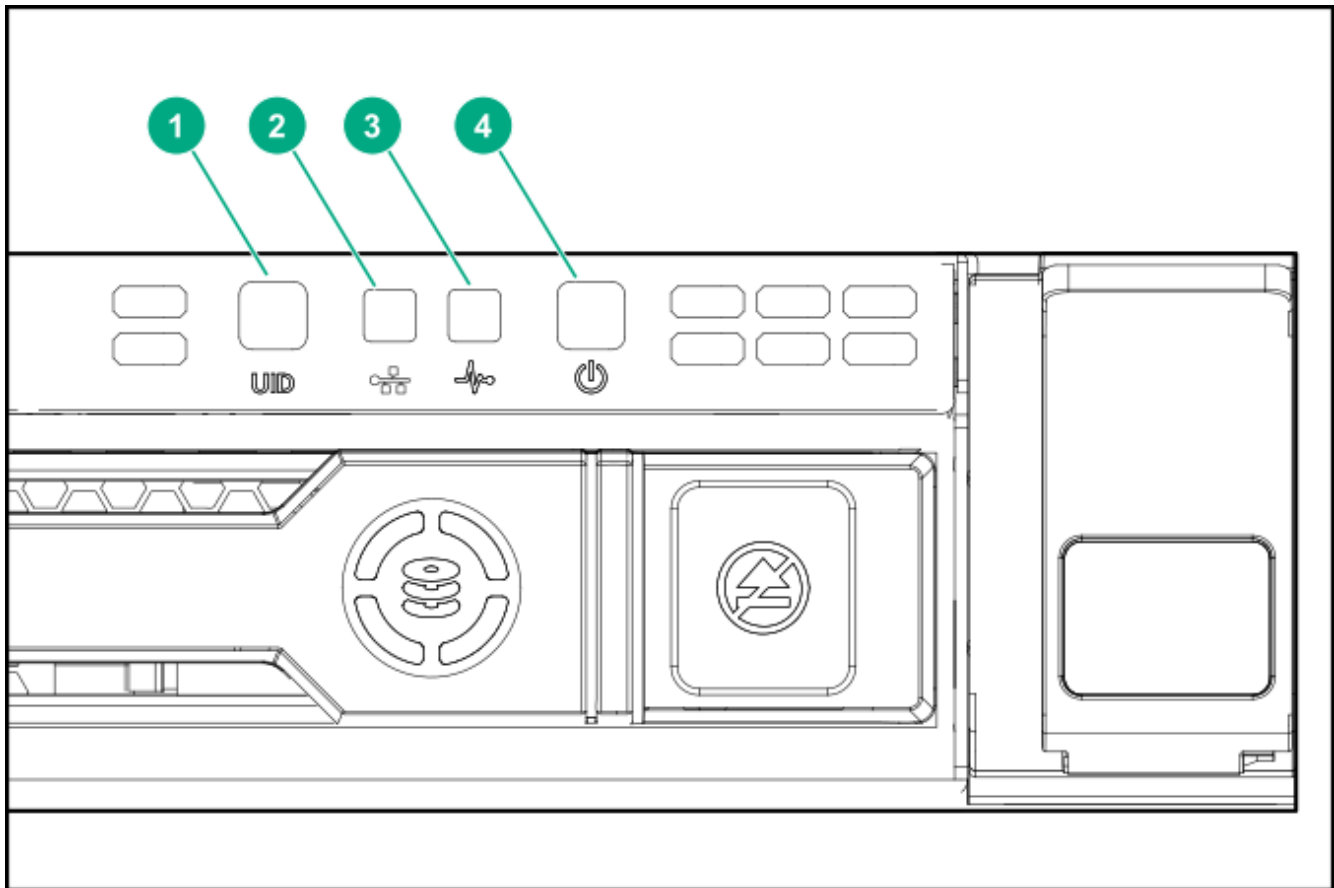

Item	Description	Status
1	UID button/LED <sup>1</sup> <sub>–</sub>	<p>Solid blue = Activated.</p> <p>Flashing blue:</p> <ul style="list-style-type: none"> <li>• 1 Hz = Remote management or firmware upgrade in progress.</li> <li>• 4 Hz = iLO manual reboot sequence initiated.</li> <li>• 8 Hz = iLO manual reboot sequence in progress.</li> </ul> <p>Off = Deactivated.</p>
2	NIC status LED <sup>1</sup>	<p>Solid green = Link to network.</p> <p>Flashing green = Network active.</p> <p>Off = No network activity.</p>
3	Health LED <sup>1</sup>	<p>Solid green = Normal.</p> <p>Flashing green = iLO is rebooting.</p> <p>Flashing amber = System degraded.</p> <p>Flashing red = System critical. <sup>2</sup><sub>–</sub></p>
4	Power On/Standby button and system power LED <sup>1</sup>	<p>Solid green = System on.</p> <p>Flashing green = Performing power on sequence.</p> <p>Solid amber = System in standby.</p> <p>Off = No power present. <sup>3</sup><sub>–</sub></p>

<sup>1</sup> When all four LEDs described in this table flash simultaneously, a power fault has occurred.

<sup>2</sup> To identify components in a degraded or critical state, see the Systems Insight Display LEDs, check iLO/BIOS logs, and reference the server troubleshooting guide.

<sup>3</sup> Facility power is not present, power cord is not attached, no power supplies are installed, power supply failure has occurred, or the power button cable is disconnected.

## Subtopics

### UID button functionality

### Front panel LED power fault codes

## UID button functionality

The UID button can be used to identify a specific server in a rack or display the Server Health Summary when the server will not power on. For more information, see the latest HPE iLO User Guide on the [Hewlett Packard Enterprise website](#).

## Front panel LED power fault codes

The following table provides a list of power fault codes, and the subsystems that are affected. Not all power faults are used by all servers.

<b>Subsystem</b>	<b>LED behavior</b>
System board	1 flash
Processor	2 flashes
Memory	3 flashes
Riser board PCIe slots	4 flashes
FlexibleLOM	5 flashes
Storage controllers	6 flashes
System board PCIe slots	7 flashes
Power backplane or storage backplane	8 flashes
Power supply	9 flashes

## Systems Insight Display LEDs

The Systems Insight Display LEDs represent the system board layout. The display enables diagnosis with the access panel installed.

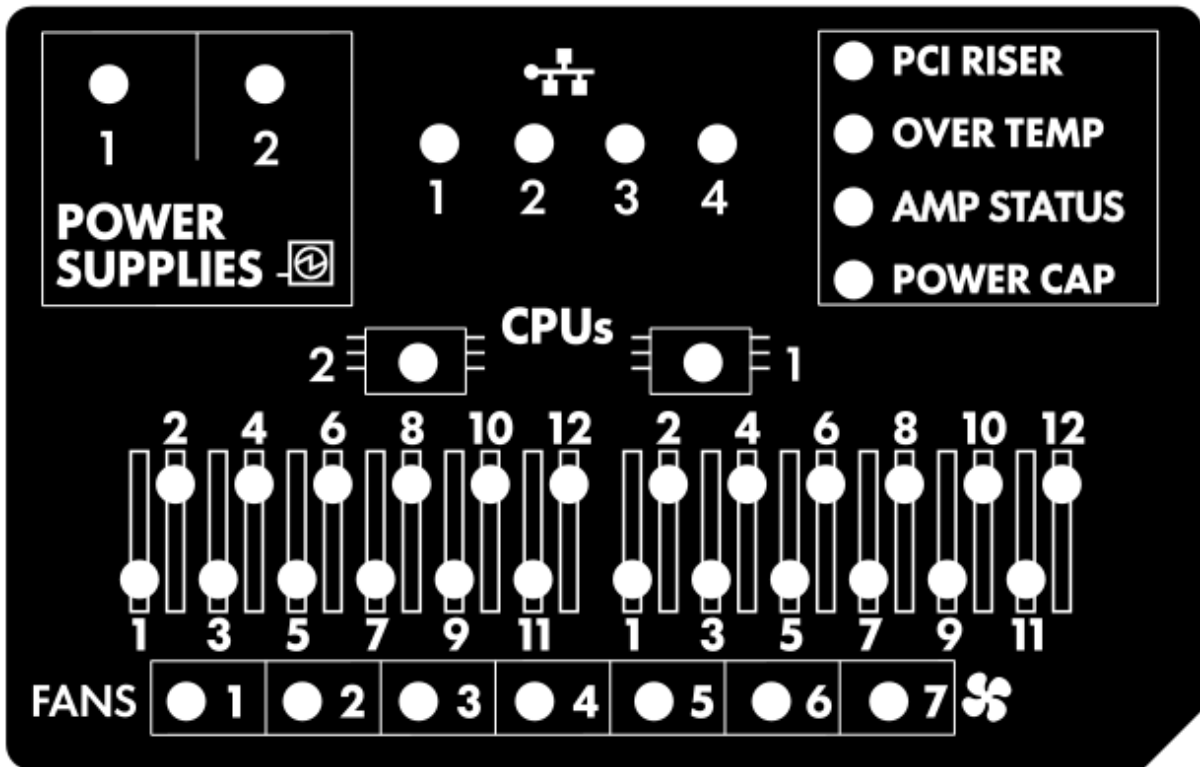

Description	Status
Processor LEDs	Off = Normal Amber = Failed processor
DIMM LEDs	Off = Normal Amber = Failed DIMM or configuration issue
Fan LEDs	Off = Normal Amber = Failed fan or missing fan
NIC LEDs <u>1</u>	Off = No link to network Solid green = Network link Flashing green = Network link with activity If power is off, the front panel LED is not active. For status, see <a href="#">Rear panel LEDs</a> .
Power supply LEDs	Off = Normal

Description	Status
PCI riser LED	Solid amber = Power subsystem degraded, power supply failure, or input power lost.
Over temp LED	Off = Normal Amber = Incorrectly installed PCI riser cage
Amp Status LED	Off = AMP modes disabled Solid green = AMP mode enabled Solid amber = Failover Flashing amber = Invalid configuration
Power cap LED	Off = System is in standby, or no cap is set. Solid green = Power cap applied

<sup>1</sup> For Networking Choice (NC) server models, the embedded NIC ports are not equipped on the server. Therefore, the NIC LEDs on the Systems Insight Display will flash based on the FlexibleLOM network port activity. In the case of a dual-port FlexibleLOM, only NIC LED 1 and 2 will illuminate to correspond with the activity of the respective network ports.

When the health LED on the front panel illuminates either amber or red, the server is experiencing a health event. For more information on the combination of these LEDs, see [Systems Insight Display combined LED descriptions](#).

## Systems Insight Display combined LED descriptions

The combined illumination of the following LEDs indicates a system condition:

- Systems Insight Display LEDs
- System power LED
- Health LED

**Systems Insight Display LED and Health LED System power LED Status**

Systems Insight Display LED and Health LED	System power LED	Status
Processor (amber)	Red	Amber
Processor (amber)	Amber	Green
DIMM (amber)	Red	Green
DIMM (amber)	Amber	Green
Over temp (amber)	Amber	Green
Over temp (amber)	Red	Amber
PCI riser (amber)	Red	Green
Fan (amber)	Amber	Green
Fan (amber)	Red	Green
Power supply (amber)	Red	Amber
Power supply (amber)	Amber	Green

One or more of the following conditions might exist:

- Processor in socket X has failed.
- Processor X is not installed in the socket.
- Processor X is unsupported.
- ROM detects a failed processor during POST.

Processor in socket X is in a pre-failure condition.

One or more DIMMs have failed.

DIMM in slot X is in a pre-failure condition.

The Health Driver has detected a cautionary temperature level.

The server has detected a hardware critical temperature level.

The PCI riser cage is not seated properly.

One fan has failed or has been removed.

Two or more fans have failed or been removed.

One or more of the following conditions might exist:

- Only one power supply is installed and that power supply is in standby.
- Power supply fault.
- System board fault.

One or more of the following conditions might exist:

- Redundant power supply is installed and only one power supply is functional.
- AC power cord is not plugged into redundant power supply.
- Redundant power supply fault.

**Systems Insight Display LED and Health LED System power Status  
d color LED**

Systems Insight Display LED color	Health LED	System power LED	Status
			<ul style="list-style-type: none"> <li>Power supply mismatch at POST or power supply mismatch through hot-plug addition.</li> </ul>
Power cap (off)	—	Amber	Standby.
Power cap (green)	—	Flashing green	Waiting for power.
Power cap (green)	—	Green	Power is available.
Power cap (flashing amber)	—	Amber	Power is not available.

**!** **IMPORTANT:** If more than one DIMM slot LED is illuminated, further troubleshooting is required. Test each bank of DIMMs by removing all other DIMMs. Isolate the failed DIMM by replacing each DIMM in a bank with a known working DIMM.

**Rear panel components**

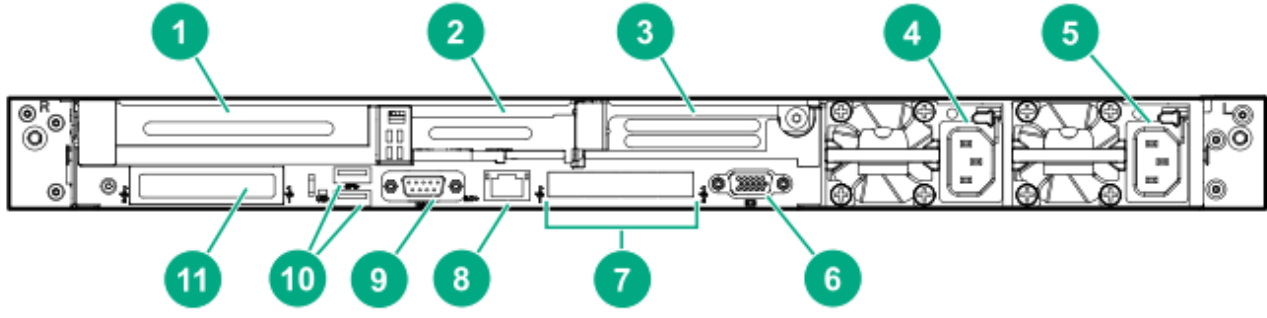

Item	Description
1	Slot 1 PCIe3
2	Slot 2 PCIe3
3	Slot 3 PCIe3 (optional - requires second processor)
4	Power supply 2 (PS2)
5	Power supply 1 (PS1)

Item	Description
6	Video port
7	NIC ports (if equipped)
8	iLO Management Port
9	Serial port (optional)
10	USB 3.0 ports
11	FlexibleLOM (optional)

## Rear panel LEDs

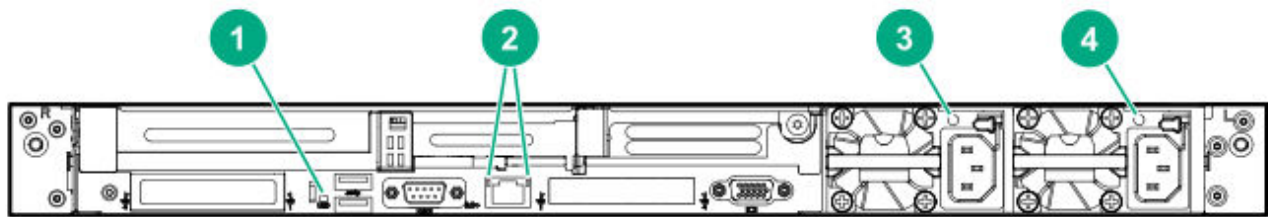

Item	Description	Status
1	UID LED	<p>Solid blue = Identification is activated.</p> <p>Flashing blue = System is being managed remotely.</p> <p>Off = Identification is deactivated.</p>
2R	iLO 5/standard NIC activity LED	<p>Solid green = Activity exists.</p> <p>Flashing green = Activity exists.</p> <p>Off = No activity exists.</p>
2L	iLO 5/standard NIC link LED	<p>Solid green = Link exists.</p> <p>Off = No link exists.</p>
3	Power supply 2 LED	<p>Solid green = Normal</p> <p>Off = One or more of the following conditions exists:</p>

Item	Description	Status
4	Power supply 1 LED	<ul style="list-style-type: none"> <li>• AC power unavailable</li> <li>• Power supply failed</li> <li>• Power supply in standby mode</li> <li>• Power supply exceeded current limit.</li> </ul> <hr/> <p>Solid green = Normal</p> <p>Off = One or more of the following conditions exists:</p> <ul style="list-style-type: none"> <li>• AC power unavailable</li> <li>• Power supply failed</li> <li>• Power supply in standby mode</li> <li>• Power supply exceeded current limit.</li> </ul>

## System board components

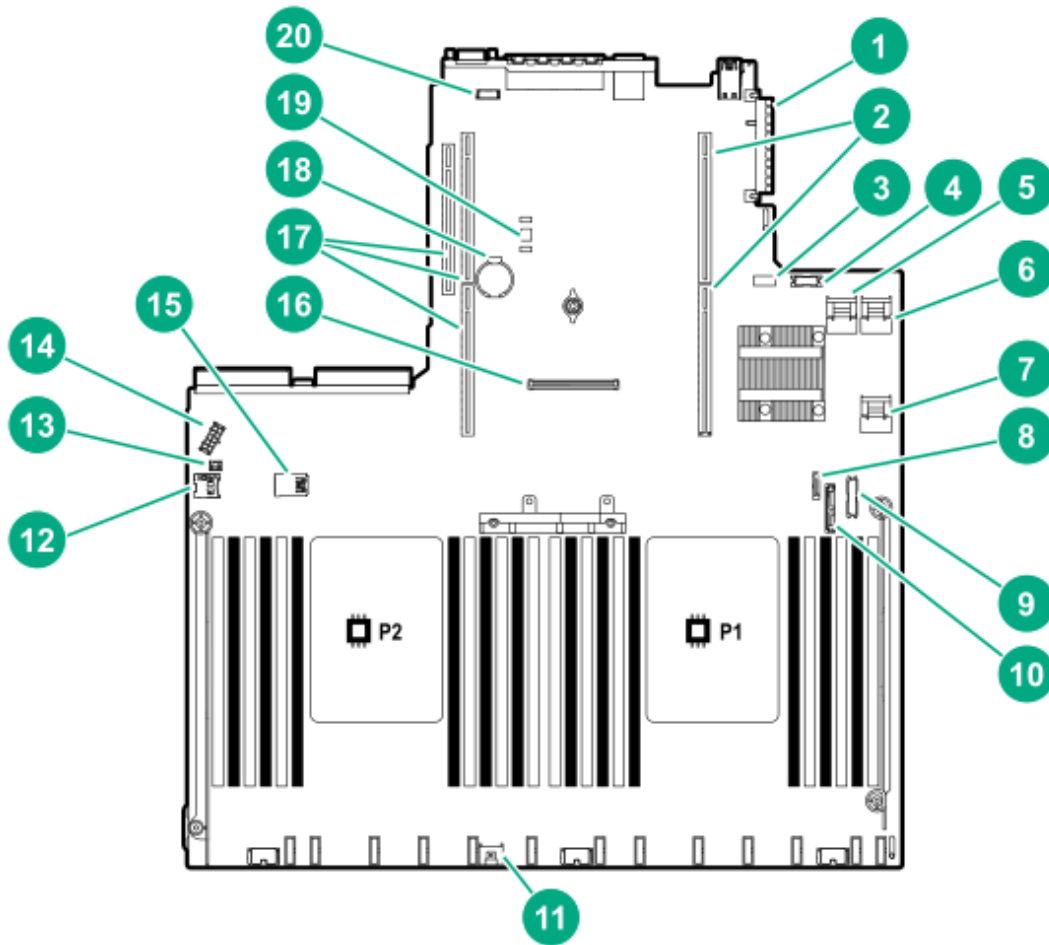

Item	Description
1	FlexibleLOM connector
2	Primary (processor 1) PCIe riser connector
3	System maintenance switch
4	Front display port/USB 2.0 connector
5	x4 SATA port 1
6	x4 SATA port 2
7	x2 SATA port 3
8	x1 SATA port 4
9	Front power/USB 3.0 connector
10	Optical/SATA port 5
11	Energy pack connector

Item	Description
12	microSD card slot
13	Chassis Intrusion Detection connector
14	Drive backplane power connector
15	Dual internal USB 3.0 connector
16	Type-a SmartArray connector
17	Secondary (processor 2) PCIe riser connector
18	System battery
19	TPM connector (optional)
20	Serial port connector (optional)

## Subtopics

### System maintenance switch descriptions

#### NMI functionality

#### DIMM slot locations

#### DIMM label identification

#### NVDIMM identification

#### NVDIMM LED identification

#### Intel Optane persistent memory 100 series for HPE label identification

## System maintenance switch descriptions

Position	Default	Function
S1 $\frac{1}{-}$	Off	<ul style="list-style-type: none"> <li>Off— iLO security is enabled.</li> <li>On— iLO security is disabled.</li> </ul>
S2	Off	Reserved
S3	Off	Reserved
S4	Off	Reserved
S5 $\frac{1}{-}$	Off	<ul style="list-style-type: none"> <li>Off—Power-on password is enabled.</li> <li>On—Power-on password is disabled.</li> </ul>

Position	Default	Function
S6 <sup>1</sup> , <sup>2</sup> , <sup>3</sup>	Off	<ul style="list-style-type: none"> <li>Off—No function</li> <li>On—Restore default manufacturing settings</li> </ul>
S7	Off	Reserved
S8	Off	Reserved
S9	Off	Reserved
S10	Off	Reserved
S11	Off	Reserved
S12	Off	Reserved

<sup>1</sup> To access the redundant ROM, set S1, S5, and S6 to On.

<sup>2</sup> When the system maintenance switch position 6 is set to the On position, the system is prepared to restore all configuration settings to their manufacturing defaults.

<sup>3</sup> When the system maintenance switch position 6 is set to the On position and Secure Boot is enabled, some configurations cannot be restored. For more information, see [Configuring the server](#).

## NMI functionality

An NMI crash dump enables administrators to create crash dump files when a system is hung and not responding to traditional debugging methods.

An analysis of the crash dump log is an essential part of diagnosing reliability problems, such as hanging operating systems, device drivers, and applications. Many crashes freeze a system, and the only available action for administrators is to cycle the system power. Resetting the system erases any information that could support problem analysis, but the NMI feature preserves that information by performing a memory dump before a hard reset.

To force the OS to initiate the NMI handler and generate a crash dump log, the administrator can use the iLO Generate NMI feature.

## DIMM slot locations

DIMM slots are numbered sequentially (1 through 12) for each processor.

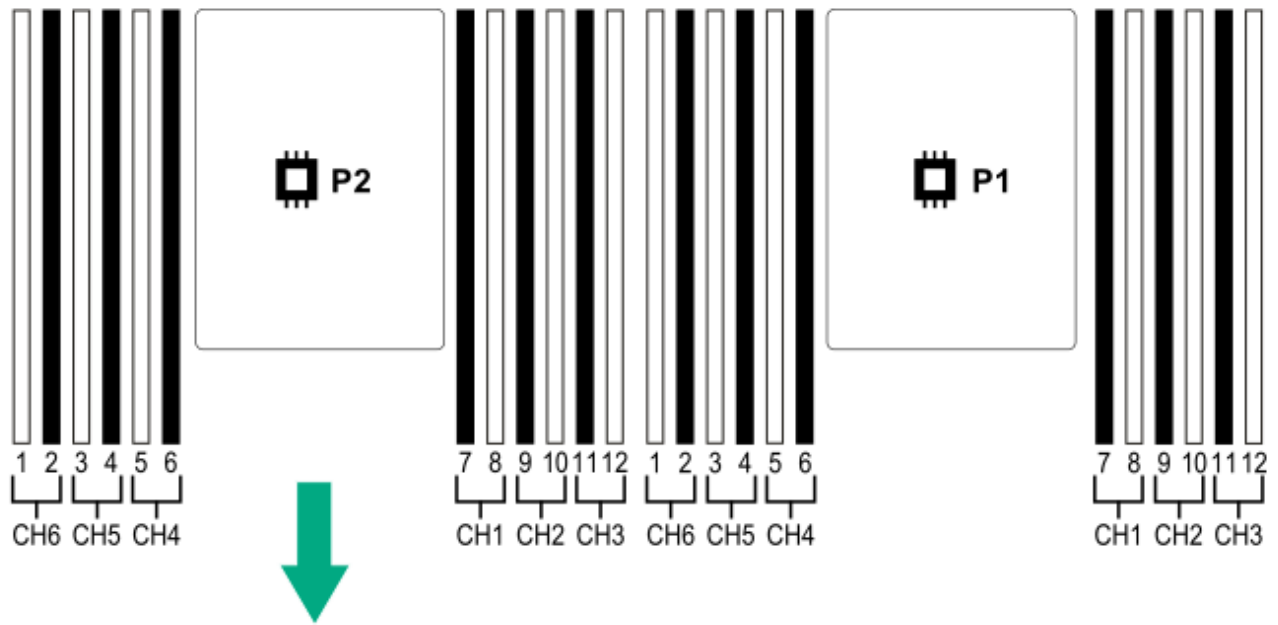

## DIMM label identification

To determine DIMM characteristics, see the label attached to the DIMM. The information in this section helps you to use the label to locate specific information about the DIMM.

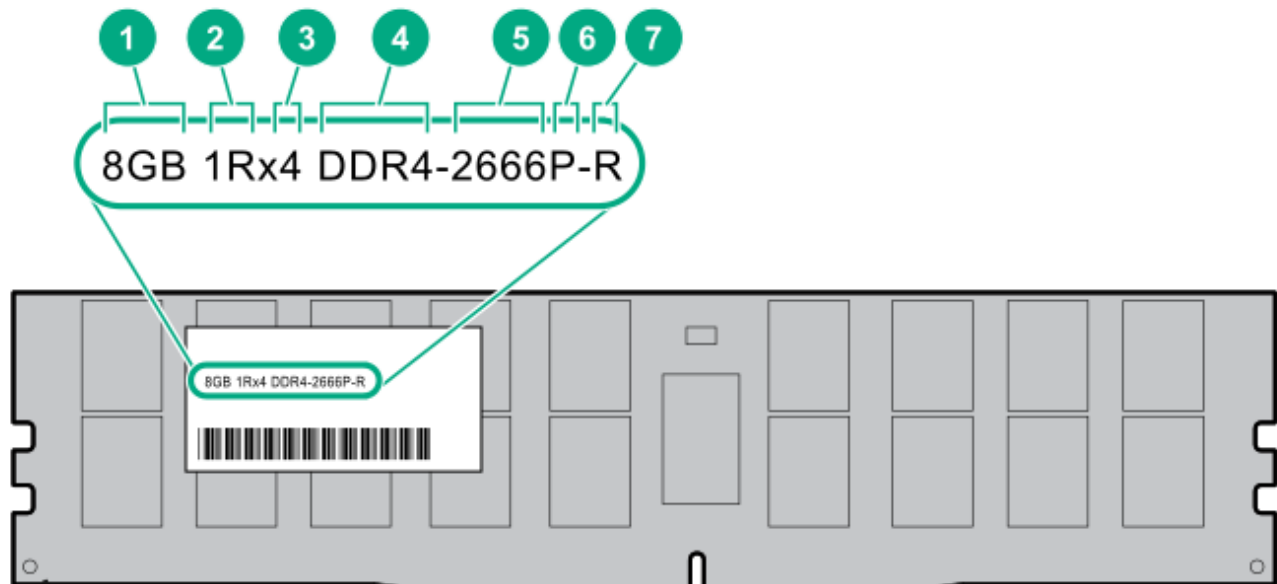

Item	Description	Example
1	Capacity	8 GB 16 GB 32 GB 64 GB 128 GB
2	Rank	1R = Single rank 2R = Dual rank 4R = Quad rank 8R = Octal rank
3	Data width on DRAM	x4 = 4-bit x8 = 8-bit x16 = 16-bit
4	Memory generation	PC4 = DDR4
5	Maximum memory speed	2133 MT/s 2400 MT/s 2666 MT/s 2933 MT/s
6	CAS latency	P = CAS 15-15-15 T = CAS 17-17-17 U = CAS 20-18-18 V = CAS 19-19-19 (for RDIMM, LRDIMM) V = CAS 22-19-19 (for 3DS TSV LRDIMM) Y = CAS 21-21-21 (for RDIMM, LRDIMM) Y = CAS 24-21-21 (for 3DS TSV LRDIMM)
7	DIMM type	R = RDIMM (registered) L = LRDIMM (load reduced) E = Unbuffered ECC (UDIMM)

For more information about product features, specifications, options, configurations, and compatibility, see the HPE DDR4 SmartMemory QuickSpecs on the Hewlett Packard Enterprise website (<https://www.hpe.com/support/DDR4SmartMemoryQS>).

## NVDIMM identification

NVDIMMs are supported only when first-generation Intel Xeon Scalable processors are installed on the server.

NVDIMM boards are blue instead of green. This change to the color makes it easier to distinguish NVDIMMs from DIMMs.

To determine NVDIMM characteristics, see the full product description as shown in the following example:

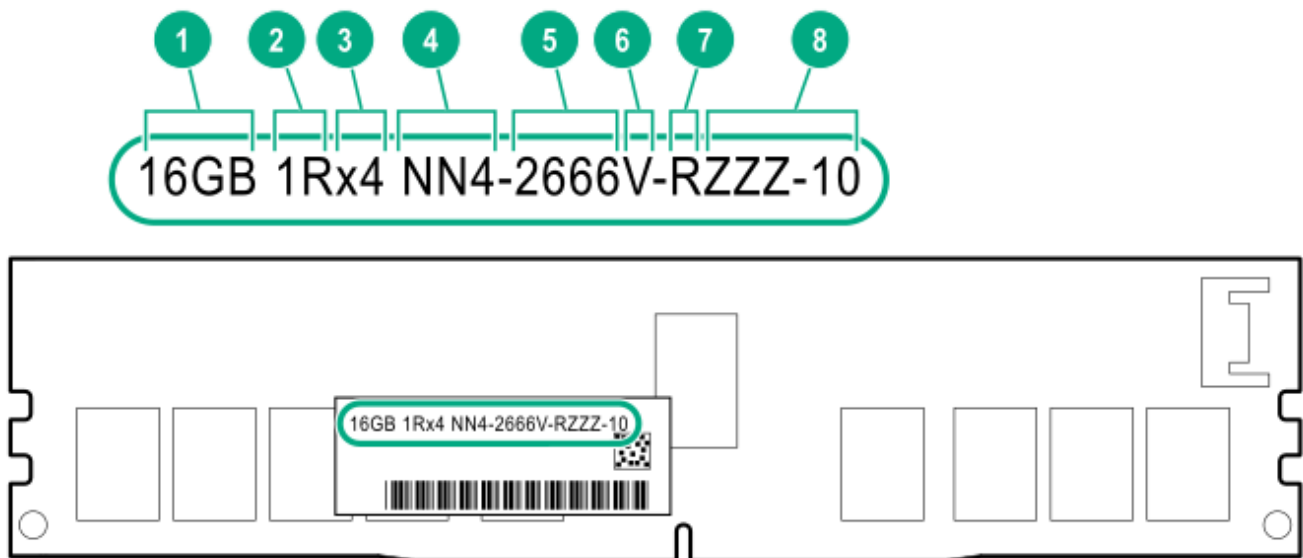

Item	Description	Definition
1	Capacity	16 GiB
2	Rank	1R (Single rank)
3	Data width per DRAM chip	x4 (4 bit)
4	Memory type	NN4=DDR4 NVDIMM-N
5	Maximum memory speed	2667 MT/s
6	Speed grade	V (latency 19-19-19)
7	DIMM type	RDIMM (registered)
8	Other	—

For more information about NVDIMMs, see the product QuickSpecs on the Hewlett Packard Enterprise website (<https://www.hpe.com/info/qs>).

## Subtopics

### NVDIMM 2D Data Matrix barcode

## NVDIMM 2D Data Matrix barcode

The 2D Data Matrix barcode is on the right side of the NVDIMM label and can be scanned by a cell phone or other device.

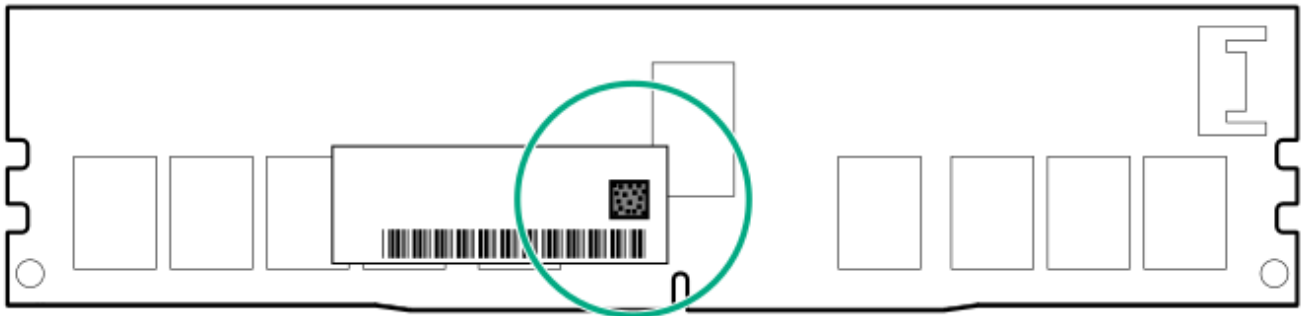

When scanned, the following information from the label can be copied to your cell phone or device:

- (P) is the module part number.
- (L) is the technical details shown on the label.
- (S) is the module serial number.

Example: (P)HMN82GR7AFR4N-VK (L)16GB 1Rx4 NN4-2666V-RZZZ-10(S)80AD-01-1742-11AED5C2

## NVDIMM LED identification

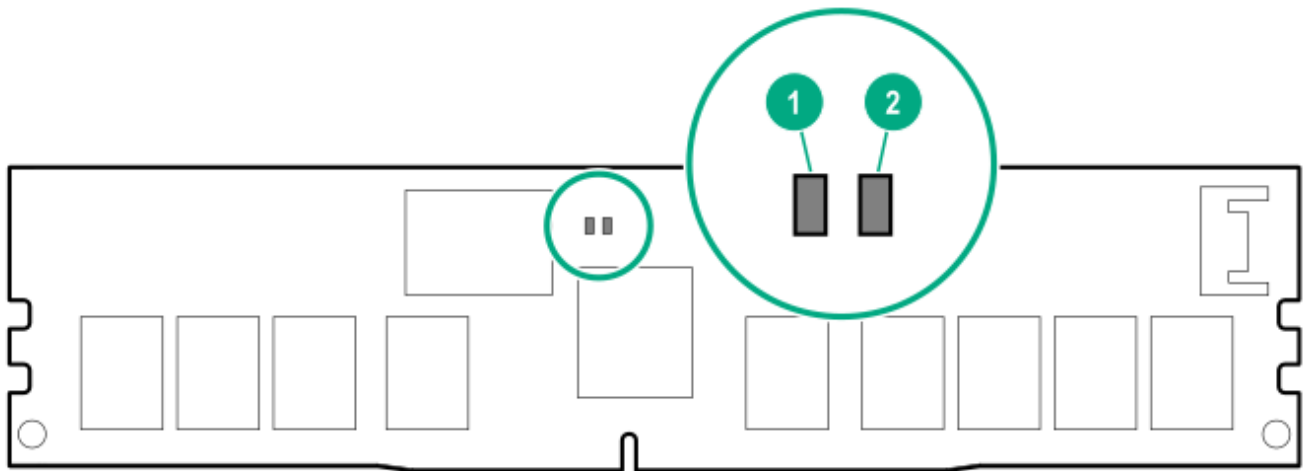

Item	LED description	LED color
1	Power LED	Green
2	Function LED	Blue

### Subtopics

- [NVDIMM-N LED combinations](#)
- [NVDIMM Function LED patterns](#)

## NVDIMM-N LED combinations

State	Definition	NVDIMM-N Power LED (green)	NVDIMM-N Function LED (blue)
0	AC power is on (12V rail) but the NVM controller is not working or not ready.	On	Off
1	AC power is on (12V rail) and the NVM controller is ready.	On	On
2	AC power is off or the battery is off (12V rail off).	Off	Off

State	Definition	NVDIMM-N Power LED (green)	NVDIMM-N Function LED (blue)
3	AC power is on (12V rail) or the battery is on (12V rail) and the NVDIMM-N is active (backup and restore).	On	Flashing

## NVDIMM Function LED patterns

For the purpose of this table, the NVDIMM-N LED operates as follows:

- Solid indicates that the LED remains in the on state.
- Flashing indicates that the LED is on for 2 seconds and off for 1 second.
- Fast-flashing indicates that the LED is on for 300 ms and off for 300 ms.

State	Definition	NVDIMM-N Function LED
0	The restore operation is in progress.	Flashing
1	The restore operation is successful.	Solid or On
2	Erase is in progress.	Flashing
3	The erase operation is successful.	Solid or On
4	The NVDIMM-N is armed, and the NVDIMM-N is in normal operation.	Solid or On
5	The save operation is in progress.	Flashing
6	The NVDIMM-N finished saving and battery is still turned on (12 V still powered).	Solid or On
7	The NVDIMM-N has an internal error or a firmware update is in progress. For more information about an NVDIMM-N internal error, see the IML.	Fast-flashing

# Intel Optane persistent memory 100 series for HPE label identification



Item	Description	Example
1	Unique ID number	8089-A2-1802-1234567
2	Model number	NMA1XBD512G2S
3	Capacity	128 GB 256 GB 512 GB
4	QR code	Includes part number and serial number

For more information about product features, specifications, options, configurations, and compatibility, see the product QuickSpecs on the Hewlett Packard Enterprise website (<https://www.hpe.com/support/persistentmemoryQS>).

## Processor, heatsink, and socket components

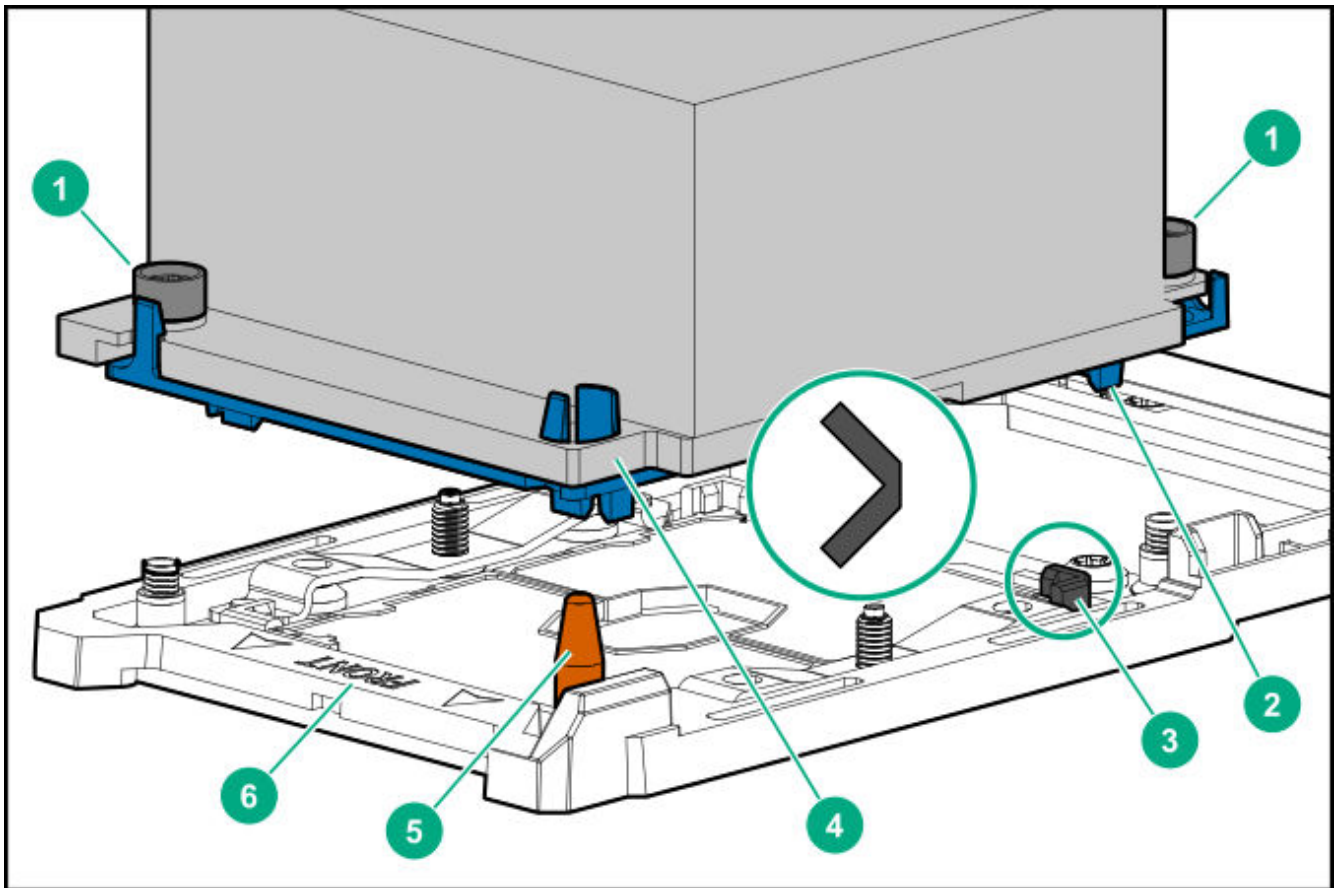

Item	Description
1	Heatsink nuts
2	Processor carrier
3	Pin 1 indicator $\frac{1}{-}$
4	Heatsink guide/keying feature
5	Alignment post
6	Heatsink keying frame

$\frac{1}{-}$  Symbol also on the processor and frame.

# Device numbers

## 8 SFF device bay numbering



## 8 SFF + 2 SFF device bay numbering

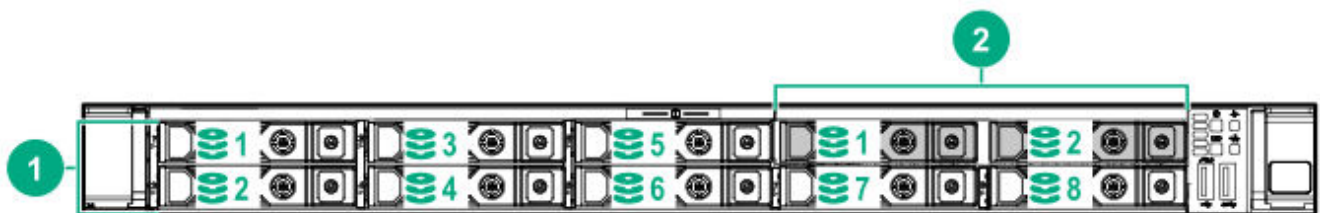

Item	Description
1	Box 1, bays 1-8
2	Box 2, bays 1 and 2

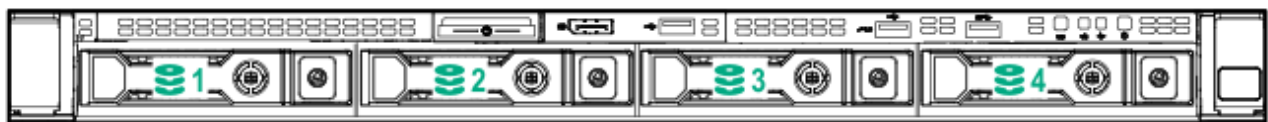

### 10 SFF NVMe/SAS backplane option device bay numbering

When the 10 SFF NVMe/SAS backplane option is installed, NVMe drives must be installed in bays 9 and 10. The other bays support a mix of NVMe and SAS drives.



### Optional rear device bay numbering

The optional rear device bay supports either 1 SFF drive in a SmartDrive carrier, or 2 uFF M.2 drives in an HPE Smart Carrier M.2 (SCM).

When the HPE SFF Flash Adapter is installed, the uFF drives are recognized as 1 and 101.

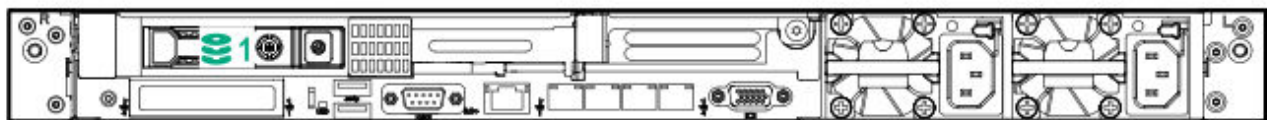

## Hot-plug drive LED definitions

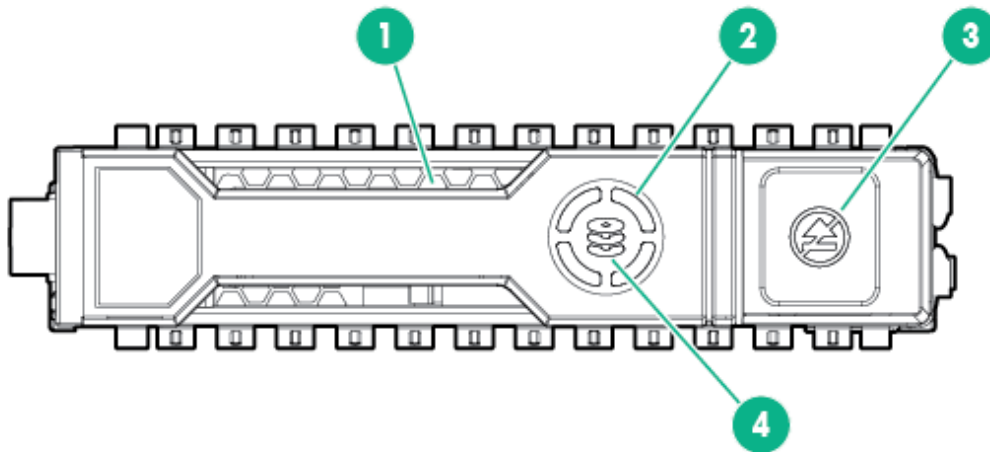

Item	LED	Status	Definition
1	Locate	Solid blue	The drive is being identified by a host application.
		Flashing blue	The drive carrier firmware is being updated or requires an update.
2	Activity ring	Rotating green	Drive activity.
		Off	No drive activity.
3	Do not remove	Solid white	Do not remove the drive. Removing the drive causes one or more of the logical drives to fail.
		Off	Removing the drive does not cause a logical drive to fail.
4	Drive status	Solid green	The drive is a member of one or more logical drives.
		Flashing green	The drive is doing one of the following: <ul style="list-style-type: none"> <li>• Rebuilding</li> <li>• Performing a RAID migration</li> <li>• Performing a strip size migration</li> <li>• Performing a capacity expansion</li> <li>• Performing a logical drive extension</li> <li>• Erasing</li> <li>• Spare part activation</li> </ul>

Item	LED	Status	Definition
		Flashing amber/green	The drive is a member of one or more logical drives and predicts the drive will fail.
		Flashing amber	The drive is not configured and predicts the drive will fail.
		Solid amber	The drive has failed.
		Off	The drive is not configured by a RAID controller or a spare drive.

## Smart Carrier NVMe (SCN) drive LED definitions

The NVMe drive is a PCIe bus device. A device attached to a PCIe bus cannot be removed without allowing the device and bus to complete and cease the signal/traffic flow.



**CAUTION:** Do not remove an NVMe drive from the drive bay while the Do not remove LED is flashing. The Do not remove LED flashes to indicate that the device is still in use. Removing the NVMe drive before the device has completed and ceased signal/traffic flow can cause loss of data.

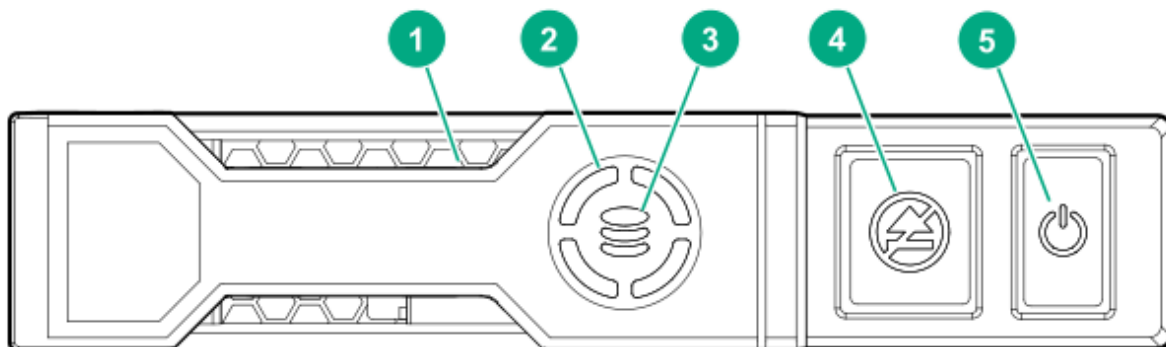

Item	LED	Status	Definition
1	Locate	Solid blue	The drive is being identified by a host application.
		Flashing blue	The drive carrier firmware is being updated or requires an update.

Item	LED	Status	Definition
2	Activity ring	Rotating green	Drive activity
		Off	No drive activity
3	Drive status	Solid green	The drive is a member of one or more logical drives.
		Flashing green	The drive is doing one of the following: <ul style="list-style-type: none"> <li>• Rebuilding</li> <li>• Performing a RAID migration</li> <li>• Performing a stripe size migration</li> <li>• Performing a capacity expansion</li> <li>• Performing a logical drive extension</li> <li>• Erasing</li> </ul>
		Flashing amber/green	The drive is a member of one or more logical drives and predicts the drive will fail.
		Flashing amber	The drive is not configured and predicts the drive will fail.
		Solid amber	The drive has failed.
Off	The drive is not configured by a RAID controller.		
4	Do not remove	Solid white	Do not remove the drive. The drive must be ejected from the PCIe bus prior to removal.
		Flashing white	The drive ejection request is pending.
		Off	The drive has been ejected.
5	Power	Solid green	Do not remove the drive. The drive must be ejected from the PCIe bus prior to removal.
		Flashing green	The drive ejection request is pending.
		Off	The drive has been ejected.

## HPE Basic Drive LED definitions

### LFF low-profile drive carrier

The LFF low-profile drive carrier supports hot-plug SAS and SATA drives.

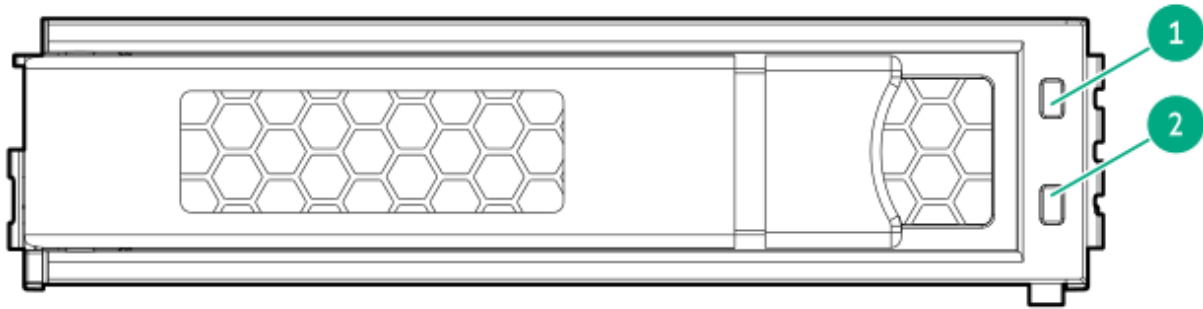

### SFF basic drive carrier

The SFF basic drive carrier supports hot-plug SAS, SATA, and NVMe drives.

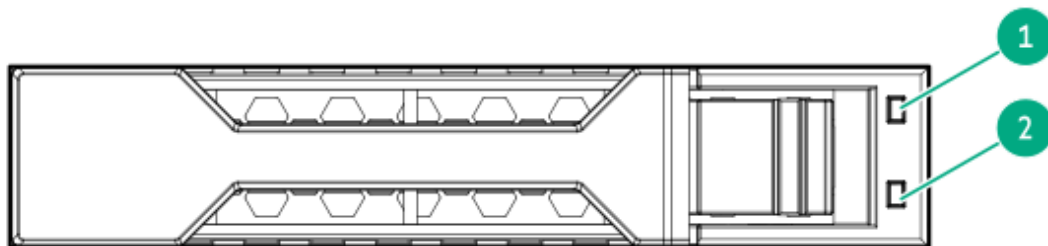

Item	LED	Status	Definition
1	Fault/Locate	Solid amber	This drive has failed, is unsupported, or is invalid.
		Solid blue	The drive is operating normally and being identified by a management application.
		Flashing amber/blue (1 flash per second)	The drive has failed, or a predictive failure alert has been received for this drive. The drive has also been identified by a management application.
		Flashing amber (1 flash per second)	A predictive failure alert has been received for this drive. Replace the drive as soon as possible.
2	Online/Activity	Solid green	The drive is online and has no activity.

Item	LED	Status	Definition
		Flashing green (1 flash per second)	<p>The drive is doing one of the following:</p> <ul style="list-style-type: none"> <li>• Rebuilding or performing a RAID</li> <li>• Performing a stripe size migration</li> <li>• Performing a capacity expansion</li> <li>• Performing a logical drive extension</li> <li>• Erasing</li> <li>• Spare part activation</li> </ul>
		Flashing green (4 flashes per second)	The drive is operation normally and has activity.
		Off	The drive is not configured by a RAID controller or is a spare drive.

## uFF drive components and LEDs

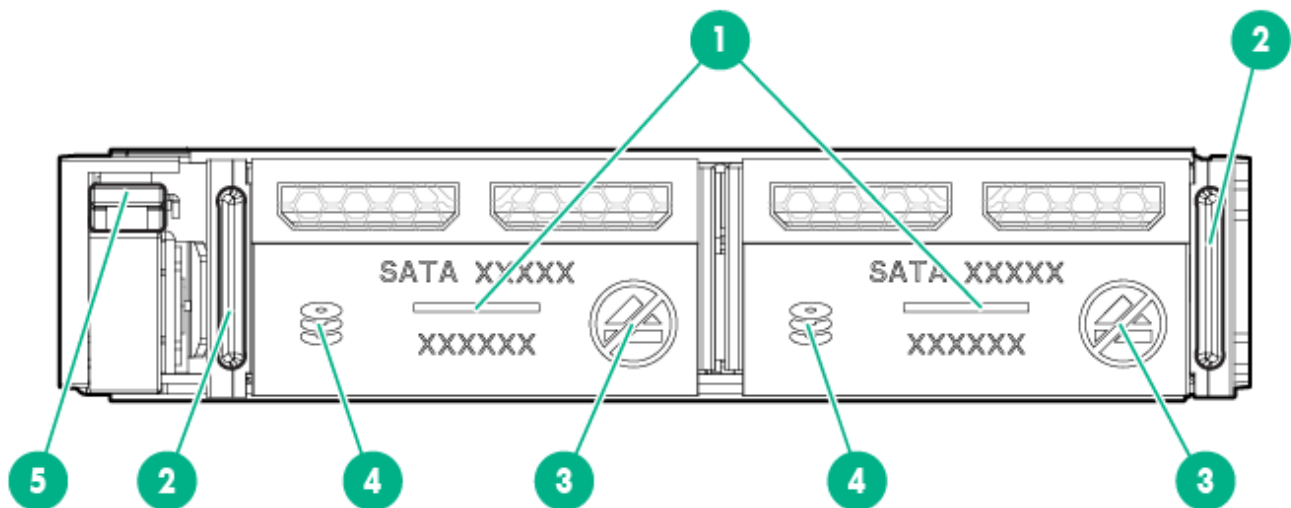

Item	Description	Status
1	Locate	<ul style="list-style-type: none"> <li>• Off—Normal</li> </ul>

Item	Description	Status
		<ul style="list-style-type: none"> <li>• Solid blue—The drive is being identified by a host application</li> <li>• Flashing blue—The drive firmware is being updated or requires an update</li> </ul>
2	uFF drive ejection latch	Removes the uFF drive when released
3	Do not remove LED	<ul style="list-style-type: none"> <li>• Off—OK to remove the drive. Removing the drive does not cause a logical drive to fail.</li> <li>• Solid white—Do not remove the drive. Removing the drive causes one or more of the logical drives to fail.</li> </ul>
4	Drive status LED	<ul style="list-style-type: none"> <li>• Off—The drive is not configured by a RAID controller</li> <li>• Solid green—The drive is a member of one or more logical drives</li> <li>• Flashing green (4 Hz)—The drive is operating normally and has activity</li> <li>• Flashing green (1 Hz)—The drive is rebuilding or performing a RAID migration, stripe size migration, capacity expansion, logical drive extension, or is erasing</li> <li>• Flashing amber/green (1 Hz)—The drive is a member of one or more logical drives that predicts the drive will fail</li> <li>• Solid amber—The drive has failed</li> <li>• Flashing amber (1 Hz)—The drive is not configured and predicts the drive will fail</li> </ul>
5	Adapter ejection release latch and handle	Removes the SFF flash adapter when released

## Hot-plug fans



**CAUTION:** To avoid damage to server components, fan blanks must be installed in fan bays 1 and 2 in a single-processor configuration.



**CAUTION:** To avoid damage to the equipment, do not operate the server for extended periods of time if the server does not have the optimal number of fans installed. Although the server might boot, Hewlett Packard Enterprise does not recommend operating the server without the required fans installed and operating.

The valid fan configurations are listed in the following tables.

### One-processor configuration

Fan bay 1	Fan bay 2	Fan bay 3	Fan bay 4	Fan bay 5	Fan bay 6	Fan bay 7
Fan blank	Fan blank	Fan	Fan	Fan	Fan	Fan

### Two-processor configuration

Fan bay 1	Fan bay 2	Fan bay 3	Fan bay 4	Fan bay 5	Fan bay 6	Fan bay 7
Fan	Fan	Fan	Fan	Fan	Fan	Fan

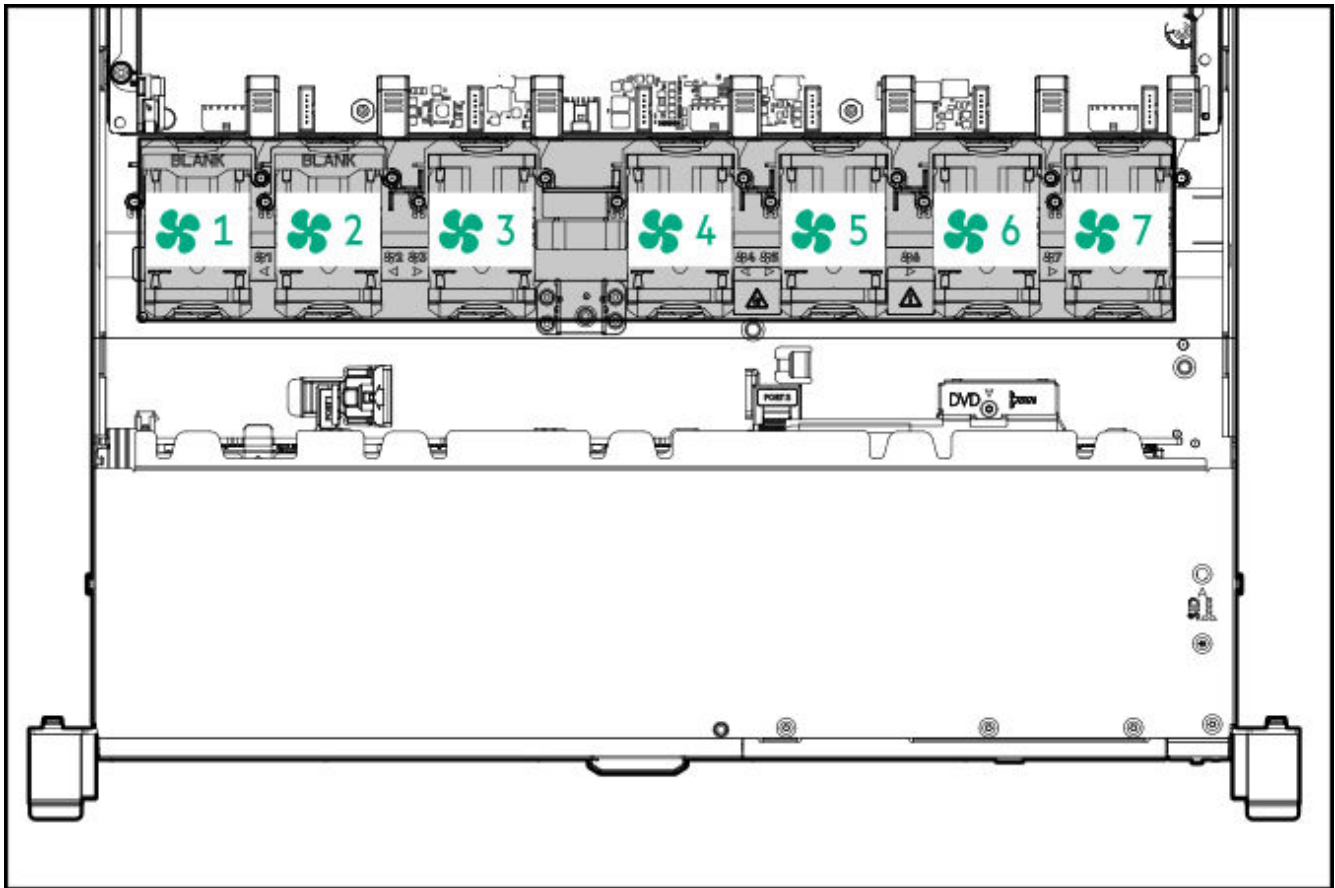

The loss of a single fan rotor (one standard fan) causes loss of redundancy. The loss of two fan rotors (two standard fans or one high performance fan) causes the server to initiate a shutdown.

The high performance fans are required for some drive configurations. They are also required for ASHRAE-compliant configurations. For more information on ASHRAE-compliant configurations, see the Hewlett Packard Enterprise website <https://www.hpe.com/support/ASHRAEGen10>.

The server supports variable fan speeds. The fans operate at minimum speed until a temperature change requires a fan speed increase to cool the server. The server shuts down during the following temperature-related scenarios:

- At POST and in the OS, iLO performs an orderly shutdown if a cautionary temperature level is detected. If the server hardware detects a critical temperature level before an orderly shutdown occurs, the server performs an immediate shutdown.
- When the Thermal Shutdown feature is disabled in the BIOS/Platform Configuration (RBSU), iLO does not perform an orderly shutdown when a cautionary temperature level is detected. Disabling this feature does not disable the server hardware from performing an immediate shutdown when a critical temperature level is detected.



**CAUTION:** A thermal event can damage server components when the Thermal Shutdown feature is disabled in the BIOS/Platform Configuration (RBSU).

# HPE Smart Array P824i-p MR Gen10 Controller

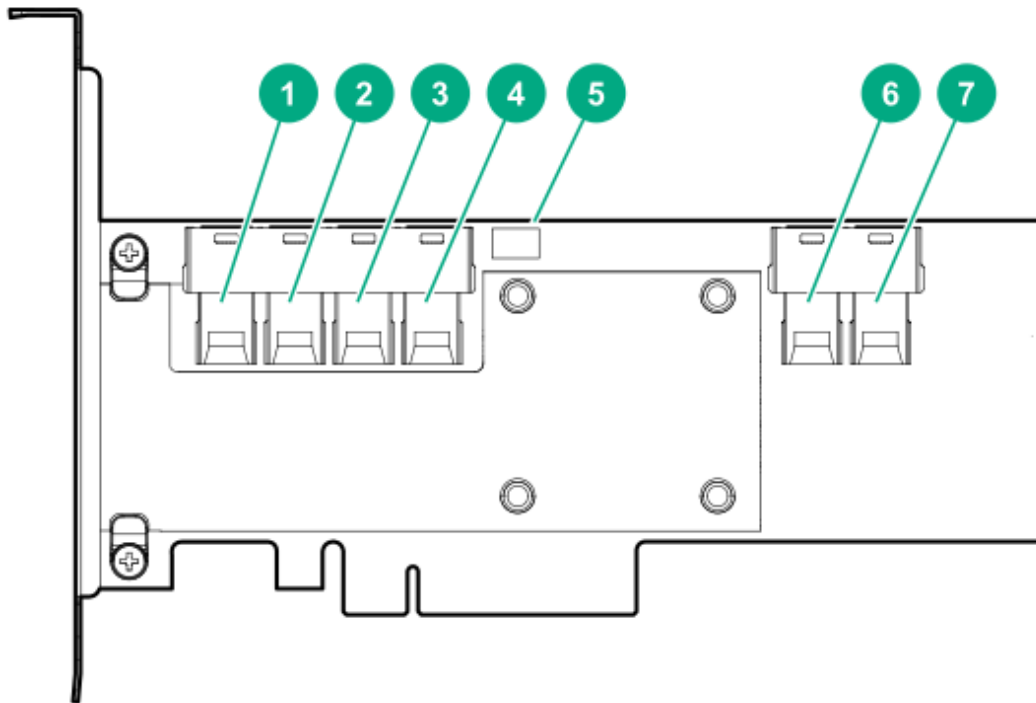

## Components

Item	Description
1	Internal SAS port 1i
2	Internal SAS port 2i
3	Internal SAS port 3i
4	Internal SAS port 4i
5	Controller backup power cable connector
6	Internal SAS port 5i
7	Internal SAS port 6i

## HPE NS204i-p NVMe OS Boot Device components

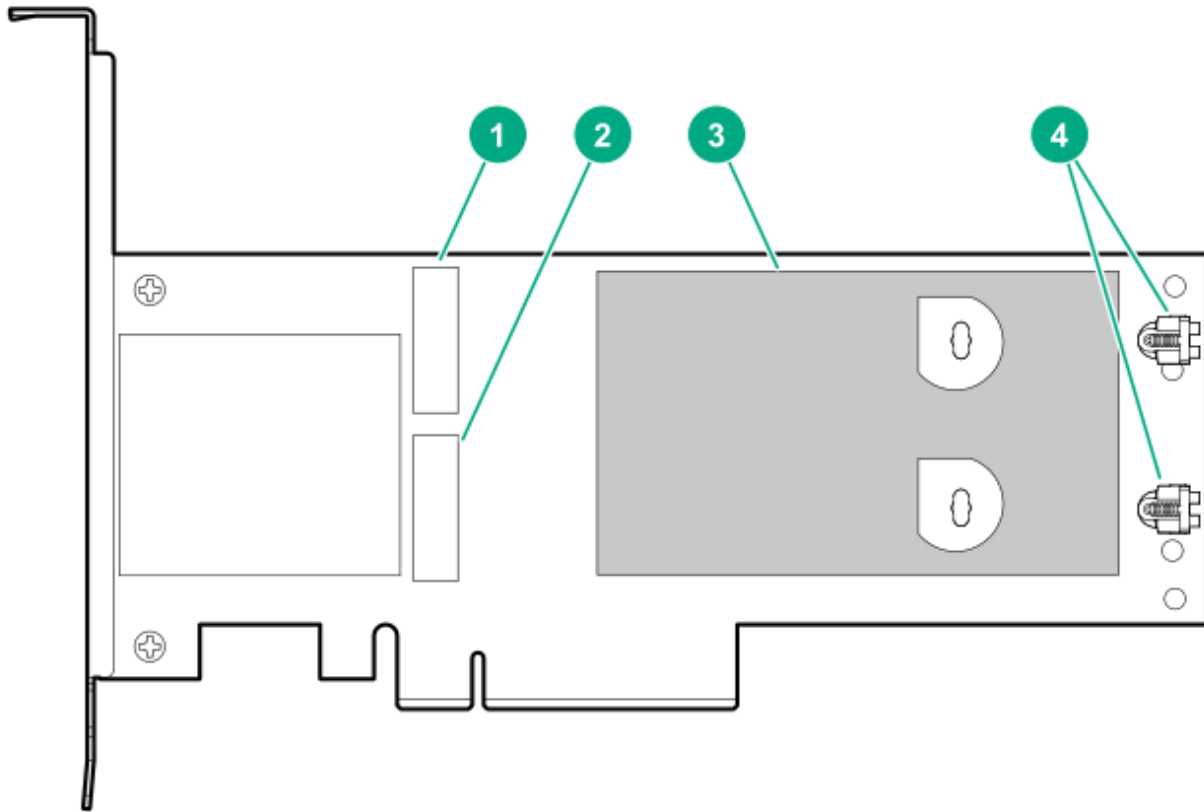

Item	Description
1	Drive bay 1
2	Drive bay 2
3	Thermal interface pad with removable liner
4	M.2 drive retaining latches

## HPE NS204i-p NVMe OS Boot Device LED definitions

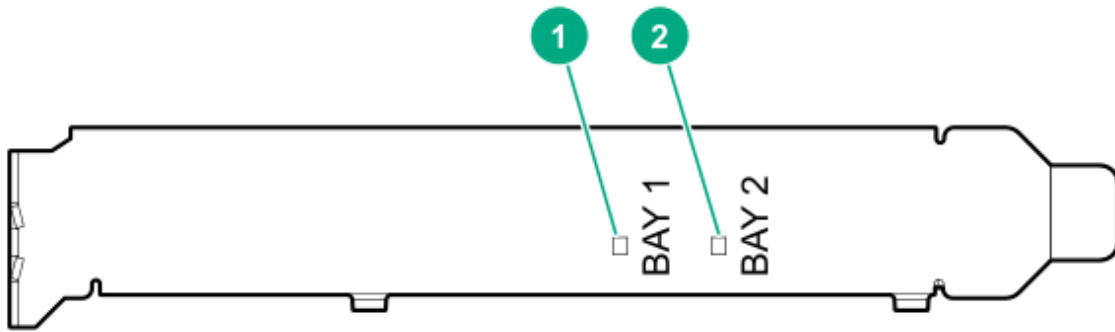

Item	Description	Fault LED status
1	Bay 1 LED	Off: Normal
2	Bay 2 LED	Flashing 1Hz: Drive predictive failure Amber: Drive failure

## HPE InfiniBand HDR/Ethernet 940QSFP 56x16 adapter LEDs

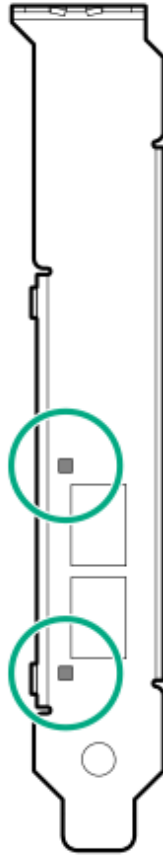

### Link LED status <sup>1</sup>

### Description

Link LED status <sup>1</sup>	Description
Off	A link has not been established.
Solid amber	Active physical link exists
Blinking amber	4 Hz blinking amber indicates a problem with the physical link.
Solid green	A valid logical (data activity) link exists with no active traffic.
Blinking green	A valid logical link exists with active traffic.

<sup>1</sup> 2-port adapter LEDs are shown. The 1-port adapters have only a single LED.

# DSC-25 2-port SFP28 card ports and LEDs

## Ports

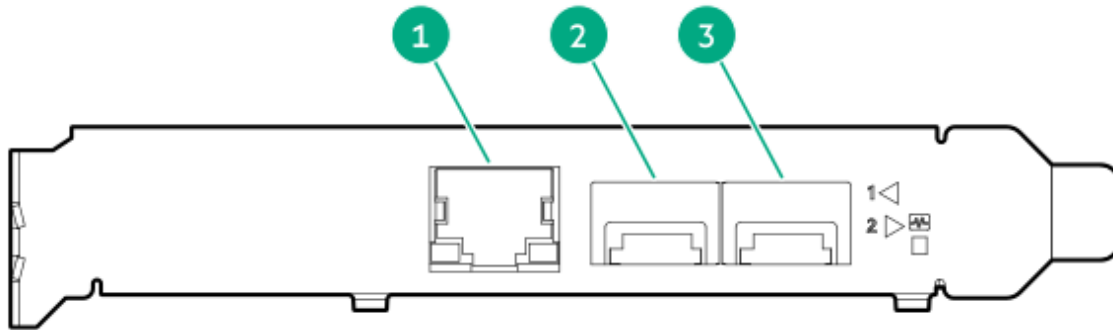
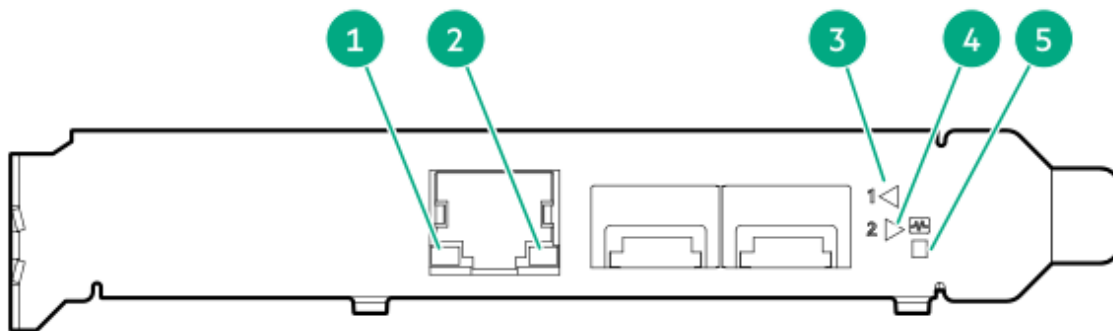

Table 1. Ports

Item	Port	Description
1	Management port	1GbE RJ45
2	Network interface port	10/25G SFP+ based
3	Network interface port	10/25G SFP+ based

## LEDs

The HPE for Pensando DSP DSC-25 2p SFP28 card is a dual-port, single-slot, half-height, half-length (HHHL) SFP28 network adapter. It has LEDs for Link (L) and Activity (A) for each port. A half-height bracket is shown in the following illustration with SFP28 ports and LEDs.



**Table 2. LED indicators**

<b>Item</b>	<b>LED</b>	<b>Status</b>	<b>Description</b>
1	Management Port Activity LED	Off	No activity
		Flashing	Passing traffic; flashing frequency indicates traffic intensity
2	Management Port Link LED	Off	A link has not been established
		Solid green	Valid Ethernet link
3	SFP Port 1 Link/Activity LED	Off	A link has not been established
		Solid green	Valid Ethernet link
		Flashing green	Passing traffic; flashing frequency indicates traffic intensity
		Solid amber	Link fault
4	SFP Port 2 Link/Activity LED	Off	A link has not been established
		Solid green	Valid Ethernet link
		Flashing green	Passing traffic; flashing frequency indicates traffic intensity
		Solid amber	Link fault
5	System status LED	Off	System is not powered
		Solid amber	Power is up, software has not booted yet
		Solid green	System is up and fully operational

## Operations

### Subtopics

**[Power up the server](#)**

**[Power down the server](#)**

**[Extend the server from the rack](#)**

**[Remove the server from the rack](#)**

**Remove the access panel**

**Install the access panel**

**Remove the hot-plug fan**

**Remove the primary PCI riser cage**

**Install the primary PCI riser cage**

**Remove the secondary PCI riser cage**

**Install the secondary PCI riser cage**

**Remove the 8 SFF drive backplane**

**Release the cable management arm**

## Power up the server

### About this task

To power up the server, use one of the following methods:

- Press the Power On/Standby button.
- Use the virtual power button through iLO.

## Power down the server

Before powering down the server for any upgrade or maintenance procedures, perform a backup of critical server data and programs.



### **IMPORTANT:**

When the server is in standby mode, auxiliary power is still being provided to the system.

To power down the server, use one of the following methods:

- Press and release the Power On/Standby button.  
This method initiates a controlled shutdown of applications and the OS before the server enters standby mode.
- Press and hold the Power On/Standby button for more than 4 seconds to force the server to enter standby mode.  
This method forces the server to enter standby mode without properly exiting applications and the OS. If an application stops responding, you can use this method to force a shutdown.

- Use a virtual power button selection through iLO .  
This method initiates a controlled remote shutdown of applications and the OS before the server enters standby mode.

Before proceeding, verify that the server is in standby mode by observing that the system power LED is amber.

## Extend the server from the rack

### About this task



#### NOTE:

If the cable management arm option is installed, you can extend the server without powering down the server or disconnecting peripheral cables and power cords. These steps are only necessary with the standard cable management solution.

### Procedure

1. Power down the server.
2. Disconnect all peripheral cables and power cords.
3. Loosen the front panel thumbscrews.
4. Extend the server on the rack rails until the server rail-release latches engage.



#### WARNING:

To reduce the risk of personal injury or equipment damage, be sure that the rack is adequately stabilized before extending a component from the rack.



#### WARNING:

To reduce the risk of personal injury, be careful when pressing the server rail-release latches and sliding the server into the rack. The sliding rails could pinch your fingers.

5. After the installation or maintenance procedure, slide the server into the rack:
  - a. Slide the server fully into the rack.
  - b. Secure the server by tightening the thumbscrews.

6. Connect the peripheral cables and power cords.

## Remove the server from the rack

### Prerequisites

Before you perform this procedure, review the:

- 
- 

### Procedure

1. Power down the server.
2. Extend the server from the rack.
3. Disconnect the cabling and remove the server from the rack. For more information, see the documentation that ships with the rack mounting option.
4. Place the server on a sturdy, level surface.

## Remove the access panel

### About this task



**WARNING:** To reduce the risk of personal injury from hot surfaces, allow the drives and the internal system components to cool before touching them.



**CAUTION:** Do not operate the server for long periods with the access panel open or removed. Operating the server in this manner results in improper airflow and improper cooling that can lead to thermal damage.

### Procedure

1. Power down the server.
2. Extend the server from the rack.

3. Open or unlock the locking latch, slide the access panel to the rear of the chassis, and remove the access panel.

## Install the access panel

### Procedure

1. Place the access panel on top of the server with the latch open.

Allow the panel to extend past the rear of the server approximately 1.25 cm (0.5 in).

2. Push down on the latch.

The access panel slides to a closed position.

3. Tighten the security screw on the latch, if needed.

## Remove the hot-plug fan

### Procedure

1. Observe the following alert:



**IMPORTANT:** After removing a high-performance (dual-rotor) fan, install or replace the fan within 60 seconds. Otherwise, the server will shut down gracefully.

2. Do one of the following:
  - a. Extend the server from the rack ([Extend the server from the rack](#)).
  - b. Remove the server from the rack ([Remove the server from the rack](#)).
3. Remove the access panel ([Remove the access panel](#)).
4. Remove the fan.

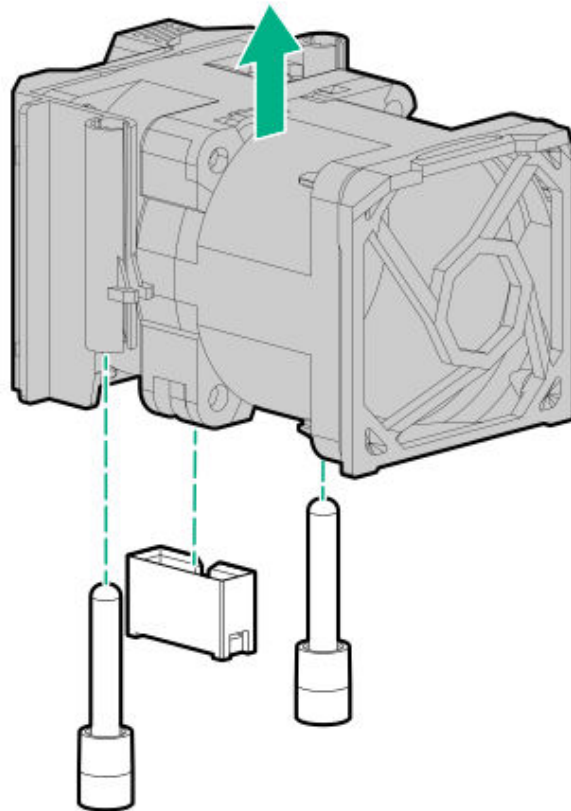
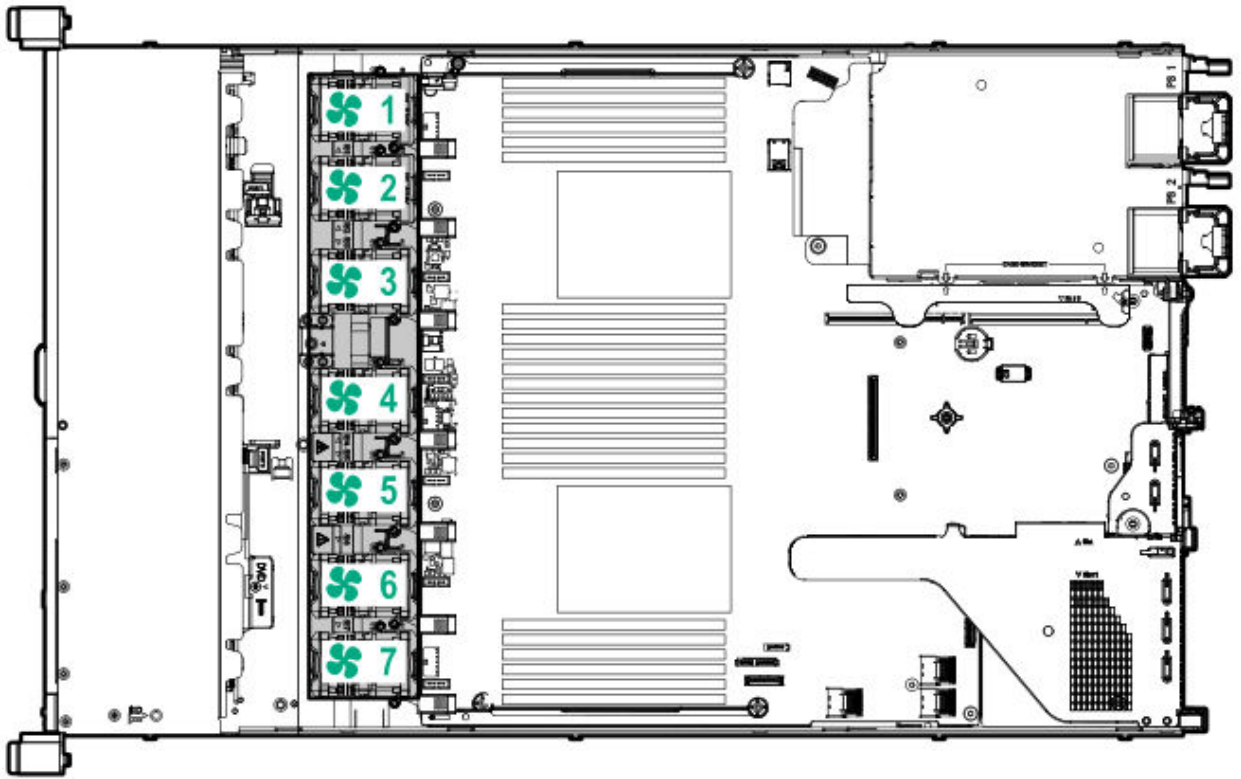



**CAUTION:** Do not operate the server for long periods with the access panel open or removed. Operating the server in this manner results in improper airflow and improper cooling that can lead to thermal damage.



**IMPORTANT:** For optimum cooling, install fans in all primary fan locations.

## Results

To replace the component, reverse the removal procedure.

# Remove the primary PCI riser cage

## About this task



**CAUTION:** To prevent damage to the server or expansion boards, power down the server and remove all AC power cords before removing or installing the PCI riser cage.

## Procedure

1. Back up all server data.
2. Power down the server ([Power down the server](#)).
3. Remove all power:
  - a. Disconnect each power cord from the power source.
  - b. Disconnect each power cord from the server.
4. Do one of the following:
  - a. Extend the server from the rack ([Extend the server from the rack](#)).
  - b. Remove the server from the rack ([Remove the server from the rack](#)).
5. Remove the access panel ([Remove the access panel](#)).
6. Remove the PCI riser cage.

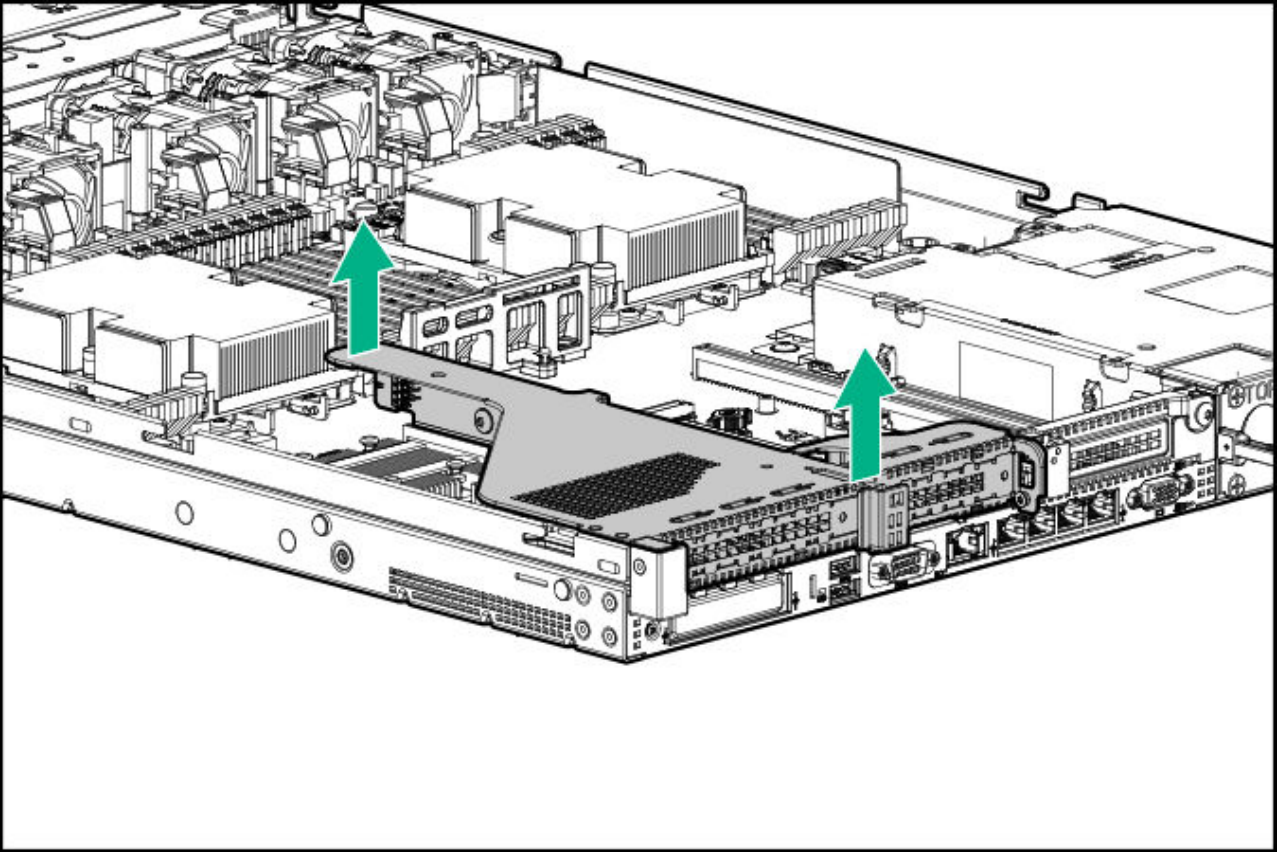

## Install the primary PCI riser cage

### Procedure

1. Install the PCI riser cage.

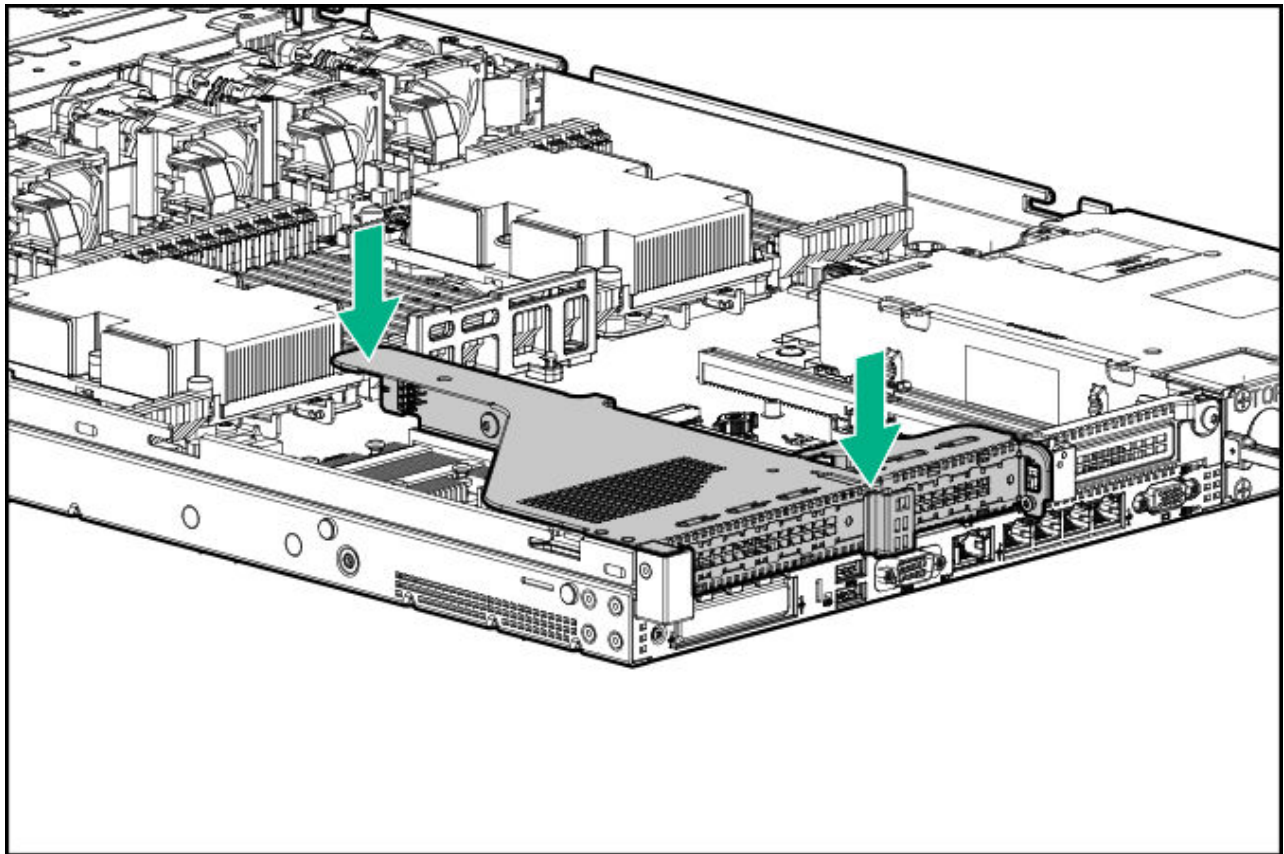

2. Install the access panel ([Install the access panel](#)).
3. Install the server into the rack ([#GUID-D335199C-041B-4BE2-B1EB-A302EF71D53E](#)).
4. Connect each power cord to the server.
5. Connect each power cord to the power source.
6. Power up the server ([Power up the server](#)).

## Remove the secondary PCI riser cage

### Procedure

1. Observe the following alert:



**CAUTION:** To prevent damage to the server or expansion boards, power down the server and remove all AC power cords before removing or installing the PCI riser cage.

2. Back up all server data.
3. Power down the server ([Power down the server](#)).
4. Remove all power:
  - a. Disconnect each power cord from the power source.
  - b. Disconnect each power cord from the server.
5. Do one of the following:
  - a. Extend the server from the rack ([Extend the server from the rack](#)).
  - b. Remove the server from the rack ([Remove the server from the rack](#)).
6. Remove the access panel ([Remove the access panel](#)).
7. If needed, remove the primary PCI riser cage ([Remove the primary PCI riser cage](#)).
8. Disconnect any cables connected to the PCI riser cage.
9. Remove any expansion boards installed in the PCI riser cage.

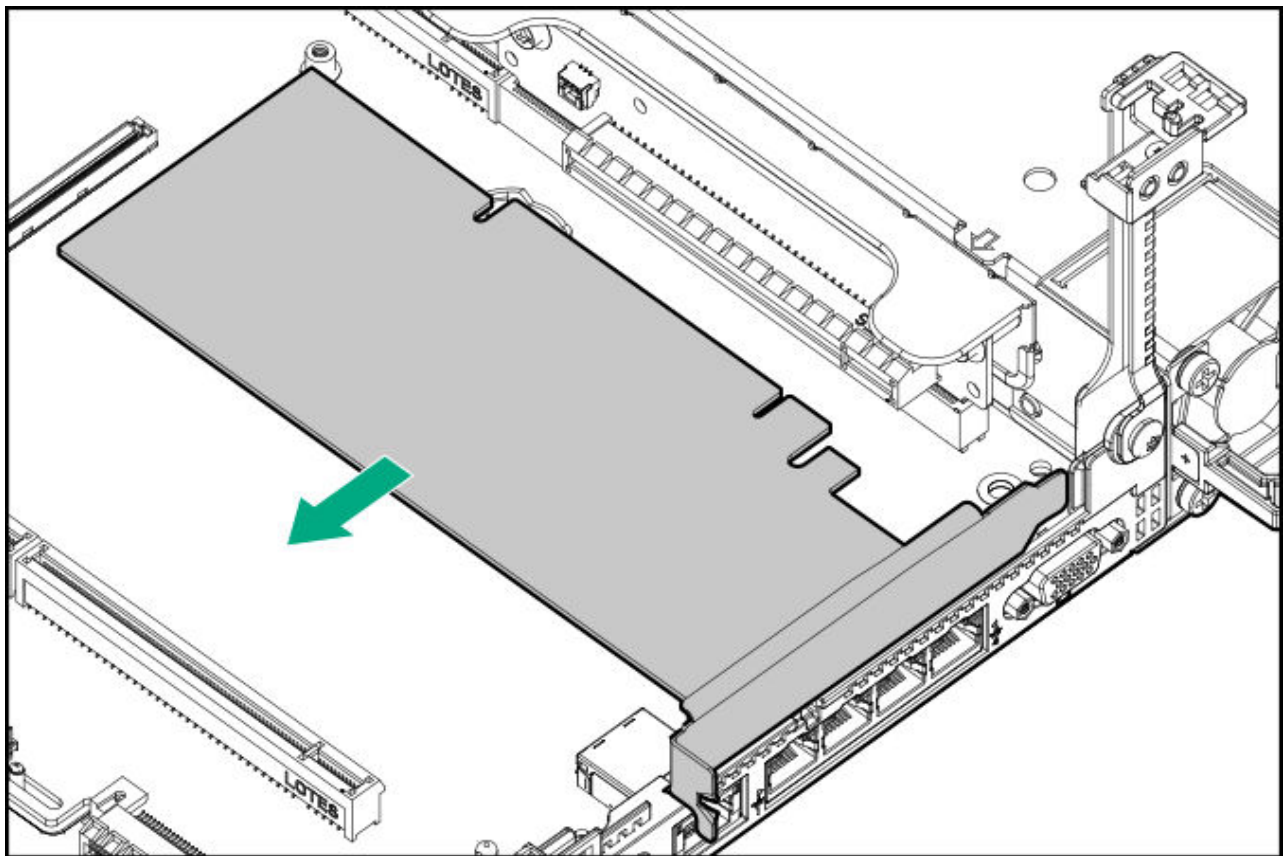

10. Remove the PCI riser cage.

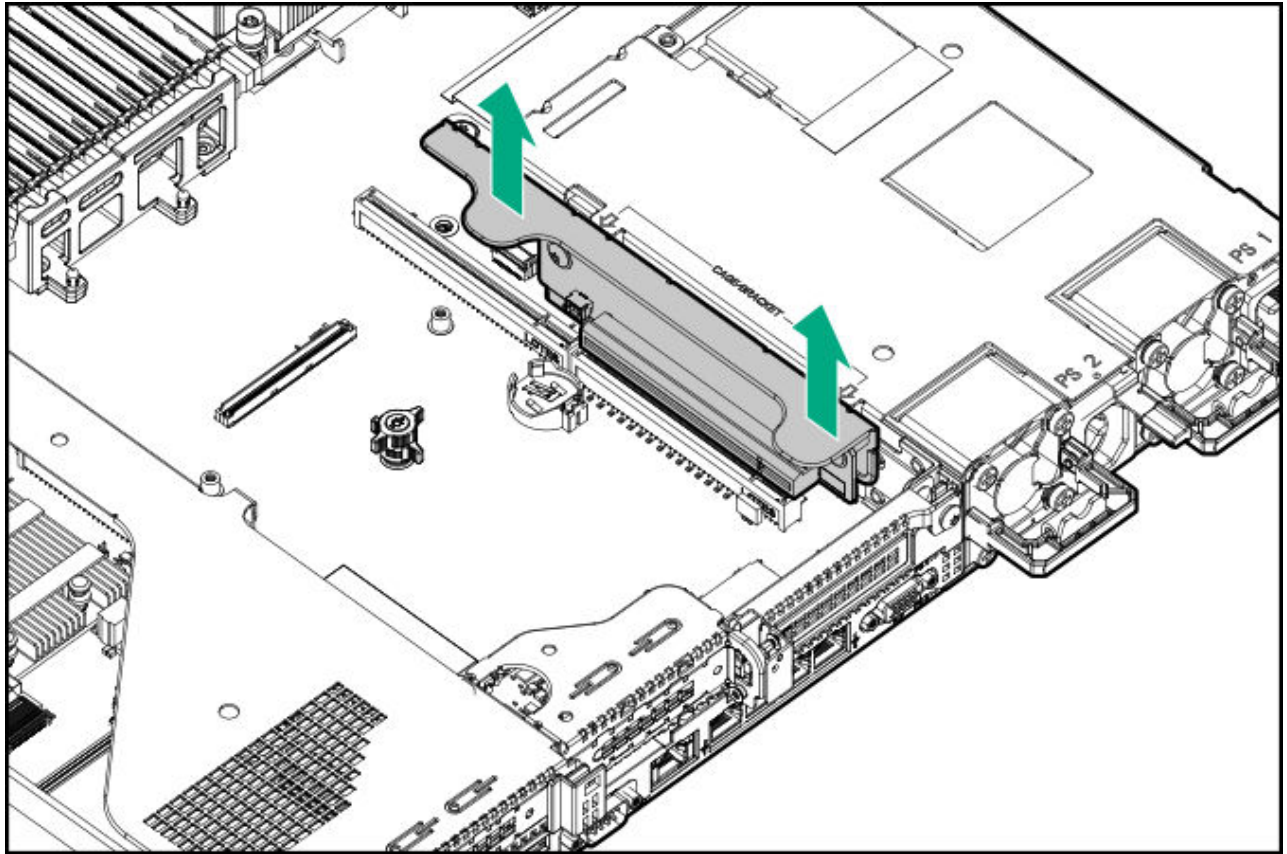

## Install the secondary PCI riser cage

### Procedure

1. Install the PCI riser cage.

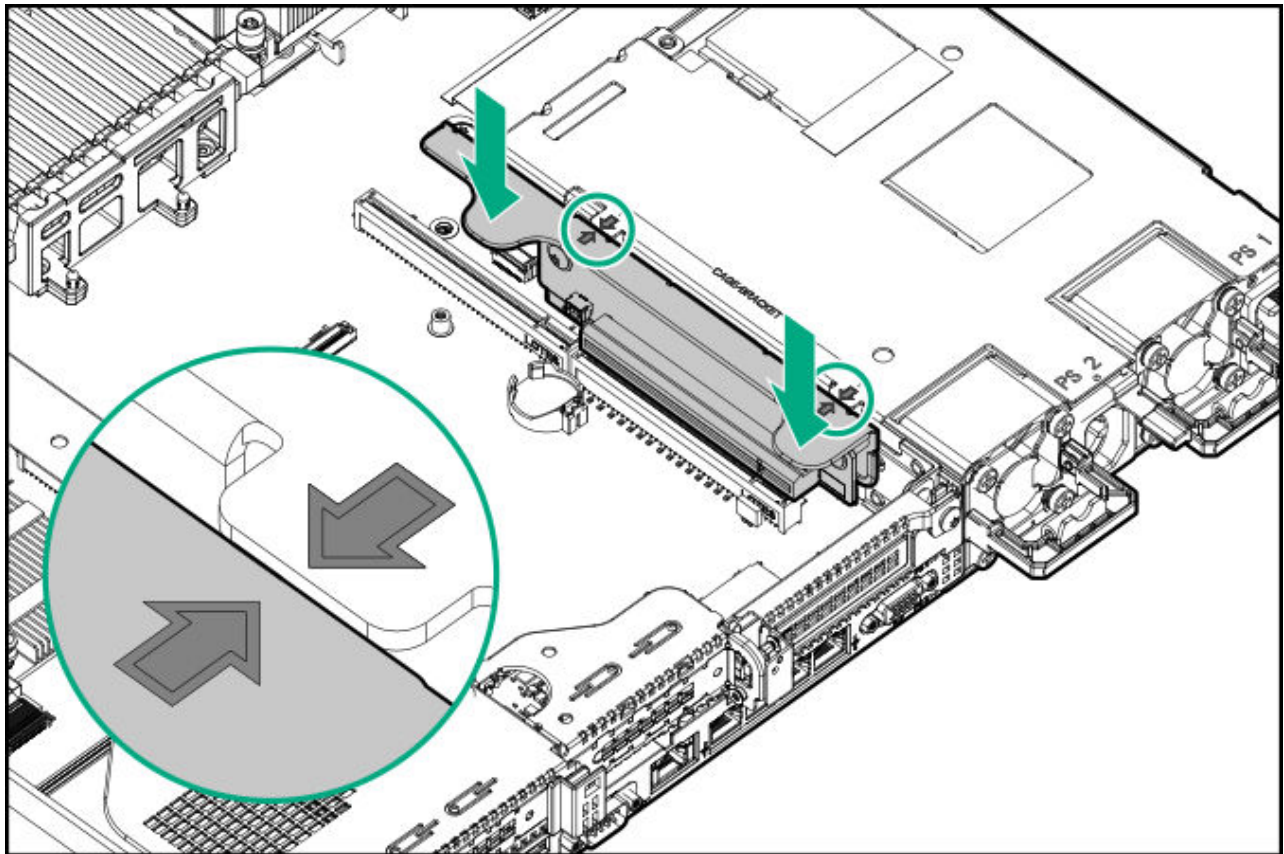

2. If needed, install expansion boards ([Installing an expansion board in the secondary riser cage](#)).
3. Install the access panel ([Install the access panel](#)).
4. Install the server into the rack ([#GUID-D335199C-041B-4BE2-B1EB-A302EF71D53E](#)).
5. Connect each power cord to the server.
6. Connect each power cord to the power source.
7. Power up the server ([Power up the server](#)).

## Remove the 8 SFF drive backplane

### Procedure

1. Back up all server data.
2. Power down the server ([Power down the server](#)).
3. Remove all power:

- a. Disconnect each power cord from the power source.
- b. Disconnect each power cord from the server.
4. Do one of the following:
  - a. Extend the server from the rack (Extend the server from the rack).
  - b. Remove the server from the rack (Remove the server from the rack).
5. Remove the access panel (Remove the access panel).
6. Remove all drives (Removing a hot-plug SAS or SATA hard drive).
7. Disconnect and remove all cables connected to the drive backplane.
8. Remove the 8 SFF SAS/SATA drive backplane.

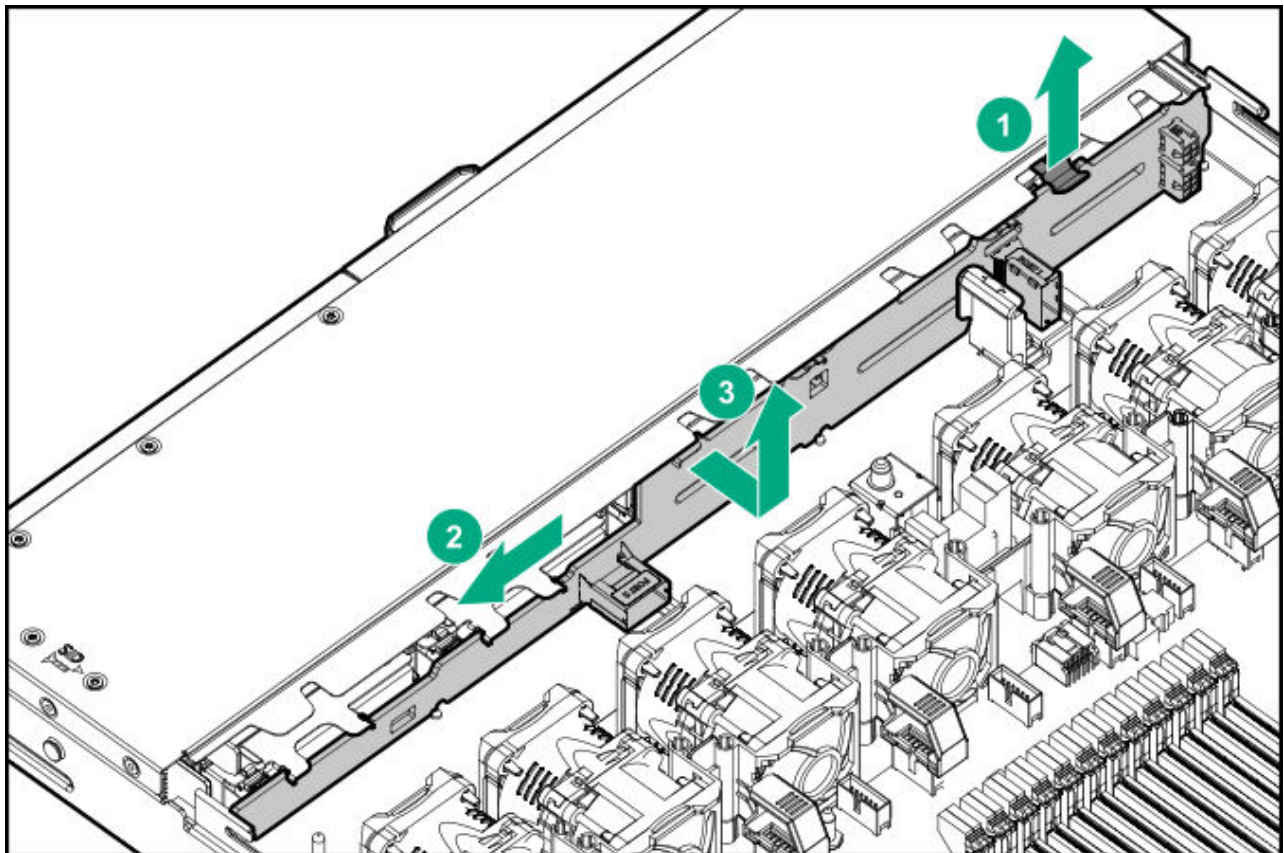

## Release the cable management arm

### About this task

Release the cable management arm and then swing the arm away from the rack.

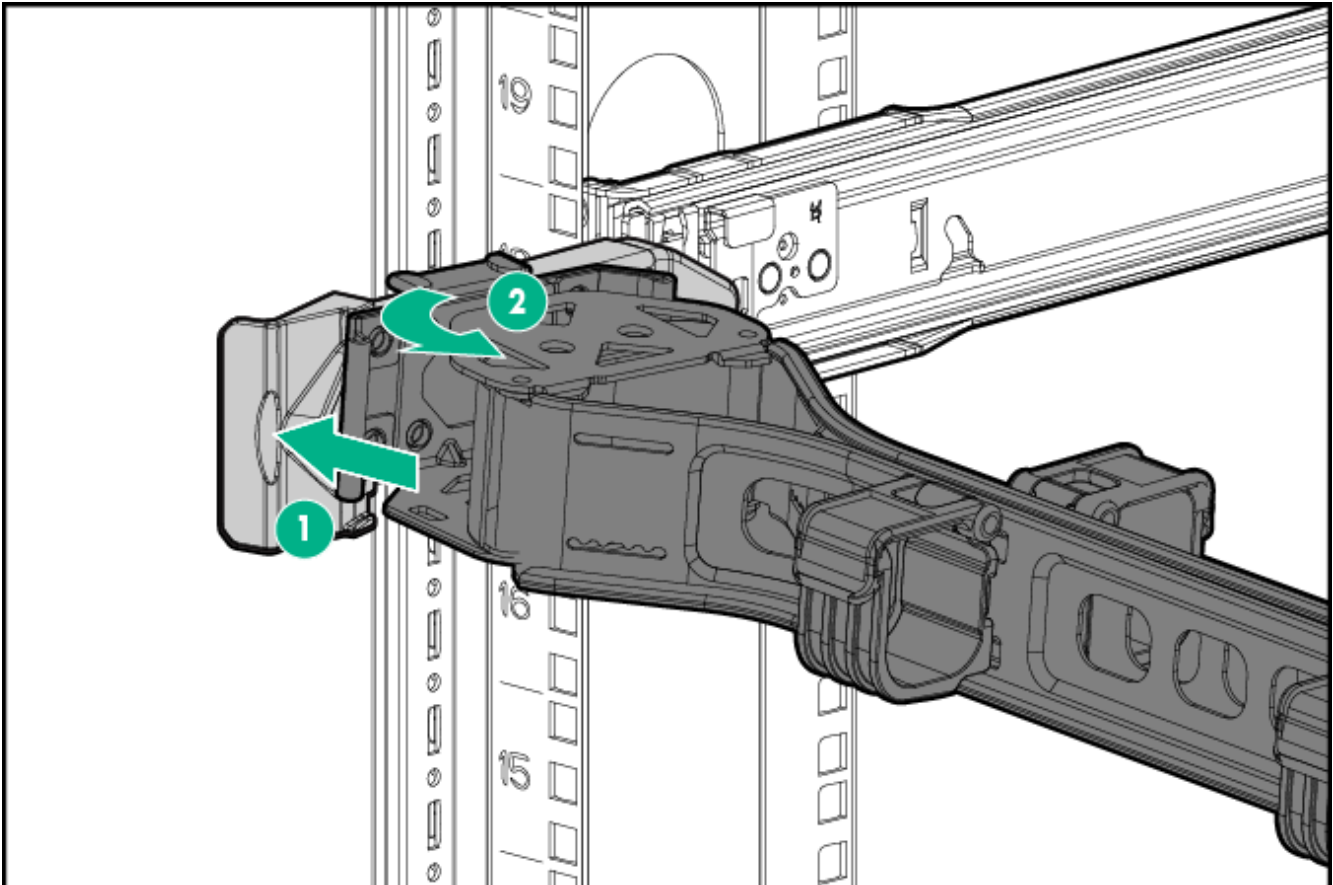

## Setup

### Subtopics

- [Optimum environment](#)
- [Server warnings and cautions](#)
- [Rack warnings](#)
- [Identifying the contents of the server shipping carton](#)
- [Installing hardware options](#)
- [Installing the server in a rack](#)
- [Operating system](#)
- [Selecting boot options in UEFI Boot Mode](#)
- [Selecting boot options](#)

# Optimum environment

When installing the server in a rack, select a location that meets the environmental standards described in this section.

## Subtopics

[Space and airflow requirements](#)

[Temperature requirements](#)

[Power requirements](#)

[Electrical grounding requirements](#)

[Connecting a DC power cable to a DC power source](#)

## Space and airflow requirements

To allow for servicing and adequate airflow, observe the following space and airflow requirements when deciding where to install a rack:

- Leave a minimum clearance of 63.5 cm (25 in) in front of the rack.
- Leave a minimum clearance of 76.2 cm (30 in) behind the rack.
- Leave a minimum clearance of 121.9 cm (48 in) from the back of the rack to the back of another rack or row of racks.

Hewlett Packard Enterprise servers draw in cool air through the front door and expel warm air through the rear door. Therefore, the front and rear rack doors must be adequately ventilated to allow ambient room air to enter the cabinet, and the rear door must be adequately ventilated to allow the warm air to escape from the cabinet.



**CAUTION:** To prevent improper cooling and damage to the equipment, do not block the ventilation openings.

When vertical space in the rack is not filled by a server or rack component, the gaps between the components cause changes in airflow through the rack and across the servers. Cover all gaps with blanking panels to maintain proper airflow.



**CAUTION:** Always use blanking panels to fill empty vertical spaces in the rack. This arrangement ensures proper airflow. Using a rack without blanking panels results in improper cooling that can lead to thermal damage.

The 9000 and 10000 Series Racks provide proper server cooling from flow-through perforations in the front and rear doors that provide 64 percent open area for ventilation.



**CAUTION:** When using a Compaq branded 7000 series rack, install the high airflow rack door insert (PN 327281-B21 for 42U rack, PN 157847-B21 for 22U rack) to provide proper front-to-back airflow and cooling.



**CAUTION:**

If a third-party rack is used, observe the following additional requirements to ensure adequate airflow and to prevent damage to the equipment:

- Front and rear doors—If the 42U rack includes closing front and rear doors, you must allow 5,350 sq cm (830 sq in) of holes evenly distributed from top to bottom to permit adequate airflow (equivalent to the required 64 percent open area for ventilation).
- Side—The clearance between the installed rack component and the side panels of the rack must be a minimum of 7 cm (2.75 in).

## Temperature requirements

To ensure continued safe and reliable equipment operation, install or position the system in a well-ventilated, climate-controlled environment.

The maximum recommended ambient operating temperature (TMRA) for most server products is 35°C (95°F). The temperature in the room where the rack is located must not exceed 35°C (95°F).



**CAUTION:** To reduce the risk of damage to the equipment when installing third-party options:

- Do not permit optional equipment to impede airflow around the server or to increase the internal rack temperature beyond the maximum allowable limits.
- Do not exceed the manufacturer's TMRA.

## Power requirements

Installation of this equipment must comply with local and regional electrical regulations governing the installation of information technology equipment by licensed electricians. This equipment is designed to operate in installations covered by NFPA 70, 1999 Edition (National Electric Code) and NFPA-75, 1992 (Code for Protection of Electronic Computer/Data Processing Equipment). For electrical power ratings on options, refer to the product rating label or the user documentation supplied with that option.



**WARNING:** To reduce the risk of personal injury, fire, or damage to the equipment, do not overload the AC supply branch circuit that provides power to the rack. Consult the electrical authority having jurisdiction over wiring and installation requirements of your facility.



**CAUTION:** Protect the server from power fluctuations and temporary interruptions with a regulating uninterruptible power supply. This device protects the hardware from damage caused by power surges and voltage spikes and keeps the system in operation during a power failure.

## Electrical grounding requirements

The server must be grounded properly for proper operation and safety. In the United States, you must install the equipment in accordance with NFPA 70, National Electric Code Article 250, as well as any local and regional building codes. In Canada, you must install the equipment in accordance with Canadian Standards Association, CSA C22.1, Canadian Electrical Code. In all other countries, you must install the equipment in accordance with any regional or national electrical wiring codes, such as the International Electrotechnical Commission (IEC) Code 364, parts 1 through 7. Furthermore, you must be sure that all power distribution devices used in the installation, such as branch wiring and receptacles, are listed or certified grounding-type devices.

Because of the high ground-leakage currents associated with multiple servers connected to the same power source, Hewlett Packard Enterprise recommends the use of a PDU that is either permanently wired to the building's branch circuit or includes a nondetachable cord that is wired to an industrial-style plug. NEMA locking-style plugs or those complying with IEC 60309 are considered suitable for this purpose. Using common power outlet strips for the server is not recommended.

## Connecting a DC power cable to a DC power source



### **WARNING:**

To reduce the risk of electric shock or energy hazards:

- This equipment must be installed by trained service personnel, as defined by the NEC and IEC 60950-1, Second Edition, the standard for Safety of Information Technology Equipment.
- Connect the equipment to a reliably grounded Secondary circuit source. A Secondary circuit has no direct connection to a Primary circuit and derives its power from a transformer, converter, or equivalent isolation device.
- The branch circuit overcurrent protection must be rated 27 A.



**WARNING:** When installing a DC power supply, the ground wire must be connected before the positive or negative leads.



**WARNING:** Remove power from the power supply before performing any installation steps or maintenance on the power supply.



**CAUTION:** The server equipment connects the earthed conductor of the DC supply circuit to the earthing conductor at the equipment. For more information, see the documentation that ships with the power supply.



**CAUTION:** If the DC connection exists between the earthed conductor of the DC supply circuit and the earthing conductor at the server equipment, the following conditions must be met:

- This equipment must be connected directly to the DC supply system earthing electrode conductor or to a bonding jumper from an earthing terminal bar or bus to which the DC supply system earthing electrode conductor is connected.
- This equipment should be located in the same immediate area (such as adjacent cabinets) as any other equipment that has a connection between the earthed conductor of the same DC supply circuit and the earthing conductor, and also the point of earthing of the DC system. The DC system should be earthed elsewhere.
- The DC supply source is to be located within the same premises as the equipment.

To connect a DC power cable to a DC power source:

1. Cut the DC power cord ends no shorter than 150 cm (59.06 in).
2. If the power source requires ring tongues, use a crimping tool to install the ring tongues on the power cord wires.



**IMPORTANT:** The ring terminals must be UL approved and accommodate 12 gauge wires.



**IMPORTANT:** The minimum nominal thread diameter of a pillar or stud type terminal must be 3.5 mm (0.138 in); the diameter of a screw type terminal must be 4.0 mm (0.157 in).

3. Stack each same-colored pair of wires and then attach them to the same power source. The power cord consists of three wires (black, red, and green).

For more information, see the documentation that ships with the power supply.

## Server warnings and cautions



### **WARNING:**

This server is heavy. To reduce the risk of personal injury or damage to the equipment:

- Observe local occupational health and safety requirements and guidelines for manual material handling.
- Get help to lift and stabilize the product during installation or removal, especially when the product is not fastened to the rails. Hewlett Packard Enterprise recommends that a minimum of two people are required for all rack server installations. If the server is installed higher than chest level, a third person may be required to help align the server.
- Use caution when installing the server in or removing the server from the rack; it is unstable when not fastened to the rails.



### **WARNING:**

To reduce the risk of personal injury from hot surfaces, allow the drives and the internal system components to cool before touching them.



### **WARNING:**

To reduce the risk of personal injury, electric shock, or damage to the equipment, remove the power cord to remove power from the server. The front panel Power On/Standby button does not completely shut off system power. Portions of the power supply and some internal circuitry remain active until AC/DC power is removed.



### **WARNING:**

To reduce the risk of fire or burns after removing the energy pack:

- Do not disassemble, crush, or puncture the energy pack.
- Do not short external contacts.
- Do not dispose of the energy pack in fire or water.
- Do not expose the energy pack to low air pressure as it might lead to explosion or leakage of flammable liquid or gas.
- Do not expose the energy pack to temperatures higher than 60°C (140°F).

## Rack warnings



**WARNING:** To reduce the risk of personal injury or damage to the equipment, be sure that:

- The leveling jacks are extended to the floor.
- The full weight of the rack rests on the leveling jacks.
- The stabilizing feet are attached to the rack if it is a single-rack installation.
- The racks are coupled together in multiple-rack installations.
- Only one component is extended at a time. A rack may become unstable if more than one component is extended for any reason.



**WARNING:** To reduce the risk of personal injury or equipment damage when unloading a rack:

- At least two people are needed to safely unload the rack from the pallet. An empty 42U rack can weigh as much as 115 kg (253 lb), can stand more than 2.1 m (7 ft) tall, and might become unstable when being moved on its casters.
- Never stand in front of the rack when it is rolling down the ramp from the pallet. Always handle the rack from both sides.



**WARNING:**

To reduce the risk of personal injury or damage to the equipment, adequately stabilize the rack before extending a component outside the rack. Extend only one component at a time. A rack may become unstable if more than one component is extended.



**WARNING:**

When installing a server in a telco rack, be sure that the rack frame is adequately secured at the top and bottom to the building structure.

## Identifying the contents of the server shipping carton

Unpack the server shipping carton and locate the materials and documentation necessary for installing the server. All the rack mounting hardware necessary for installing the server into the rack is included with the rack or the server.

The contents of the server shipping carton include:

- Server
- Power cord
- Hardware documentation and software products
- Rack-mounting hardware and documentation

In addition to the supplied items, you might need:

- Operating system or application software
- Hardware options
- Screwdriver

## Installing hardware options

Install any hardware options before initializing the server. For options installation information, refer to the option documentation. For server-specific information, refer to "[Hardware options installation](#)."

## Installing the server in a rack

### About this task

The following rack rails are supported:

- Easy install rail kit
- Ball-bearing rail kit

### Subtopics

**[Installing the server with the easy install rail kit](#)**

**[Installing the server in a rack with the ball-bearing rail kit](#)**

# Installing the server with the easy install rail kit

## Prerequisites



**IMPORTANT:** HPE rail kits are designed to work with HPE racks. Non-HPE racks are not supported. For more information on rack rail compatibility and specifications, see the server QuickSpecs.



### **WARNING:**

To reduce the risk of personal injury or equipment damage, do one of the following:

- During installation, use two or more people to lift and stabilize the product.
- Use a lift that can handle the load of the product.



### **WARNING:**

To reduce the risk of personal injury or equipment damage, be sure that the rack is adequately stabilized before installing the enclosure .



### **CAUTION:**

Always plan the rack installation so that the heaviest item is on the bottom of the rack. Install the heaviest item first, and continue to populate the rack from the bottom to the top.



### **CAUTION:**

Be sure to keep the product parallel to the floor when installing the enclosure . Tilting the product up or down could result in damage to the slides.

For square or round-hole racks:

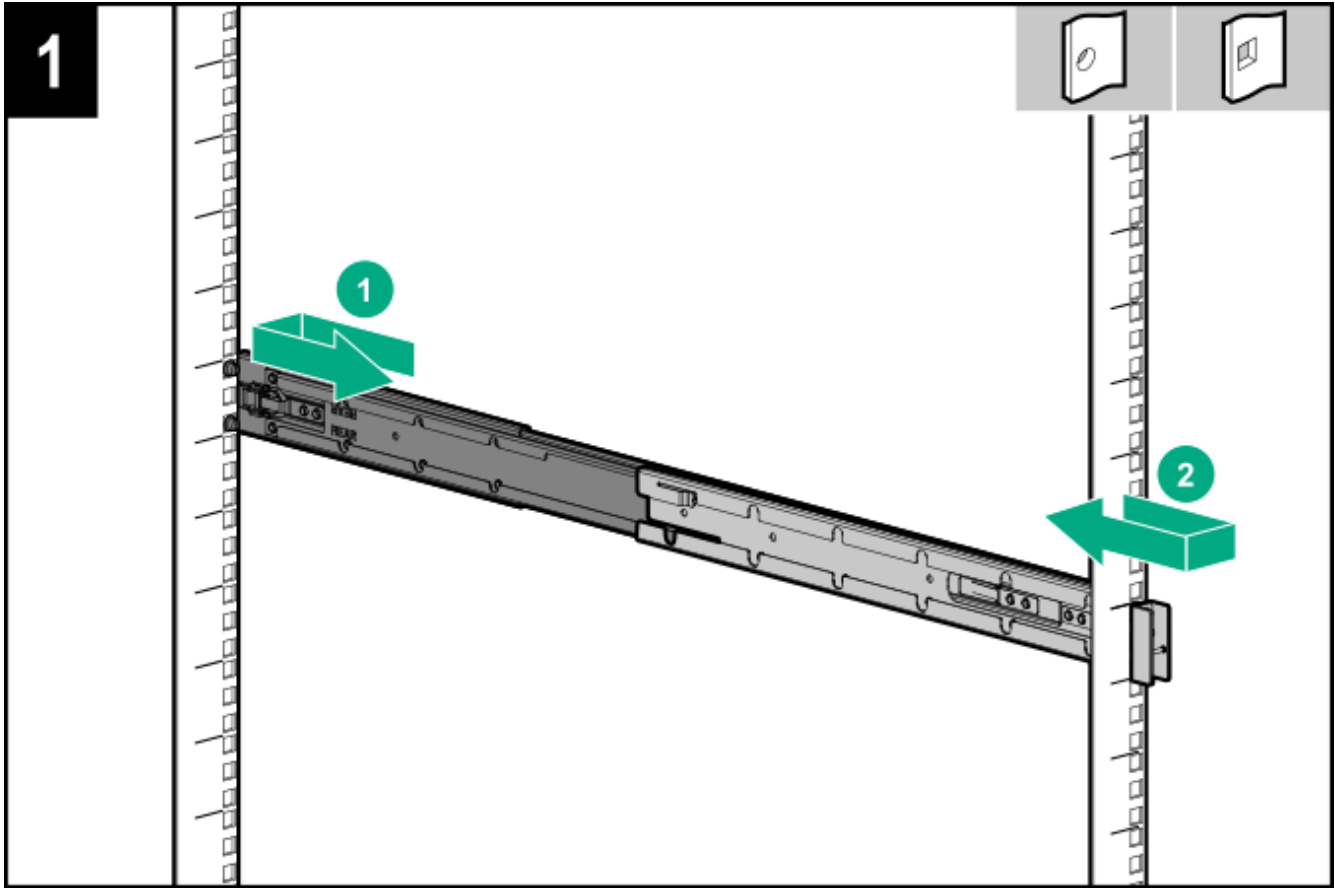

For threaded-hole racks:

1

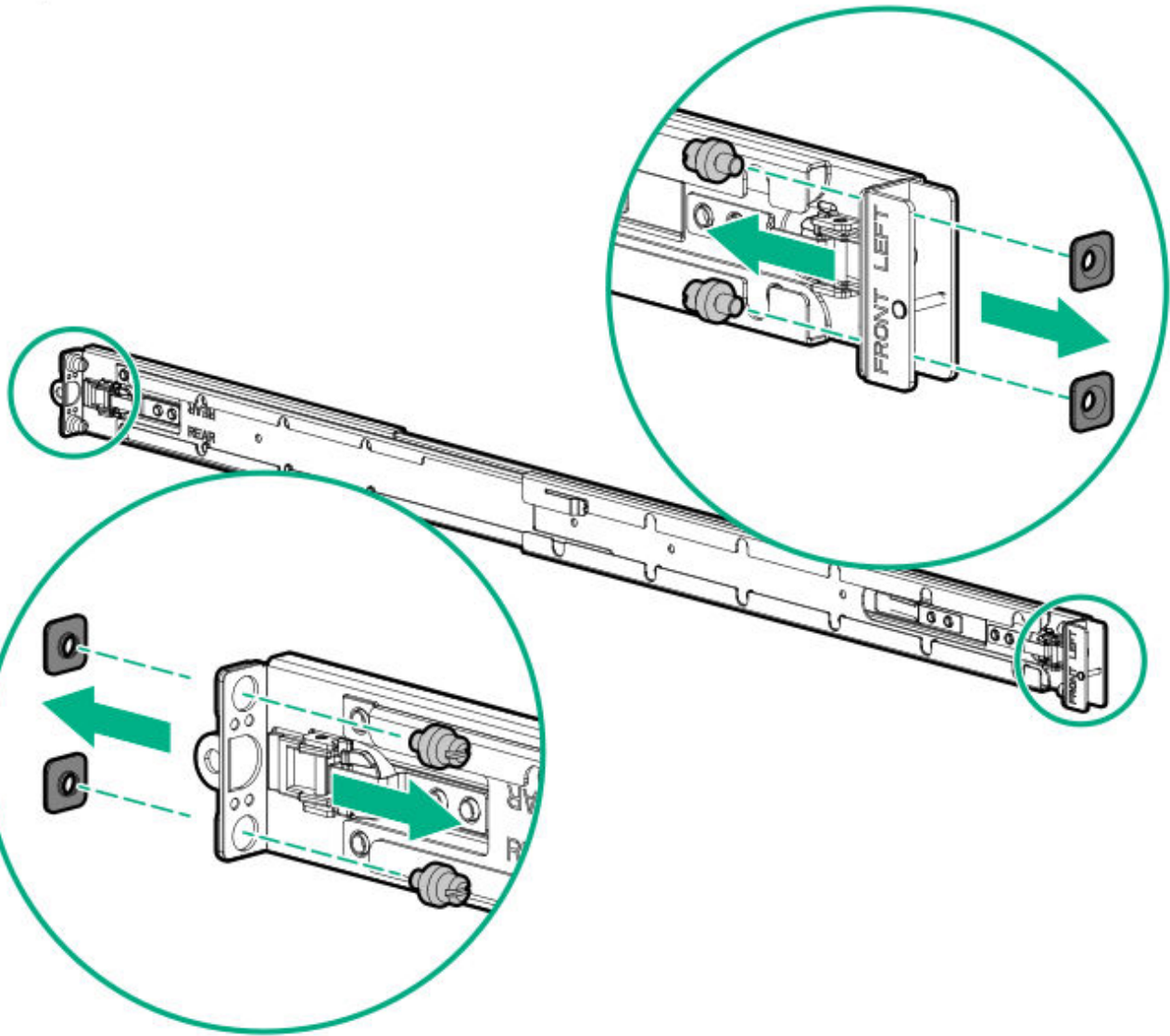

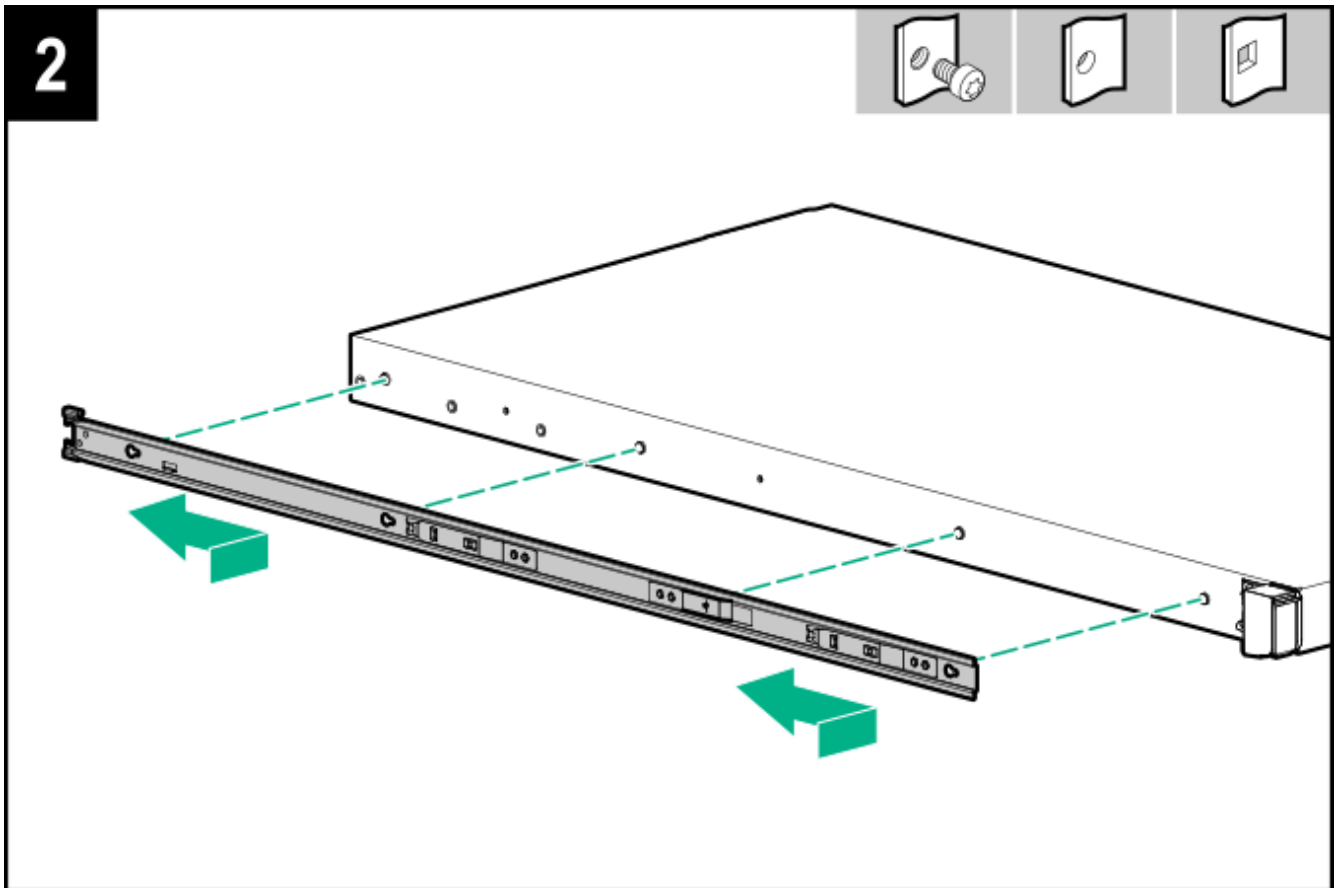
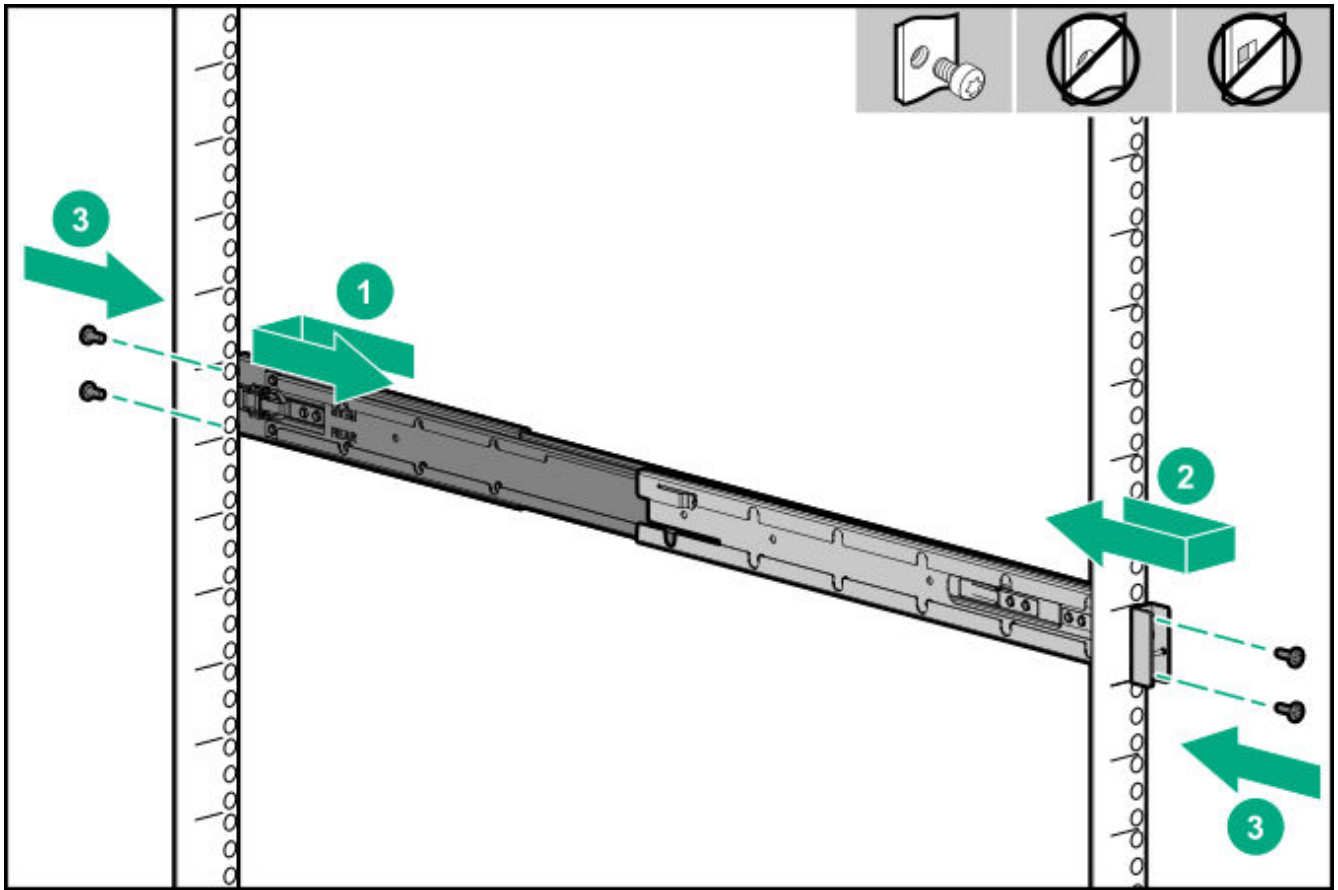

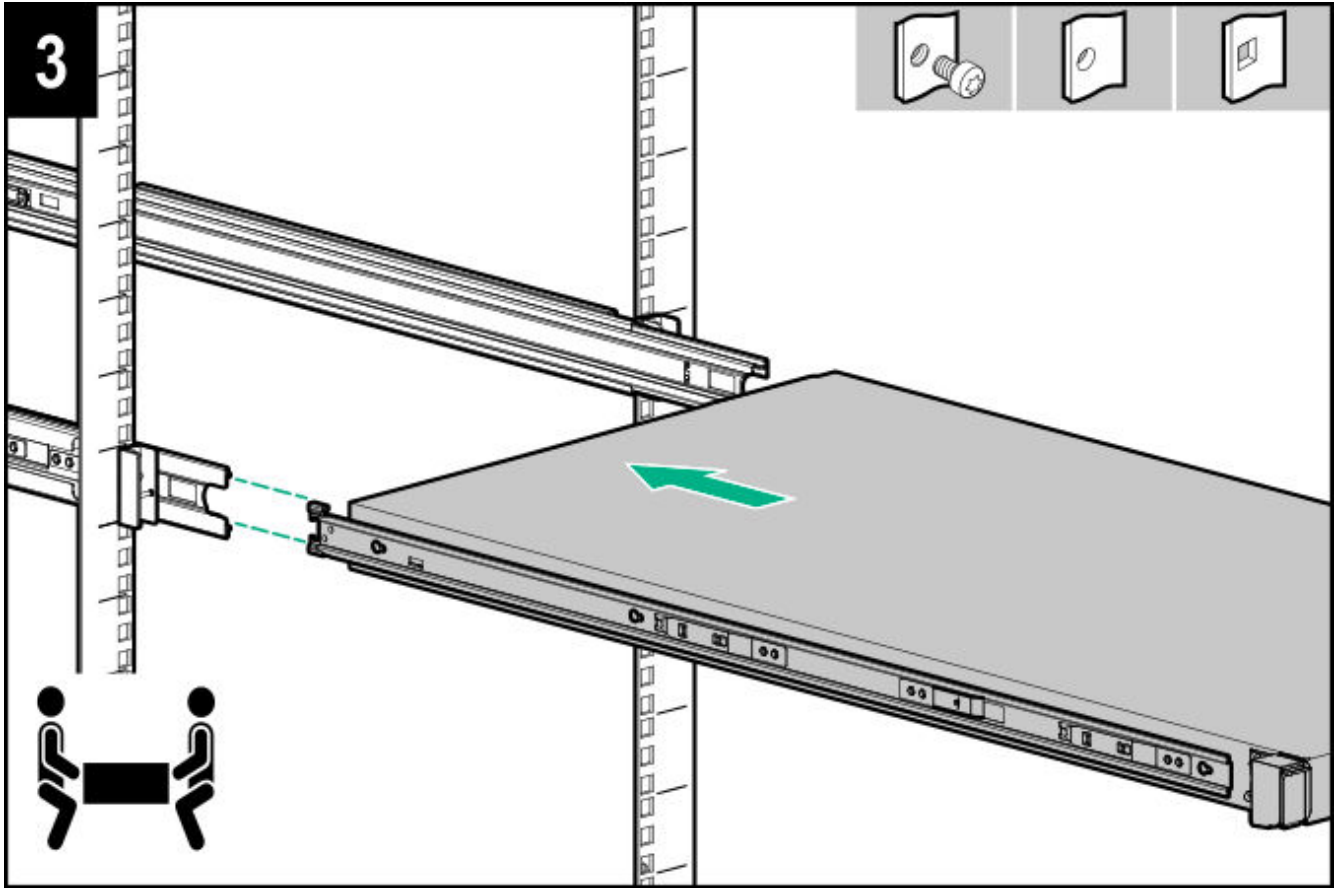

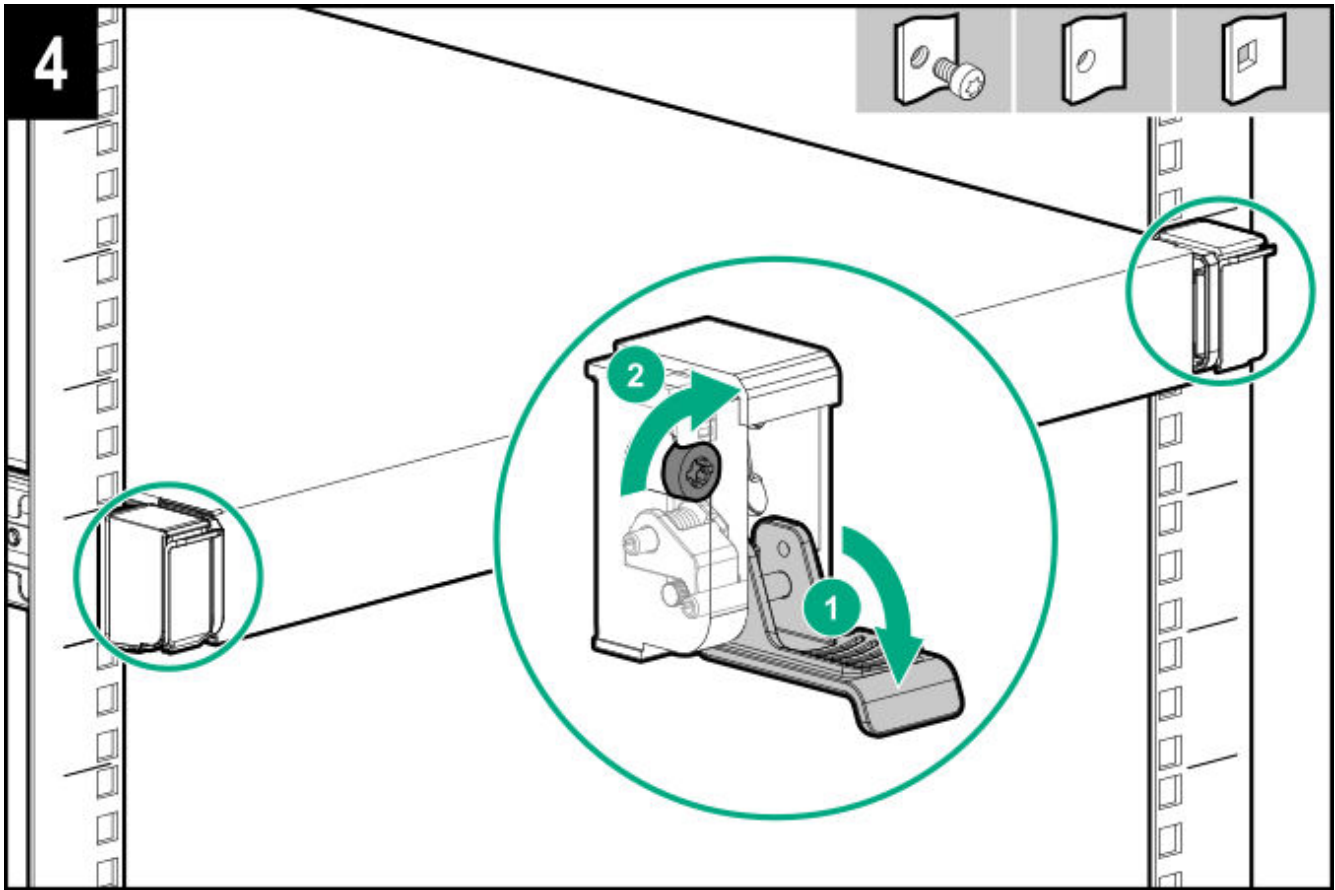

The installation of the rail kit is complete.

If the cable management arm is not installed, connect the straps included with the rail kit to each rail and then secure the cables in the strap.

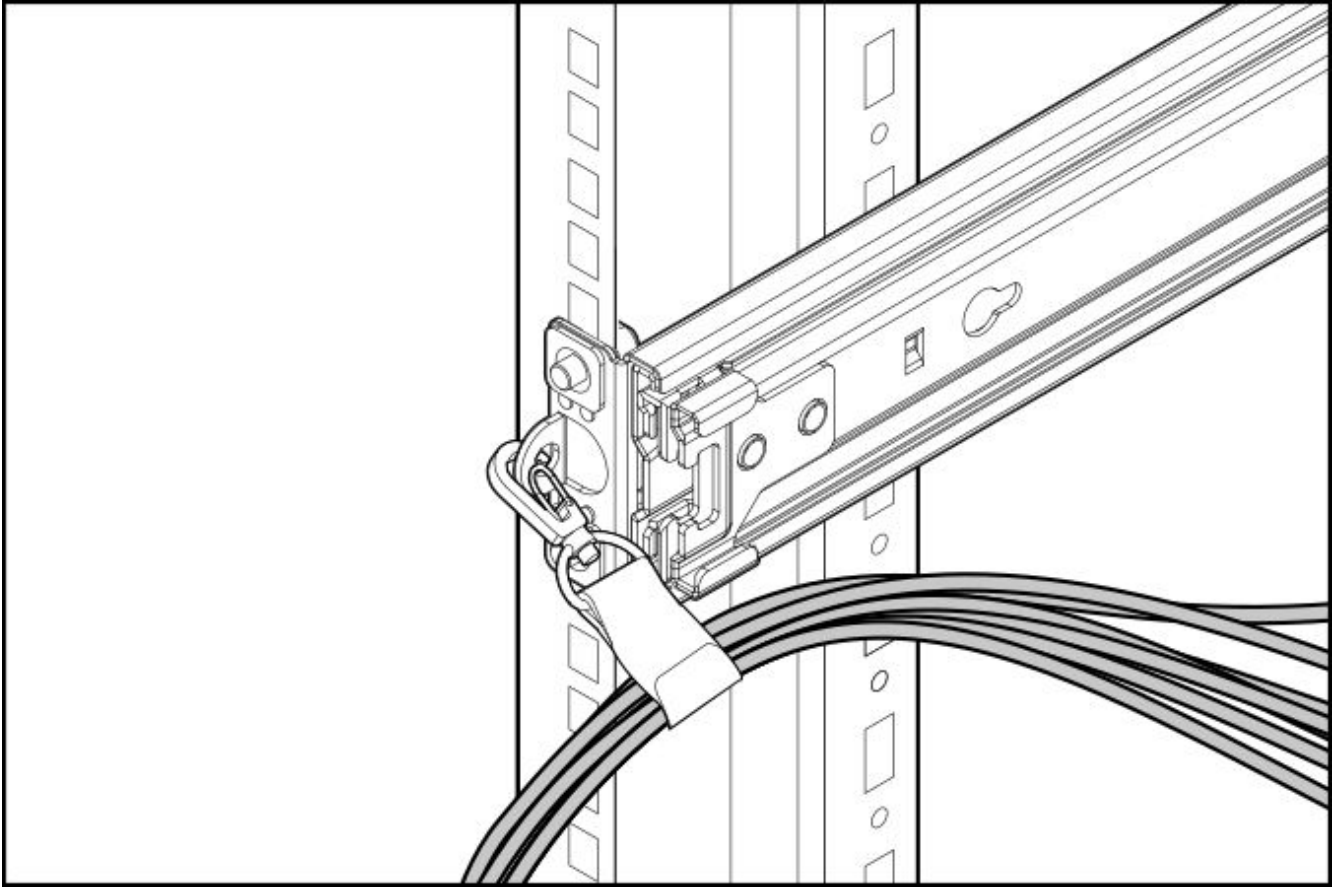

# Installing the server in a rack with the ball-bearing rail kit

## Prerequisites



**IMPORTANT:** HPE rail kits are designed to work with HPE racks. Non-HPE racks are not supported. For more information on rack rail compatibility and specifications, see the server QuickSpecs.



### **WARNING:**

To reduce the risk of personal injury or equipment damage, do one of the following:

- Use two or more people to lift and stabilize the product pieces during assembly.
- Use a lift that can handle the load of the product.



### **WARNING:**

To reduce the risk of personal injury or equipment damage, be sure that the rack is adequately stabilized before installing the enclosure .



### **CAUTION:**

Always plan the rack installation so that the heaviest item is on the bottom of the rack. Install the heaviest item first, and continue to populate the rack from the bottom to the top.

## Procedure

1. Install the rack rails.
  - For round and square-hole racks

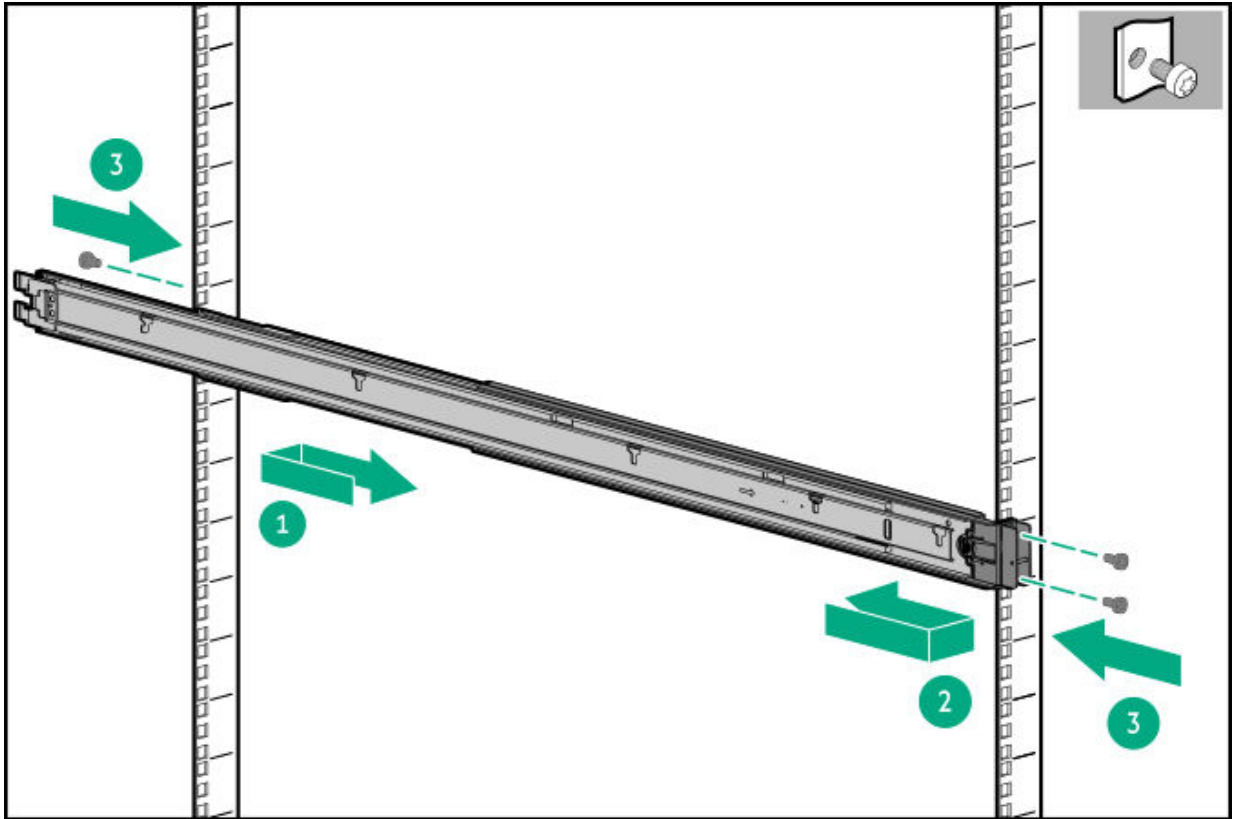

- For threaded-hole racks

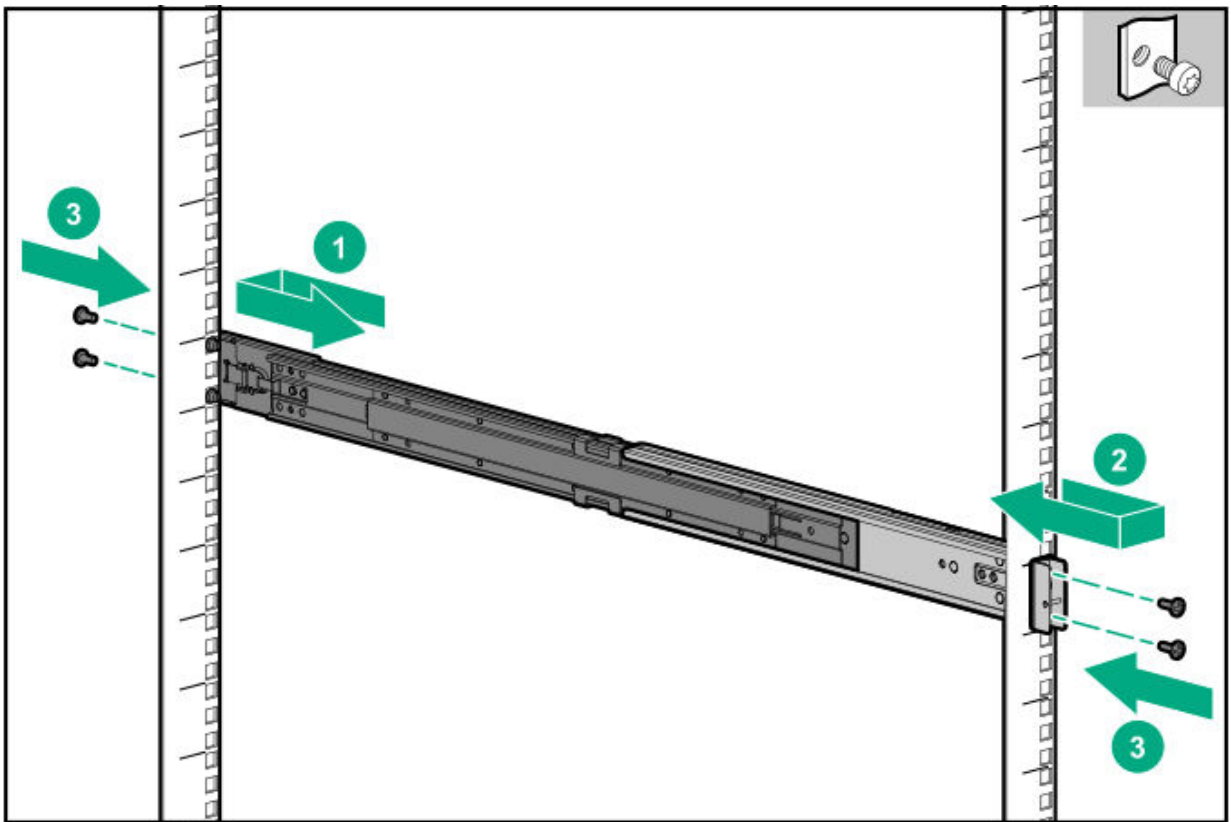
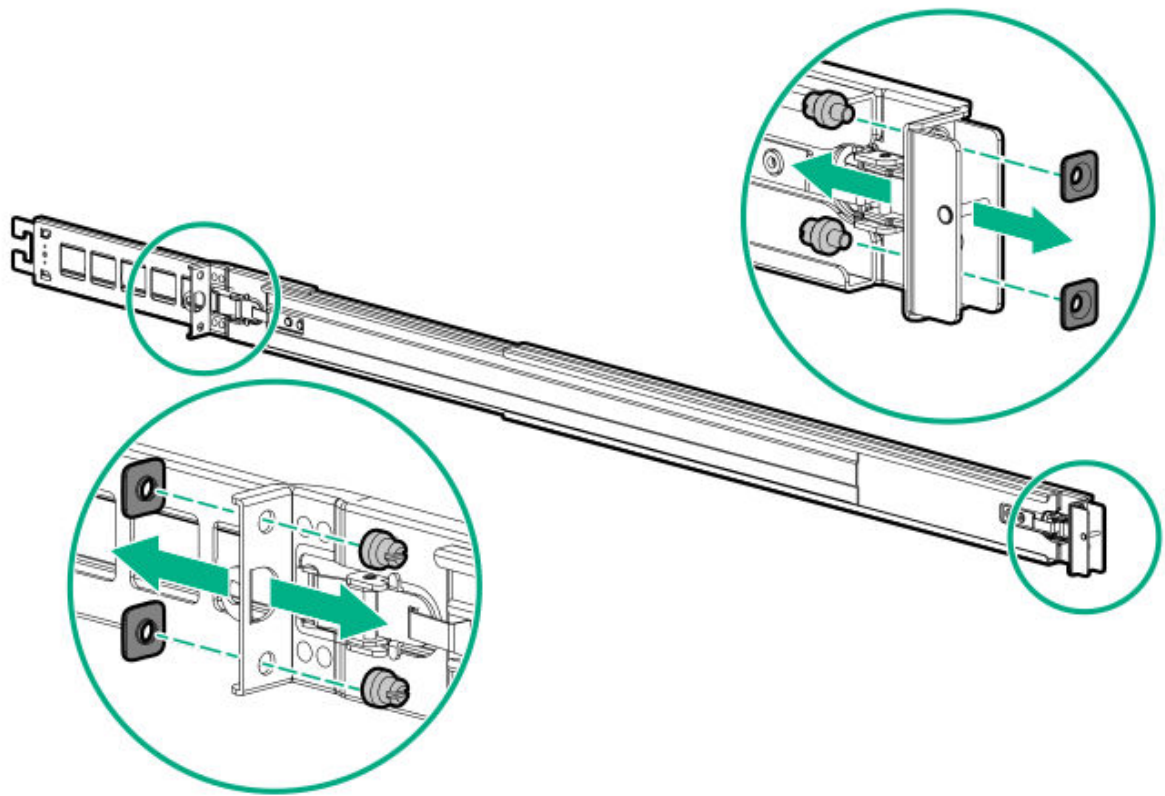

2. Fully extend the rails to the locked position.

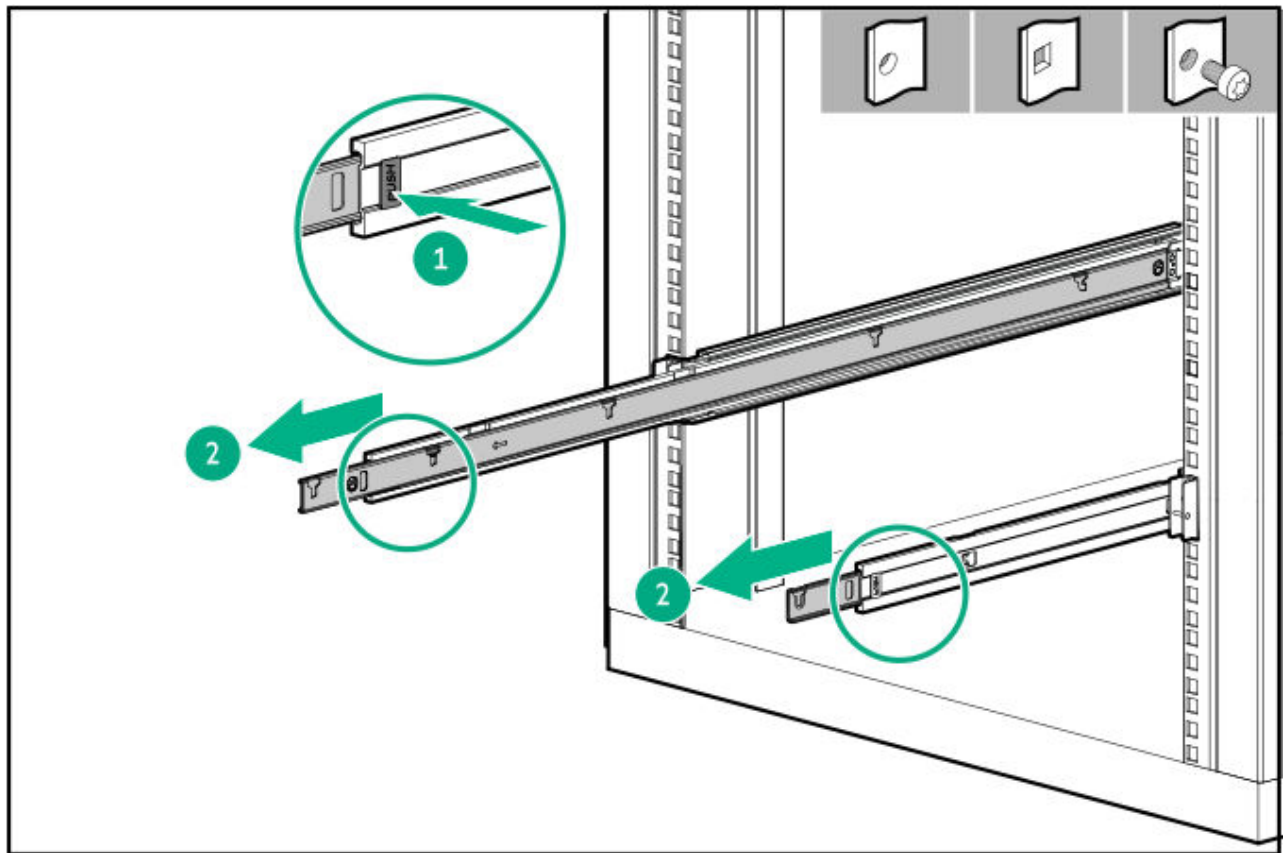

3. Verify that the rails are fully extended and the slots are aligned.

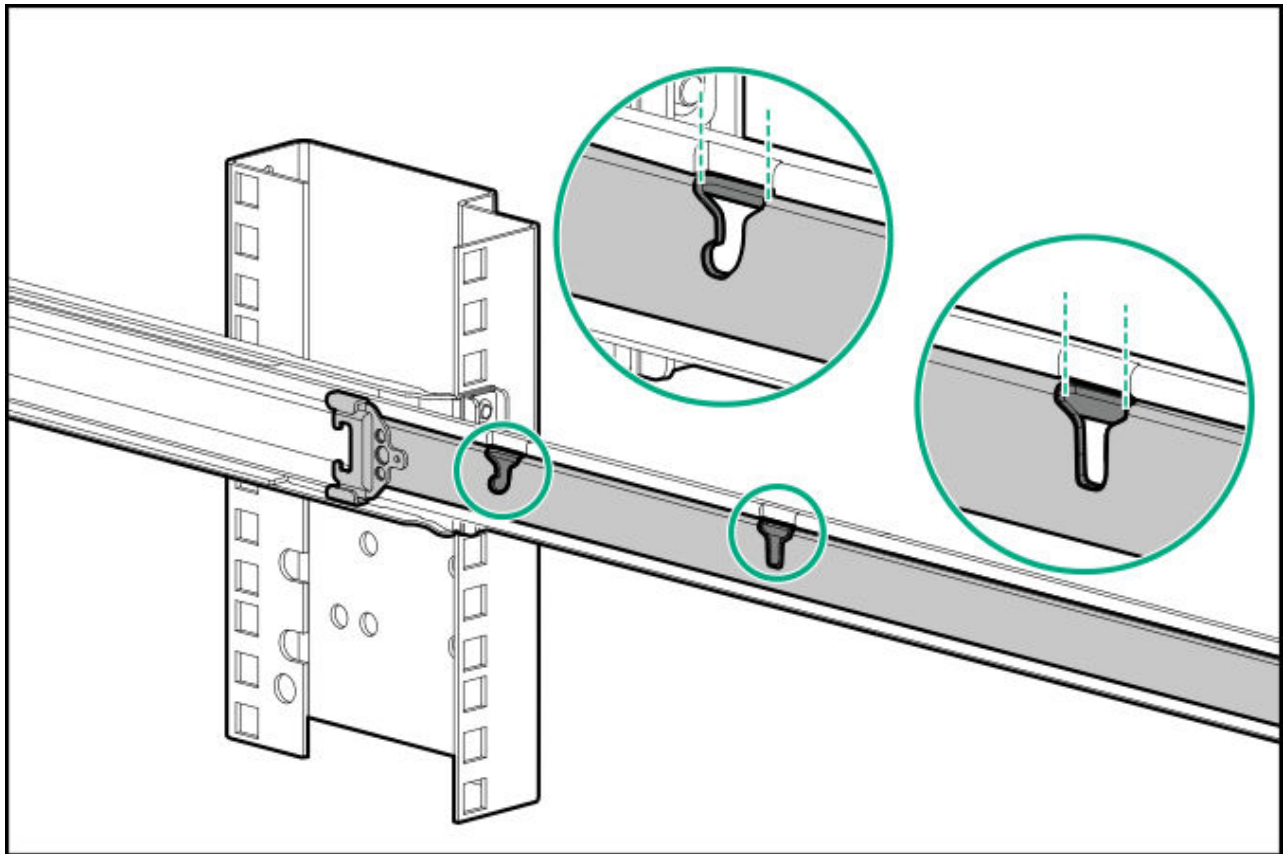

4. Install the rear of the server into the rack rails.
  - a. Install the rear of the server into the J-slots.

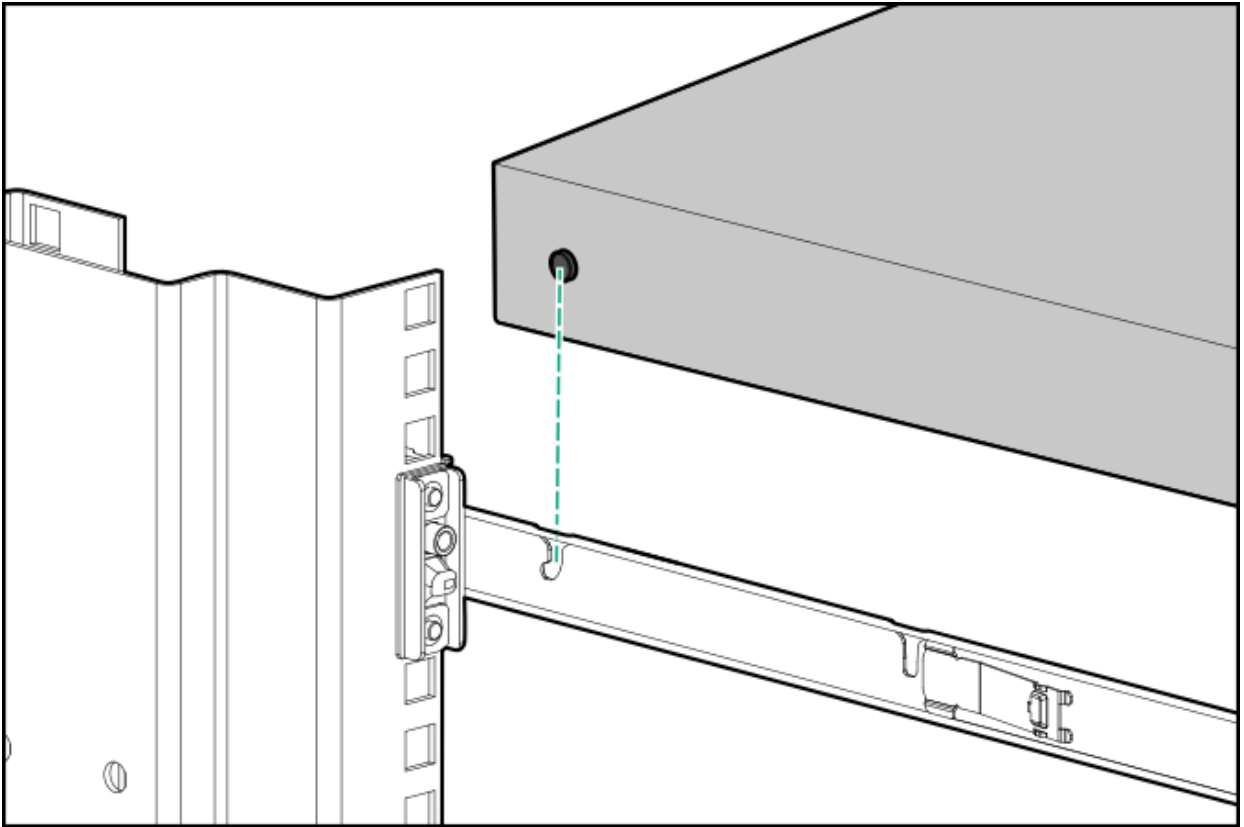

b. Install each spool to the rail.

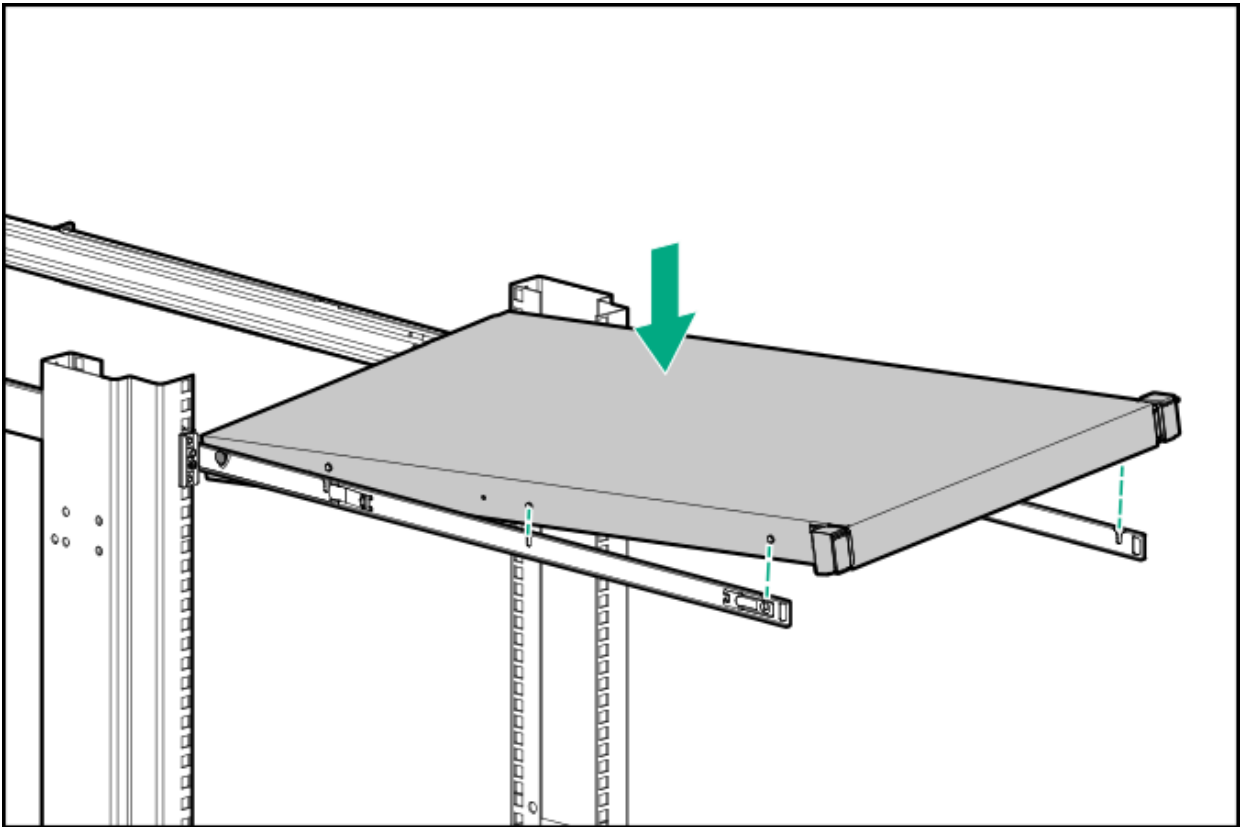

c. Install the front of the server.

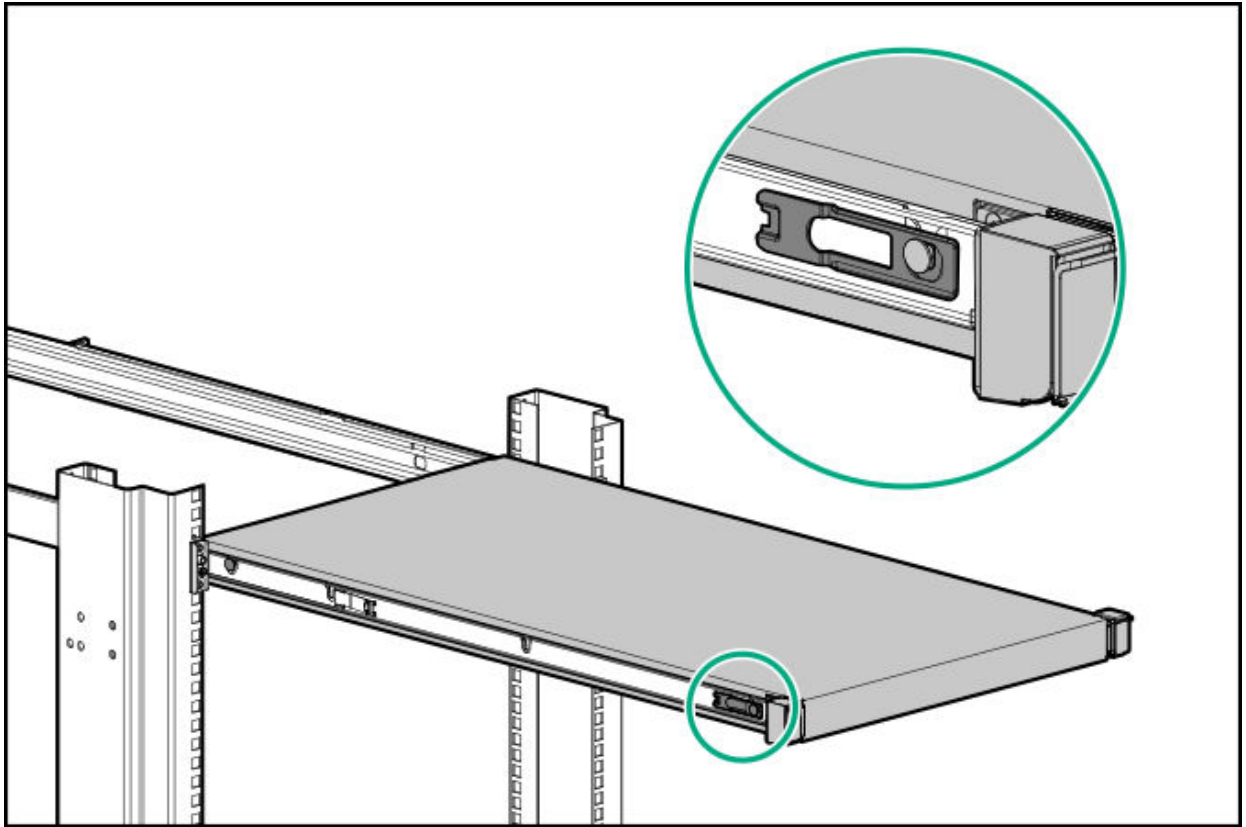

**CAUTION:**

To prevent damage to the rack rails when installing the server into the rack, make sure that all spools on the server are firmly seated on the notches on the rails.

5. Install the server into the rack.

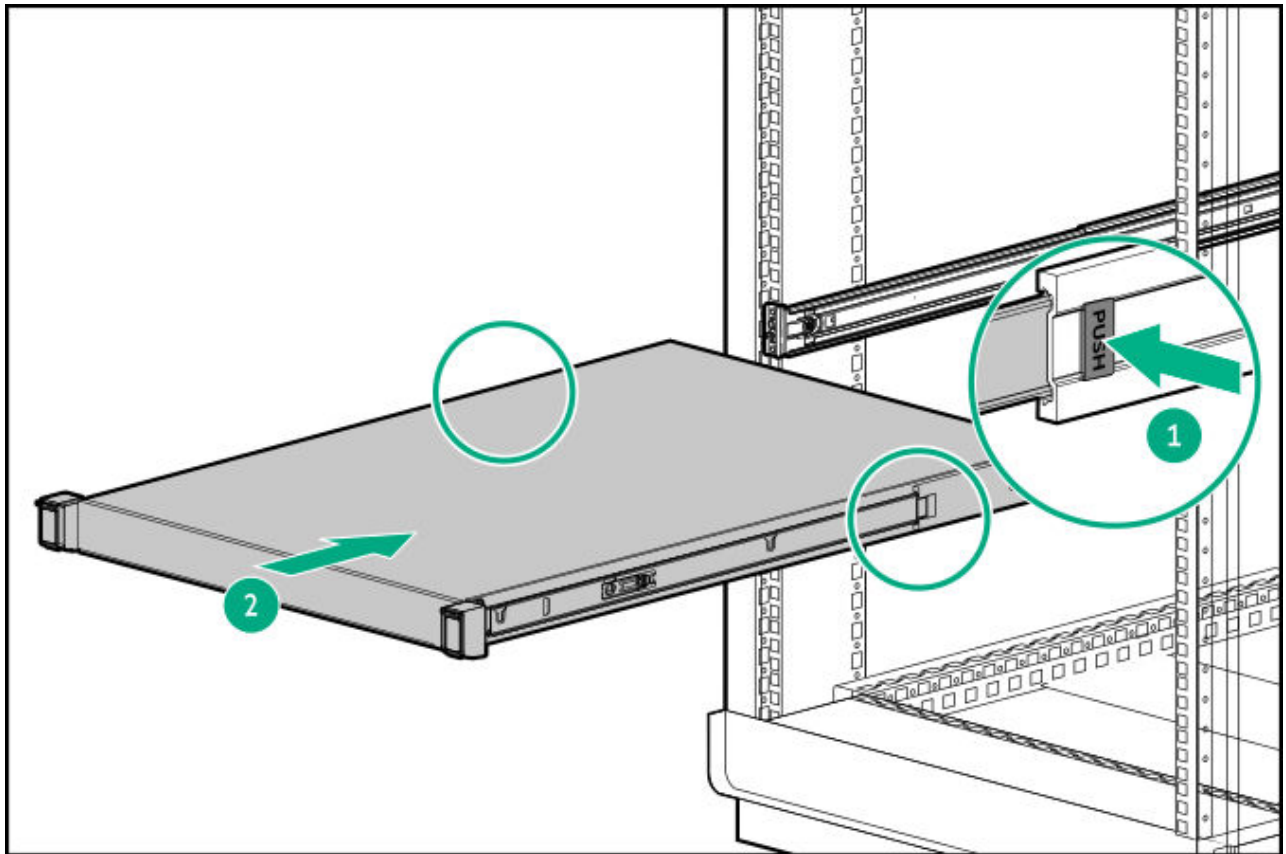

## Results

The installation is complete.

## Operating system

This ProLiant server does not ship with provisioning media. Everything required to manage and install the system software and firmware is preloaded on the server.

To operate properly, the server must have a supported operating system. Attempting to run an unsupported operating system can cause serious and unpredictable results. For the latest information on operating system support, see the [Hewlett Packard Enterprise website](#).

Failure to observe UEFI requirements for ProLiant Gen10 servers can result in errors installing the operating system, failure to recognize boot media, and other boot failures. For more information on these requirements, see the HPE UEFI Requirements on the [Hewlett Packard Enterprise website](#).

To install an operating system on the server, use one of the following methods:

- Intelligent Provisioning—For single-server deployment, updating, and provisioning capabilities. For more information, see [Installing the operating system with Intelligent Provisioning](#).

- Insight Control server provisioning—For multiserver remote OS deployment, use Insight Control server provisioning for an automated solution. For more information, see the Insight Control documentation on the [Hewlett Packard Enterprise website](#).

For additional system software and firmware updates, download the Service Pack for ProLiant from the [Hewlett Packard Enterprise website](#). Software and firmware must be updated before using the server for the first time, unless any installed software or components require an older version.

For more information, see [Keeping the system current](#).

For more information on using these installation methods, see the [Hewlett Packard Enterprise website](#).

## Subtopics

### [Installing the operating system with Intelligent Provisioning](#)

# Installing the operating system with Intelligent Provisioning

## Procedure

1. Connect the Ethernet cable between the network connector on the server and a network jack.
2. Press the Power On/Standby button.
3. During server POST, press **F10**.
4. Complete the initial Preferences and Registration portion of [Intelligent Provisioning](#).
5. At the Start screen, click **Configure and Install**.
6. To finish the installation, follow the onscreen prompts. An Internet connection is required to update the firmware and systems software.

## Selecting boot options in UEFI Boot Mode

### About this task

On servers operating in UEFI Boot Mode, the boot controller and boot order are set automatically.

## Procedure

1. Press the Power On/Standby button.
2. During the initial boot:

- To modify the server configuration ROM default settings, press the **F9** key in the ProLiant POST screen to enter the UEFI System Utilities screen. By default, the System Utilities menus are in the English language.
- If you do not need to modify the server configuration and are ready to install the system software, press the **F10** key to access Intelligent Provisioning.

## Results

For more information on automatic configuration, see the UEFI documentation on the [Hewlett Packard Enterprise website](#).

# Selecting boot options

## About this task

This server supports both Legacy BIOS Boot Mode and UEFI Boot Mode. On servers operating in UEFI Boot Mode, the boot controller and boot order are set automatically.

## Procedure

1. Press the Power On/Standby button.
2. Do one of the following:
  - To enter the UEFI System Utilities screen and modify the server configuration ROM default settings, press the **F9** key on the ProLiant POST screen. Choose one of the following boot modes:
    - Legacy BIOS
    - UEFI (default)
  - If you do not need to modify the server configuration and are ready to install the system software, press the **F10** key to access Intelligent Provisioning.

## Results

For more information on automatic configuration, see the UEFI documentation on the [Hewlett Packard Enterprise website](#).

# Hardware options installation

## Subtopics

### **Hewlett Packard Enterprise product QuickSpecs**

#### **Introduction**

#### **Installing the cable management arm**

#### **Installing a redundant hot-plug power supply**

#### **Memory options**

#### **Installing a high-performance fan**

#### **Drive options**

#### **Universal media bay options**

#### **Installing the 4 LFF optical drive option**

#### **Installing the rear drive riser cage option**

#### **Primary PCI riser cage options**

#### **Secondary PCI riser options**

#### **Controller options**

#### **Processor and heatsink options**

#### **Installing the Systems Insight Display power module**

#### **Installing the 4 LFF display port/USB module**

#### **Installing the serial cable option**

#### **Installing the Chassis Intrusion Detection switch option**

#### **Installing the FlexibleLOM option**

#### **Installing the Pensando DSP DSC-25 2p SFP28 card with the iLO Sideband ALOM Module**

#### **Installing the HPE NS204i-p Gen10 Plus Boot Device option**

#### **Energy pack options**

#### **HPE Trusted Platform Module 2.0 Gen10 option**

## Hewlett Packard Enterprise product QuickSpecs

For more information about product features, specifications, options, configurations, and compatibility, see the product QuickSpecs on the Hewlett Packard Enterprise website (<https://www.hpe.com/info/qs>).

## Introduction

Install any hardware options before initializing the server. If multiple options are being installed, read the installation instructions for all the hardware options to identify similar steps and streamline the installation process.



**WARNING:** To reduce the risk of personal injury from hot surfaces, allow the drives and the internal system components to cool before touching them.



**CAUTION:** To prevent damage to electrical components, properly ground the server before beginning any installation procedure. Improper grounding can cause electrostatic discharge.

## Installing the cable management arm

### About this task

The management arm can be installed to swing out from the left or right side.

### Procedure

1. Install the inner and outer brackets to the inner and outer rails.

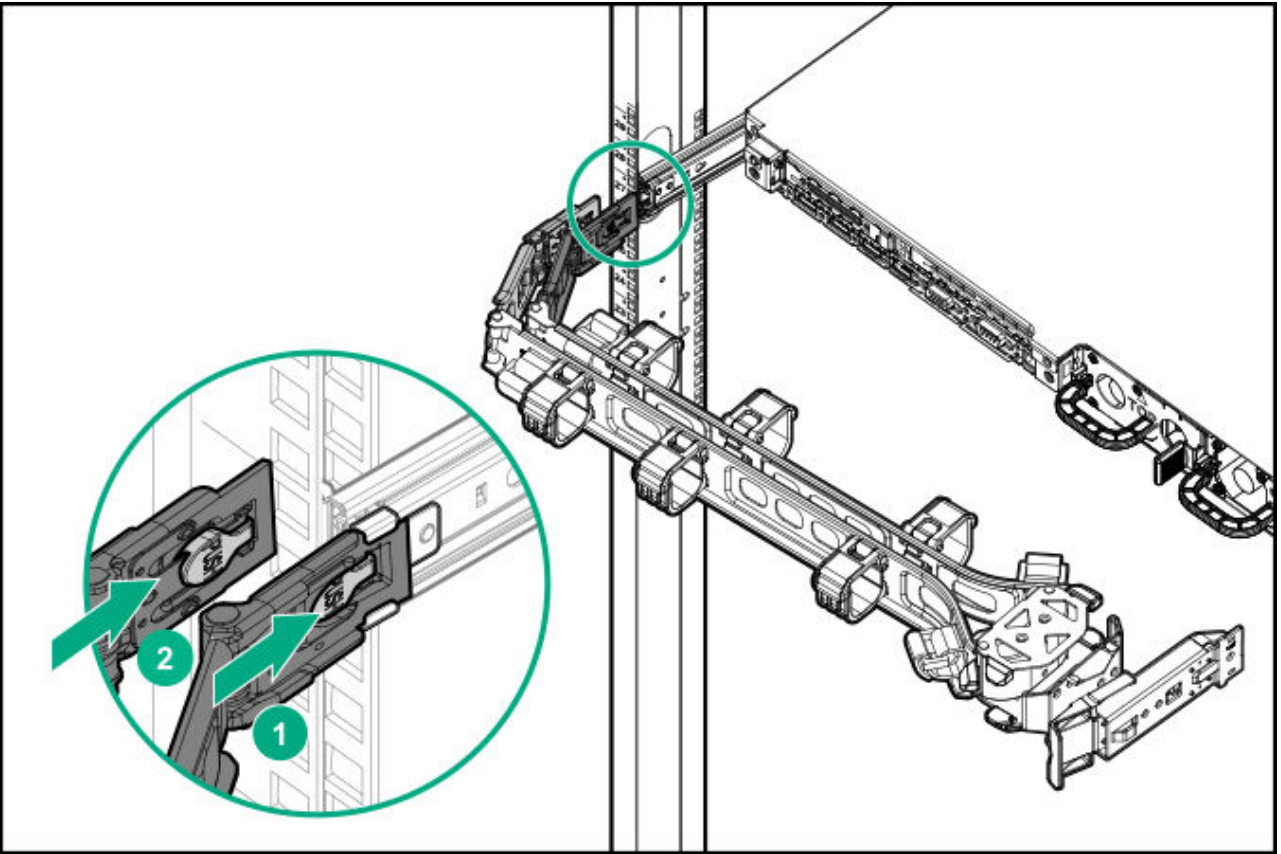

2. Install the elbow latch.

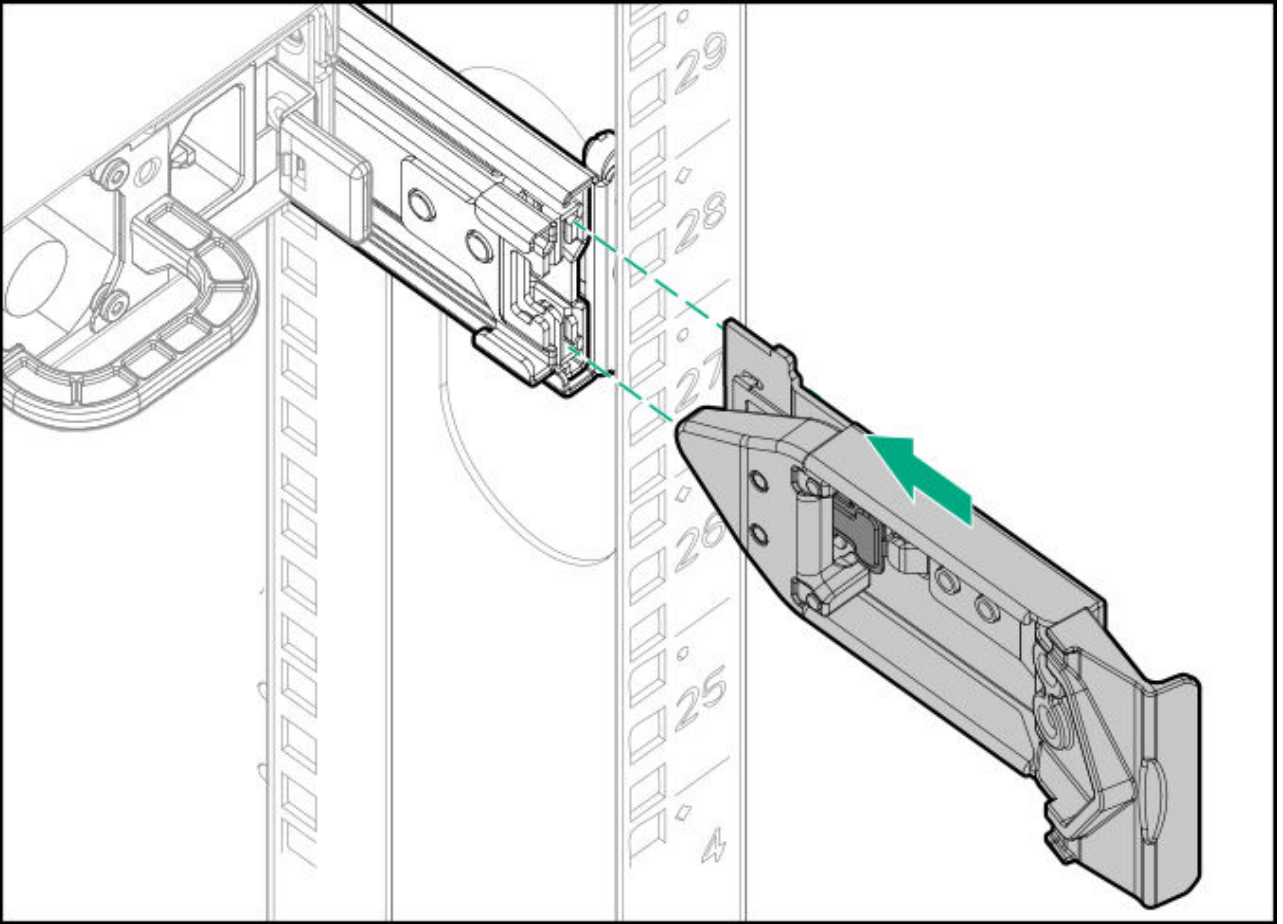

3. Install and route cables through the baskets.

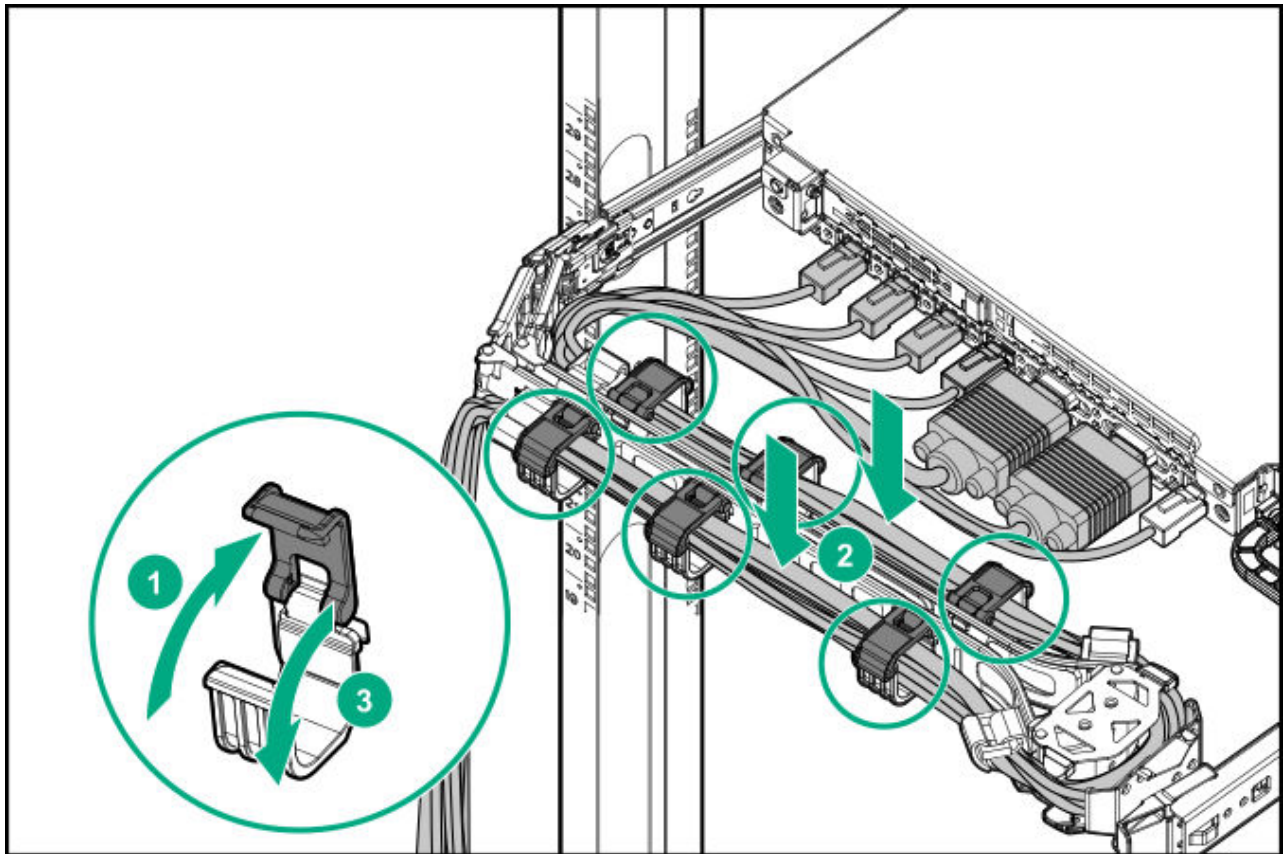

## Installing a redundant hot-plug power supply

### Prerequisites

Before installing this option, be sure you have the following:

The components included with the hardware option kit

## Procedure

1. Observe the following alerts:



**CAUTION:** All power supplies installed in the server must have the same output power capacity. Verify that all power supplies have the same part number and label color. The system becomes unstable and may shut down when it detects mismatched power supplies.



**CAUTION:** To prevent improper cooling and thermal damage, do not operate the server unless all bays are populated with either a component or a blank.

2. Access the product rear panel (Release the cable management arm).
3. Remove the blank.



**WARNING:** To reduce the risk of personal injury from hot surfaces, allow the power supply, power supply blank, or dual slot power supply adapter to cool before touching it.

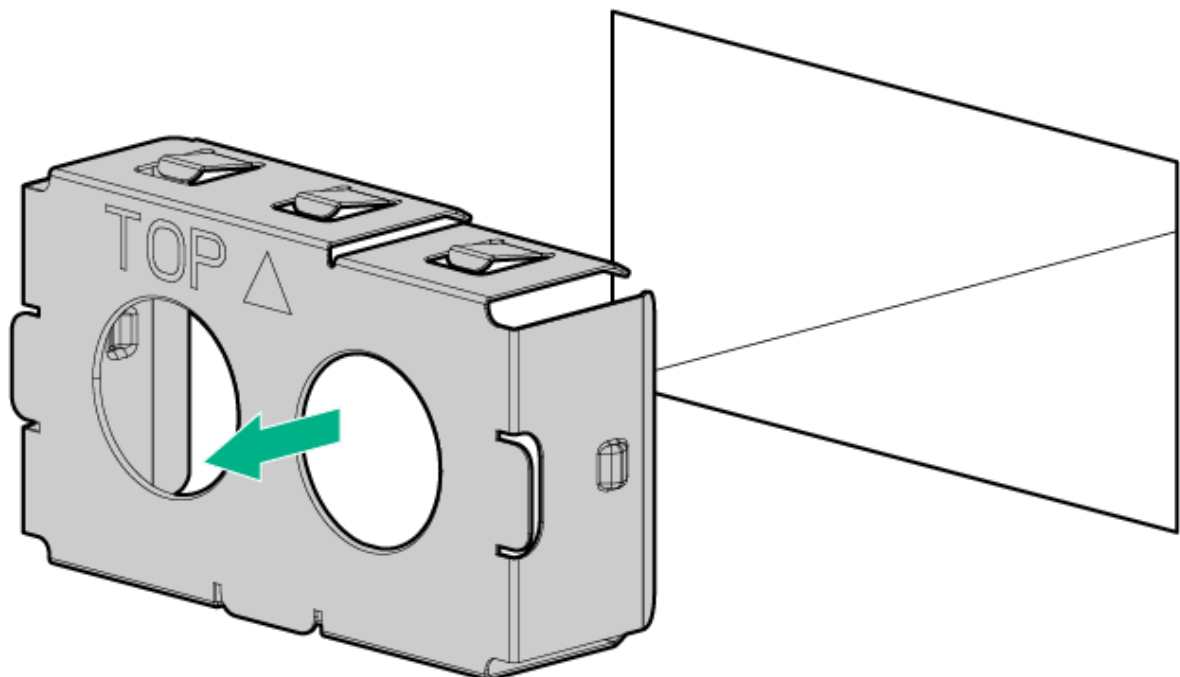

4. Insert the power supply into the power supply bay until it clicks into place.

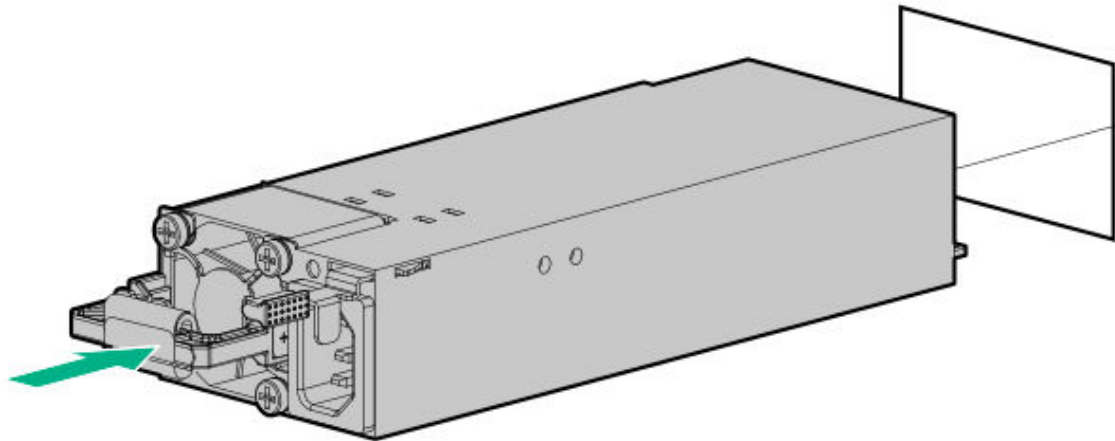

5. Connect the power cord to the power supply.
6. Route the power cord. Use best practices when routing power cords and other cables. A cable management arm is available to help with routing. To obtain a cable management arm, contact a Hewlett Packard Enterprise authorized reseller.
7. Connect the power cord to the AC power source.
8. Be sure that the power supply LED is green ([Rear panel LEDs](#)).

## Memory options



**IMPORTANT:** This server does not support mixing LRDIMMs and RDIMMs. Attempting to mix any combination of these DIMMs can cause the server to halt during BIOS initialization. All memory installed in the server must be of the same type.

### Subtopics

[\*\*DIMM and NVDIMM population information\*\*](#)

[\*\*DIMM-processor compatibility\*\*](#)

[\*\*HPE SmartMemory speed information\*\*](#)

[\*\*Installing a DIMM\*\*](#)

[\*\*HPE 16GB NVDIMM option\*\*](#)

[\*\*Intel Optane persistent memory 100 series for HPE\*\*](#)

## DIMM and NVDIMM population information

For specific DIMM and NVDIMM population information, see the DIMM population guidelines on the Hewlett Packard Enterprise website (<https://www.hpe.com/docs/memory-population-rules>).

### DIMM-processor compatibility

The installed processor determines the type of DIMM that is supported in the server:

- First-generation Intel Xeon Scalable processors support DDR4-2666 DIMMs.
- Second-generation Intel Xeon Scalable processors support DDR4-2933 DIMMs.

Mixing DIMM types is not supported. Install only the supported DDR4-2666 or DDR4-2933 DIMMs in the server.

### HPE SmartMemory speed information

For more information about memory speed information, see the Hewlett Packard Enterprise website (<https://www.hpe.com/docs/memory-speed-table>).

## Installing a DIMM

### Prerequisites

Before installing this option, be sure you have the following:

The components included with the hardware option kit

For more information on specific options, see the server QuickSpecs on the [Hewlett Packard Enterprise website](#).

### About this task

The server supports up to 24 DIMMs.

### Procedure

1. Power down the server ([Power down the server](#)).

2. Remove all power:
  - a. Disconnect each power cord from the power source.
  - b. Disconnect each power cord from the server.
3. Do one of the following:
  - a. Extend the server from the rack (Extend the server from the rack).
  - b. Remove the server from the rack (Remove the server from the rack).
4. Remove the access panel (Remove the access panel).
5. Open the DIMM slot latches.
6. Install the DIMM.

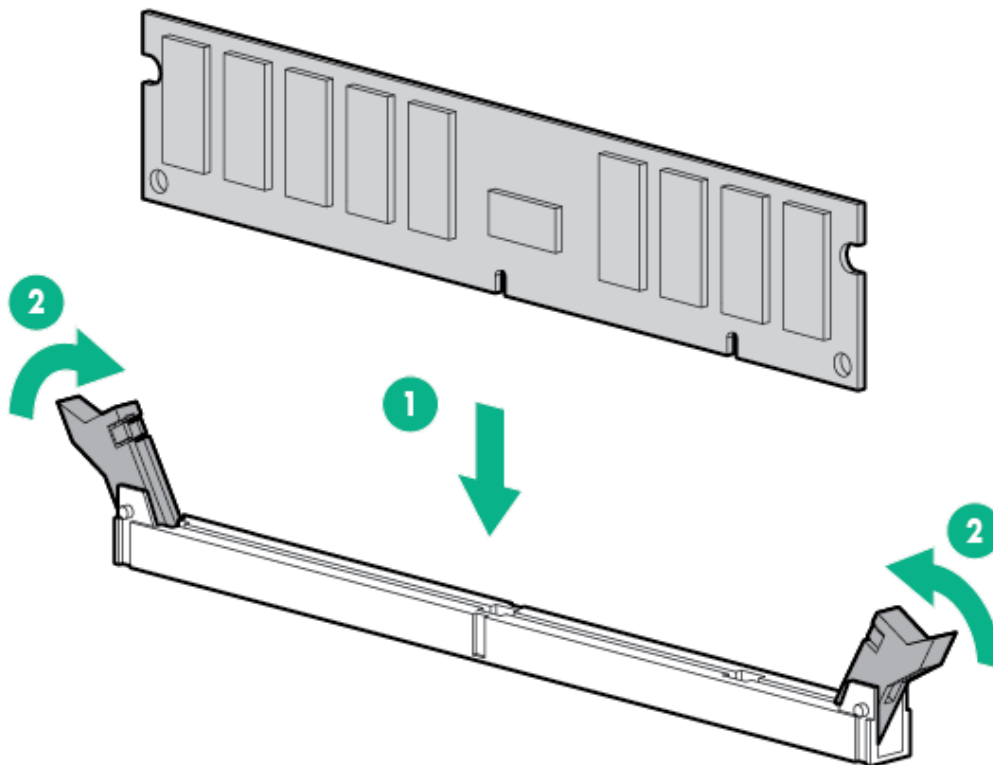

7. Install the access panel (Install the access panel).
8. Install the server in the rack.
9. Connect each power cord to the server.
10. Connect each power cord to the power source.

.1. Power up the server (Power up the server).

## Results

Use the BIOS/Platform Configuration (RBSU) in the UEFI System Utilities to configure the memory mode.

For more information about LEDs and troubleshooting failed DIMMs, see Systems Insight Display combined LED descriptions.

## HPE 16GB NVDIMM option

HPE NVDIMMs are flash-backed NVDIMMs used as fast storage and are designed to eliminate smaller storage bottlenecks. The HPE 16GB NVDIMM for HPE ProLiant Gen10 servers is ideal for smaller database storage bottlenecks, write caching tiers, and any workload constrained by storage bottlenecks.

The HPE 16GB NVDIMM is supported on select HPE ProLiant Gen10 servers with first generation Intel Xeon Scalable processors. The server can support up to 12 NVDIMMs in 2 socket servers (up to 192GB) and up to 24 NVDIMMs in 4 socket servers (up to 384GB). The HPE Smart Storage Battery provides backup power to the memory slots allowing data to be moved from the DRAM portion of the NVDIMM to the Flash portion for persistence during a power down event.

For more information on HPE NVDIMMs, see the Hewlett Packard Enterprise website (<https://www.hpe.com/info/persistentmemory>).

### Subtopics

[NVDIMM-processor compatibility](#)

[Server requirements for NVDIMM support](#)

[Installing an NVDIMM](#)

[Configuring the server for NVDIMMs](#)

[NVDIMM sanitization](#)

[NVDIMM relocation guidelines](#)

## NVDIMM-processor compatibility

HPE 16GB NVDIMMs are only supported in servers with first-generation Intel Xeon Scalable processors installed.

## Server requirements for NVDIMM support

Before installing an HPE 16GB NVDIMM in a server, make sure that the following components and software are available:

- A supported HPE server using Intel Xeon Scalable Processors: For more information, see the NVDIMM QuickSpecs on the Hewlett Packard Enterprise website (<https://www.hpe.com/info/qs>).
- An HPE Smart Storage Battery
- A minimum of one regular DIMM: The system cannot have only NVDIMM-Ns installed.
- A supported operating system with persistent memory/NVDIMM drivers. For the latest software information, see the Hewlett Packard Enterprise website (<https://persistentmemory.hpe.com>).
- For minimum firmware versions, see the HPE 16GB NVDIMM User Guide on the Hewlett Packard Enterprise website (<https://www.hpe.com/info/nvdimm-docs>).

To determine NVDIMM support for your server, see the server QuickSpecs on the Hewlett Packard Enterprise website (<https://www.hpe.com/info/qs>).

## Installing an NVDIMM

### Prerequisites

Before installing an NVDIMM, be sure the server meets the [Server requirements for NVDIMM support](#).

## About this task



### CAUTION:

To avoid damage to the hard drives, memory, and other system components, the air baffle, drive blanks, and access panel must be installed when the server is powered up.



### CAUTION:

To avoid damage to the hard drives, memory, and other system components, be sure to install the correct DIMM baffles for your server model.



### CAUTION:

DIMMs are keyed for proper alignment. Align notches in the DIMM with the corresponding notches in the DIMM slot before inserting the DIMM. Do not force the DIMM into the slot. When installed properly, not all DIMMs will face in the same direction.



### CAUTION:

Electrostatic discharge can damage electronic components. Be sure you are properly grounded before beginning this procedure.



### CAUTION:

Failure to properly handle DIMMs can damage the DIMM components and the system board connector. For more information, see the DIMM handling guidelines in the troubleshooting guide for your product on the Hewlett Packard Enterprise website:

- HPE ProLiant Gen10 (<https://www.hpe.com/info/gen10-troubleshooting>)
- HPE Synergy (<https://www.hpe.com/info/synergy-troubleshooting>)



### CAUTION:

Unlike traditional storage devices, NVDIMMs are fully integrated in with the ProLiant server. Data loss can occur when system components, such as the processor or HPE Smart Storage Battery, fails. HPE Smart Storage battery is a critical component required to perform the backup functionality of NVDIMMs. It is important to act when HPE Smart Storage Battery related failures occur. Always follow best practices for ensuring data protection.

## Procedure

1. Power down the server ([Power down the server](#)).
2. Remove all power:
  - a. Disconnect each power cord from the power source.
  - b. Disconnect each power cord from the server.
3. Do one of the following:
  - a. Extend the server from the rack ([Extend the server from the rack](#)).
  - b. Remove the server from the rack ([Remove the server from the rack](#)).
4. Remove the access panel ([Remove the access panel](#)).
5. Locate any NVDIMMs already installed in the server.
6. Verify that all LEDs on any installed NVDIMMs are off.
7. Install the NVDIMM.

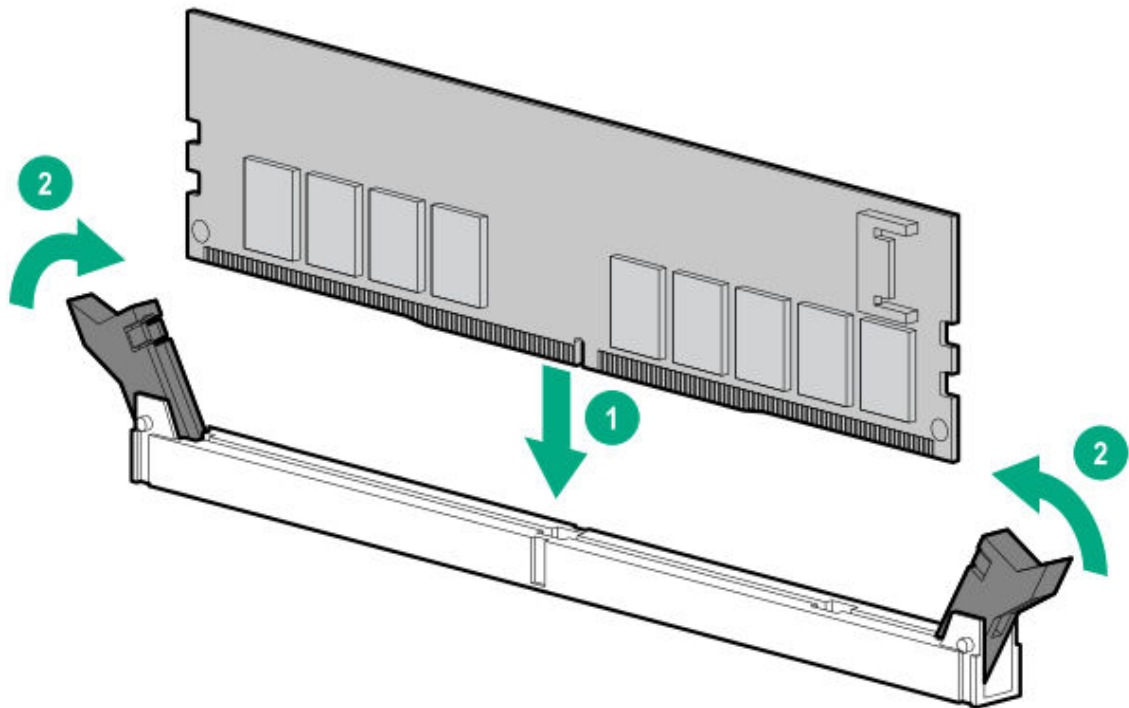

8. Install and connect the HPE Smart Storage Battery, if it is not already installed.
  - [Installing an energy pack in 8 SFF and 4 LFF configurations](#)
  - [Installing an energy pack in the 10 SFF SAS/SATA/NVMe Combo backplane configuration](#)

9. Install any components removed to access the DIMM slots and the HPE Smart Storage Battery.
- .0. Install the access panel.
- .1. Slide or install the server into the rack.
- .2. If removed, reconnect all power cables.
- .3. Power up the server.
- .4. If required, sanitize the NVDIMM-Ns. For more information, see [NVDIMM sanitization](#).

## Configuring the server for NVDIMMs

After installing NVDIMMs, configure the server for NVDIMMs. For information on configuring settings for NVDIMMs, see the HPE 16GB NVDIMM User Guide on the Hewlett Packard Enterprise website (<https://www.hpe.com/info/nvdimm-docs>).

The server can be configured for NVDIMMs using either of the following:

- UEFI System Utilities—Use System Utilities through the Remote Console to configure the server for NVDIMM memory options by pressing the **F9** key during POST. For more information about UEFI System Utilities, see the Hewlett Packard Enterprise website (<https://www.hpe.com/info/uefi/docs>).
- iLO RESTful API for HPE iLO 5—For more information about configuring the system for NVDIMMs, see <https://hewlettpackard.github.io/ilo-rest-api-docs/ilo5/>.

## NVDIMM sanitization

Media sanitization is defined by NIST SP800-88 Guidelines for Media Sanitization (Rev 1, Dec 2014) as "a general term referring to the actions taken to render data written on media unrecoverable by both ordinary and extraordinary means."

The specification defines the following levels:

- Clear: Overwrite user-addressable storage space using standard write commands; might not sanitize data in areas not currently user-addressable (such as bad blocks and overprovisioned areas)
- Purge: Overwrite or erase all storage space that might have been used to store data using dedicated device sanitize commands, such that data retrieval is "infeasible using state-of-the-art laboratory techniques"

- Destroy: Ensure that data retrieval is "infeasible using state-of-the-art laboratory techniques" and render the media unable to store data (such as disintegrate, pulverize, melt, incinerate, or shred)

The NVDIMM-N Sanitize options are intended to meet the Purge level.

For more information on sanitization for NVDIMMs, see the following sections in the HPE 16GB NVDIMM User Guide on the Hewlett Packard Enterprise website (<https://www.hpe.com/info/nvdimm-docs>):

- NVDIMM sanitization policies
- NVDIMM sanitization guidelines
- Setting the NVDIMM-N Sanitize/Erase on the Next Reboot Policy

NIST SP800-88 Guidelines for Media Sanitization (Rev 1, Dec 2014) is available for download from the NIST website (<https://nvlpubs.nist.gov/nistpubs/SpecialPublications/NIST.SP.800-88r1.pdf>).

## NVDIMM relocation guidelines

### Requirements for relocating NVDIMMs or a set of NVDIMMs when the data must be preserved

- The destination server hardware must match the original server hardware configuration.
- All System Utilities settings in the destination server must match the original System Utilities settings in the original server.
- If NVDIMM-Ns are used with NVDIMM Interleaving ON mode in the original server, do the following:
  - Install the NVDIMMs in the same DIMM slots in the destination server.
  - Install the entire NVDIMM set (all the NVDIMM-Ns on the processor) on the destination server.

This guideline would apply when replacing a system board due to system failure.

If any of the requirements cannot be met during NVDIMM relocation, do the following:

- Manually back up the NVDIMM-N data before relocating NVDIMM-Ns to another server.
- Relocate the NVDIMM-Ns to another server.
- Sanitize all NVDIMM-Ns on the new server before using them.

### Requirements for relocating NVDIMMs or a set of NVDIMMs when the data does not have to be preserved

If data on the NVDIMM-N or set of NVDIMM-Ns does not have to be preserved, then

- Move the NVDIMM-Ns to the new location and sanitize all NVDIMM-Ns after installing them to the new location. For more information, see [NVDIMM sanitization](#).

- Observe all DIMM and NVDIMM population guidelines. For more information, see [DIMM and NVDIMM population information](#).
- Observe the process for removing an NVDIMM.
- Observe the process for installing an NVDIMM.
- Review and configure the system settings for NVDIMMs. For more information, see [Configuring the server for NVDIMMs](#).

## Intel Optane persistent memory 100 series for HPE

Intel Optane persistent memory 100 series for HPE offers the flexibility to deploy as dense memory (Memory mode) or fast storage (App Direct mode) and enables per-socket memory capacity of up to 3.0 TB. Persistent memory modules, together with traditional volatile DRAM DIMMs, provide fast, high-capacity, cost-effective memory and storage to transform big data workloads and analytics by enabling data to be stored, moved, and processed quickly.

Persistent memory modules use the standard DIMM form factor and are installed alongside DIMMs in a server memory slot. Intel Optane persistent memory 100 series for HPE is designed for use only with second-generation Intel Xeon Scalable processors, and is available in the following capacities:

- 128 GB
- 256 GB
- 512 GB

### Subtopics

[\*\*Persistent memory module-processor compatibility\*\*](#)

[\*\*Persistent memory module population information\*\*](#)

[\*\*System requirements for persistent memory module support\*\*](#)

[\*\*Installing persistent memory modules\*\*](#)

[\*\*Configuring the server for Intel Optane persistent memory 100 series for HPE\*\*](#)

## Persistent memory module-processor compatibility

Intel Optane persistent memory 100 series for HPE is supported only in servers with second-generation Intel Xeon Scalable processors installed.

# Persistent memory module population information

For specific population and configuration information, see the memory population guidelines on the Hewlett Packard Enterprise website (<https://www.hpe.com/docs/memory-population-rules>).

## System requirements for persistent memory module support



### IMPORTANT:

Hewlett Packard Enterprise recommends that you implement best-practice configurations such as clustered configurations for high availability (HA).

Before installing persistent memory modules, make sure that the following components and software are available:

- A supported HPE ProLiant Gen10 server or Synergy compute module using second-generation Intel Xeon Scalable processors. For more information, see the product QuickSpecs on the Hewlett Packard Enterprise website (<https://www.hpe.com/support/persistentmemoryQS>).
- HPE DDR4 Standard Memory RDIMMs or LRDIMMs (the number will vary based on your chosen configuration).
- Supported firmware and drives:
  - System ROM version 2.10 or later
  - Server Platform Services (SPS) Firmware version 04.01.04.296
  - HPE iLO 5 Firmware version 1.43
  - HPE Innovation Engine Firmware version 2.1.x or later

Download the required firmware and drivers from the Hewlett Packard Enterprise website (<https://www.hpe.com/info/persistentmemory>).

- A supported operating system:
  - Windows Server 2012 R2 with persistent memory drivers from Hewlett Packard Enterprise
  - Windows Server 2016 with persistent memory drivers from Hewlett Packard Enterprise
  - Windows Server 2019
  - Red Hat Enterprise Linux 7.6 and later

- Red Hat Enterprise Linux 8.0 and later
- SUSE Linux Enterprise Server 12 SP4 and later
- SUSE Linux Enterprise Server 15 with SUSE-SU-2019:0224-1 or later kernel update
- SUSE Linux Enterprise Server 15 SP1 with SUSE-SU-2019:1550-1 or later kernel update
- VMware vSphere 6.7 U2 + Express Patch 10 (ESXi670-201906002) or later (supports App Direct and Memory modes)
- VMware vSphere 6.5 U3 or later (supports Memory mode)
- Hardware and licensing requirements for optional encryption of the persistent memory modules:
  - HPE TPM 2.0 (local key encryption)
  - HPE iLO Advanced License (remote key encryption)
  - Key management server (remote key encryption)

For more information, see the Intel Optane persistent memory for HPE User Guide on the Hewlett Packard Enterprise website (<https://www.hpe.com/info/persistentmemory-docs>).

## Installing persistent memory modules

### Prerequisites

Before you perform this procedure, make sure that you have the following items available:

- The components included with the hardware option kit
- A T-10 Torx screwdriver might be needed to unlock the access panel.

### About this task

Use this procedure only for new persistent memory module installations. If you are migrating this persistent memory module from another server, see the Intel Optane persistent memory 100 series for HPE User Guide on the Hewlett Packard Enterprise website (<https://www.hpe.com/info/persistentmemory-docs>).

## Procedure

1. Observe the following alerts:



### CAUTION:

DIMMs and persistent memory modules are keyed for proper alignment. Align notches on the DIMM or persistent memory module with the corresponding notches in the slot before installing the component. Do not force the DIMM or persistent memory module into the slot. When installed properly, not all DIMMs or persistent memory modules will face in the same direction.



### CAUTION:

Electrostatic discharge can damage electronic components. Be sure you are properly grounded before beginning this procedure.



### CAUTION:

Failure to properly handle persistent memory modules can damage the component and the system board connector.



### IMPORTANT:

Hewlett Packard Enterprise recommends that you implement best-practice configurations such as clustered configurations for high availability (HA).

2. Power down the server ([Power down the server](#)).
3. Remove all power:
  - a. Disconnect each power cord from the power source.
  - b. Disconnect each power cord from the server.
4. Do one of the following:
  - a. Extend the server from the rack ([Extend the server from the rack](#)).
  - b. Remove the server from the rack ([Remove the server from the rack](#)).
5. Place the server on a flat, level work surface.
6. [Remove the access panel](#).
7. Open the DIMM slot latches.

8. Install the persistent memory module.

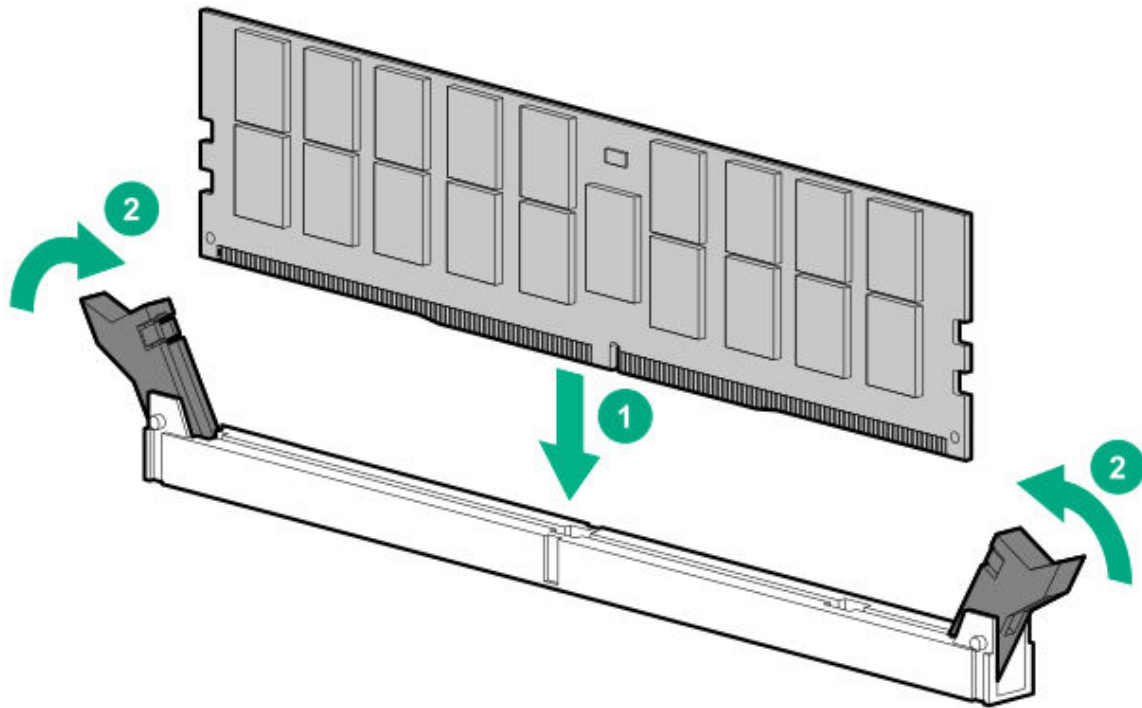

9. Install the access panel ([Install the access panel](#)).

10. Slide or install the server into the rack.

11. If removed, reconnect all power cables.

12. Power up the server.

13. [Configure the server for Intel Optane persistent memory for HPE.](#)

## Configuring the server for Intel Optane persistent memory 100 series for HPE

After installing persistent memory modules, configure the server for Intel Optane persistent memory for HPE.



### IMPORTANT:

Always follow recommendations from your software application provider for high-availability best practices to ensure maximum uptime and data protection.

A number of configuration tools are available, including:

- UEFI System Utilities—Configure the server by using the UEFI System Utilities through the Remote Console. To access the UEFI System Utilities, press **F9** during POST.
- iLO RESTful API—Use the iLO RESTful API through tools such as the RESTful Interface Tool (ilorest) or other third-party tools.

For more information, see the Intel Optane persistent memory 100 series for HPE User Guide on the Hewlett Packard Enterprise website (<https://www.hpe.com/info/persistentmemory-docs>).

## Installing a high-performance fan

### Prerequisites

Before installing this option, be sure you have the following:

The components included with the hardware option kit

### About this task

Certain hardware configurations require high-performance fans. To verify a specific configuration, see the product QuickSpecs on the Hewlett Packard Enterprise [website](#).

This kit meets extended ambient operating temperatures above 35 degrees Celsius. For more information about extended ambient configurations, see the [Hewlett Packard Enterprise website](#).

### Procedure

1. Observe the following alert:



**IMPORTANT:** After removing a high-performance (dual-rotor) fan, install or replace the fan within 60 seconds. Otherwise, the server will shut down gracefully.

2. Power down the server ([Power down the server](#)).
3. Remove all power:
  - a. Disconnect each power cord from the power source.
  - b. Disconnect each power cord from the server.
4. Do one of the following:
  - a. Extend the server from the rack ([Extend the server from the rack](#)).

- b. Remove the server from the rack (Remove the server from the rack).
5. Remove the access panel (Remove the access panel).
6. Remove all standard fans from the fan bays.

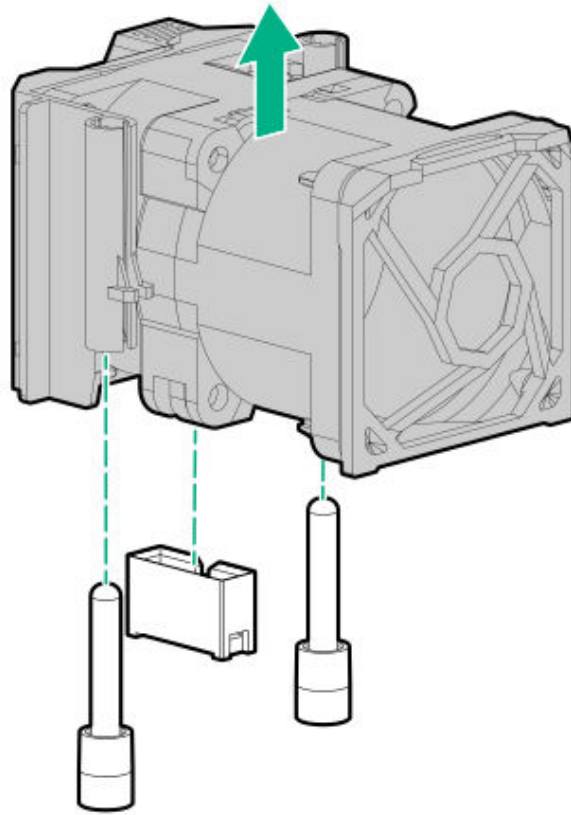

7. Remove fan blanks from the fan bays, if installed.

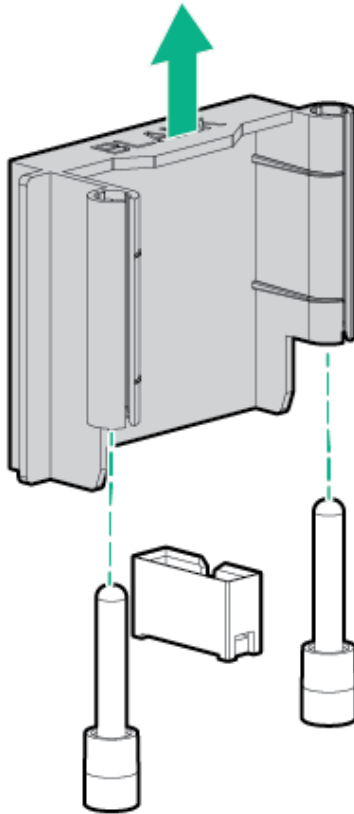

8. Install high-performance fans in each of the seven fan bays.

If needed, ensure each fan is securely installed by pressing the tab. Do not press on other areas of the fan.

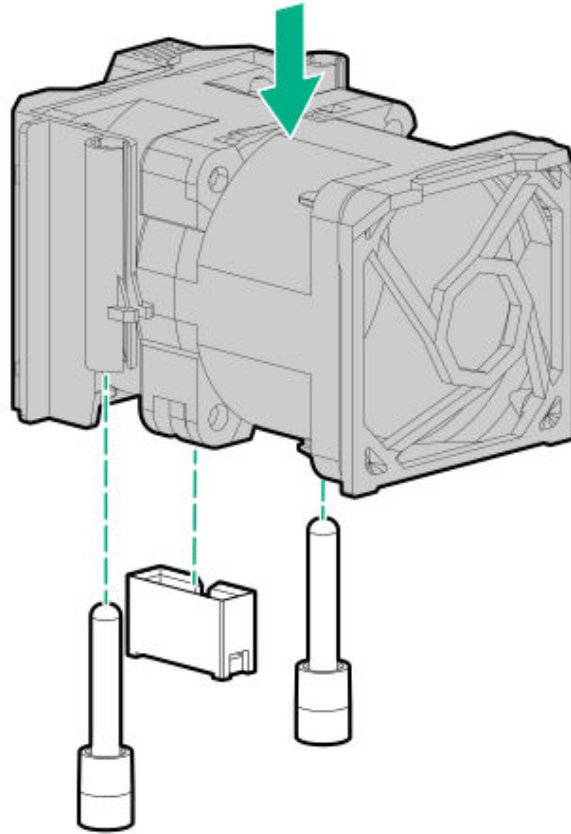

9. Install the access panel ([Install the access panel](#)).
10. Slide the server into the rack.
11. Connect each power cord to the server.
12. Connect each power cord to the power source.
13. Power up the server ([Power up the server](#)).

## Drive options

Depending on the configuration, this server supports SAS, SATA, NVMe, and M.2 drives. For more information on drive support, see the product [QuickSpecs](#).

When adding hard drives to the server, observe the following general guidelines:

- The system automatically sets all device numbers.
- For drive numbering, see [Drive bay numbering](#).
- If using only one hard drive, install it in the bay with the lowest device number.

- To provide the greatest storage space efficiency, group identical capacity drives into the same drive array.
- The NVMe SSD is a PCIe bus device. Do not remove NVMe drives without allowing the device to cease activity. Removing the drive while active can cause data loss.

## Subtopics

### **Hot-plug drive guidelines**

### **Removing the hard drive blank**

### **Installing a hot-plug SAS or SATA drive**

### **Removing a hot-plug SAS or SATA hard drive**

### **Installing the NVMe drives**

### **Removing and replacing an NVMe drive**

### **Installing a uFF drive and SCM drive carrier**

### **Removing and replacing a uFF drive**

### **Installing a hot-plug SAS/SATA basic drive**

### **Removing a hot-plug SAS/SATA basic drive**

### **Installing an 8 SFF optical drive**

## Hot-plug drive guidelines

When adding drives to the server, observe the following general guidelines:

- The system automatically sets all device numbers.
- If only one drive is used, install it in the bay with the lowest device number.
- Drives should be the same capacity to provide the greatest storage space efficiency when drives are grouped together into the same drive array.

## Removing the hard drive blank

### **About this task**

Remove the component as indicated.

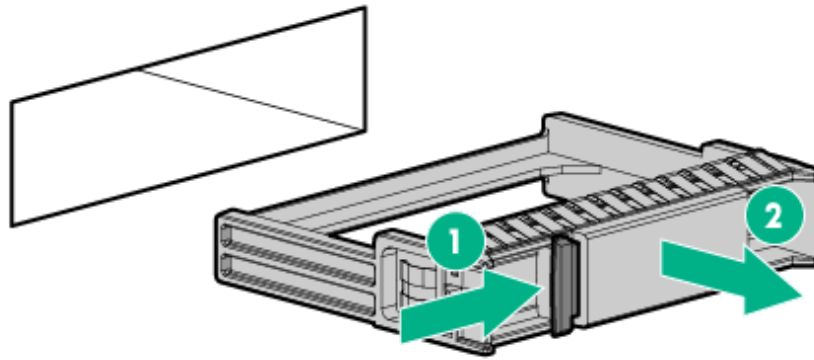

## Installing a hot-plug SAS or SATA drive

### Prerequisites

Before installing this option, be sure that you have the following:

The components included with the hardware option kit

### Procedure

1. Remove the drive blank.

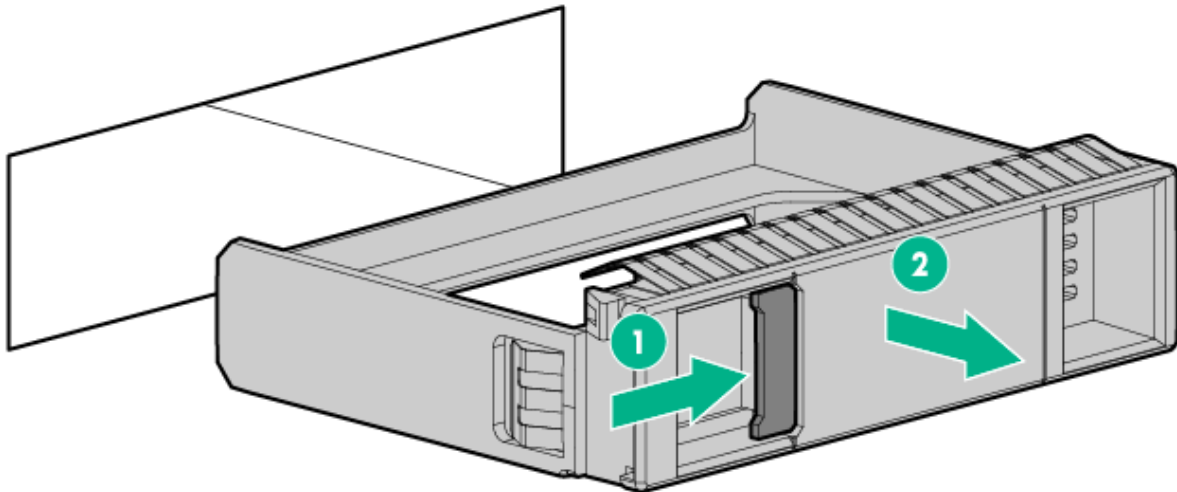

2. Prepare the drive.

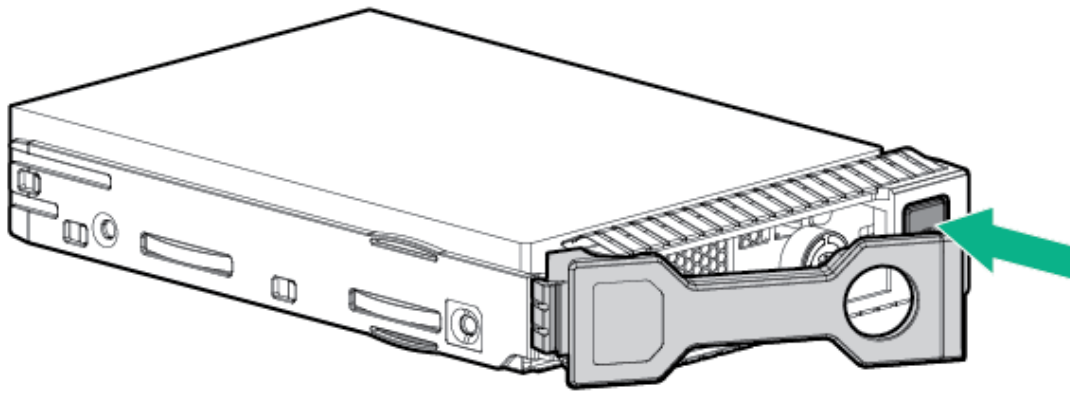

3. Install the drive.

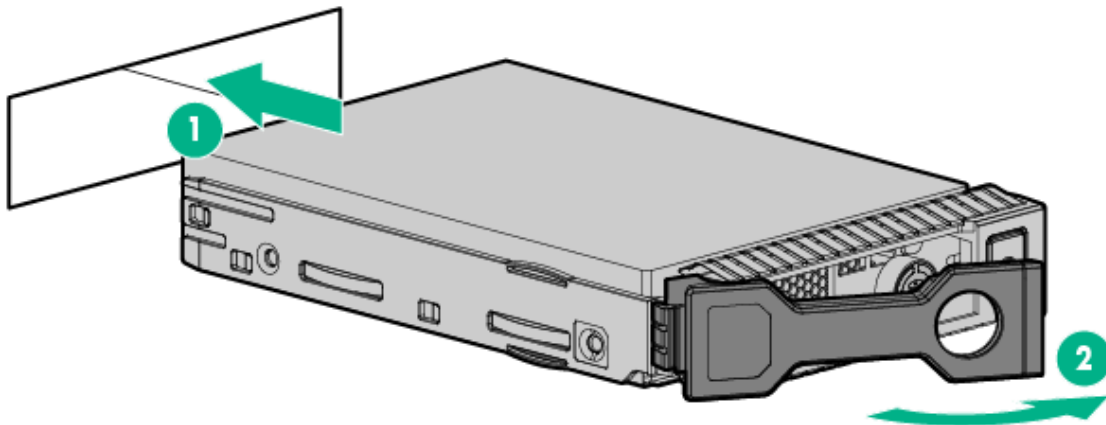

4. Determine the status of the drive from the drive LED definitions ([Hot-plug drive LED definitions](#)).

## Removing a hot-plug SAS or SATA hard drive



**CAUTION:** For proper cooling, do not operate the server without the access panel, baffles, expansion slot covers, or blanks installed. If the server supports hot-plug components, minimize the amount of time the access panel is open.

1. Determine the status of the drive from the [hot-plug drive LED definitions](#).
2. Back up all server data on the drive.

3. Remove the drive.

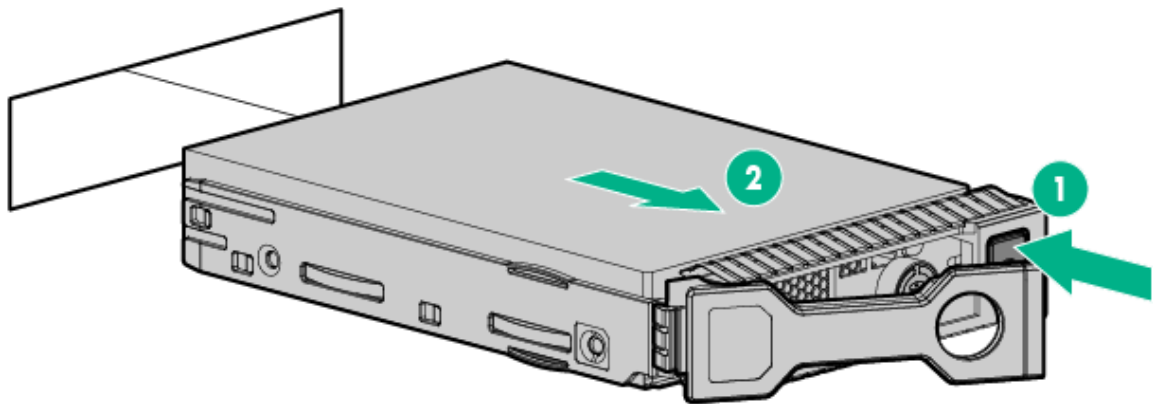

## Installing the NVMe drives

### Prerequisites

NVMe drives are supported in the 8SFF and 10 SFF server configurations. Before installing this option, be sure you have the following:

The components included with the hardware option kit

### About this task

NVMe drives are supported in 8 SFF and 10 SFF server configurations when the 10 SFF SAS/SATA/NVMe Combo backplane option or the 2 SFF NVMe backplane option is installed. When either backplane is installed, NVMe drives are required in bays 9 and 10. For more information, see [Device numbers](#).

### Procedure

1. Observe the following alert:



**CAUTION:** To prevent improper cooling and thermal damage, do not operate the server unless all bays are populated with either a component or a blank.

2. Remove the drive blank, if installed.

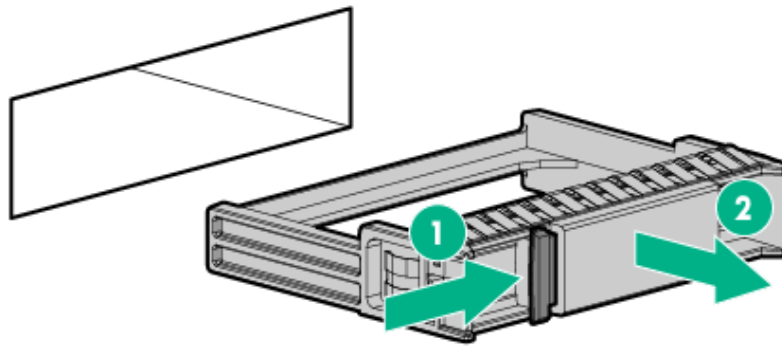

3. Press the Do Not Remove button to open the release handle.

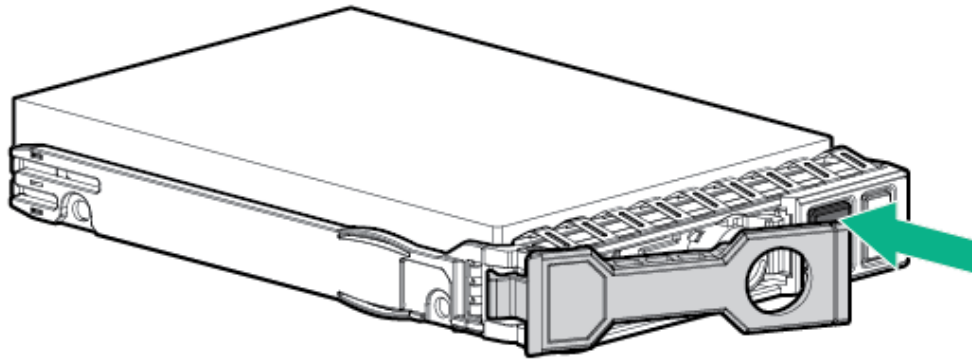

4. Install the drives.

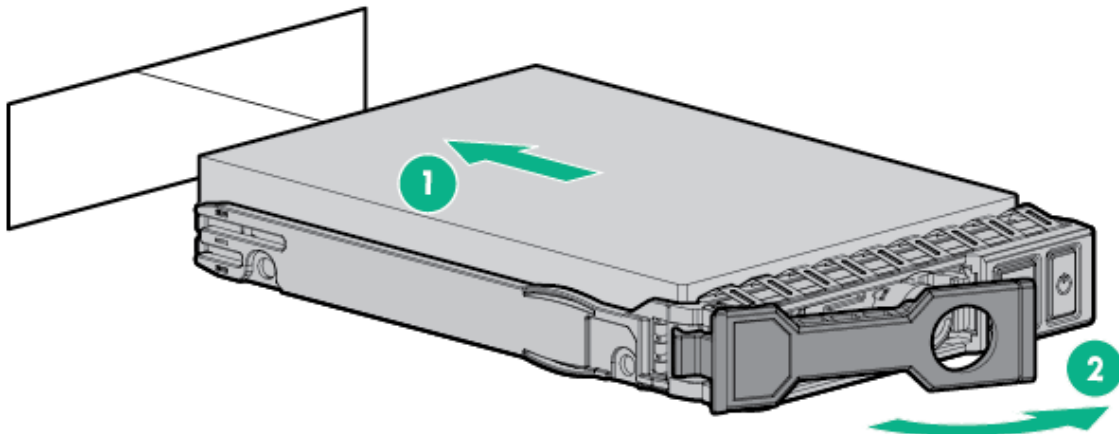

5. Install an SFF drive blank in any unused drive bays.



## Removing and replacing an NVMe drive

### About this task

An NVMe SSD is a PCIe BUS device. Devices attached to a PCIe bus cannot be removed without allowing the device and the bus to complete and cease signal/traffic flow.

### Procedure

1. Back up all server data.
2. Observe the LED status of the drive and determine if it can be removed.
3. Remove the drive:
  - a. Push the Power button.  
The Do Not Remove button illuminates and flashes.
  - b. Wait until the flashing stops and the Do Not Remove button is no longer illuminated.
  - c. Push the Do Not Remove button and then remove the drive.

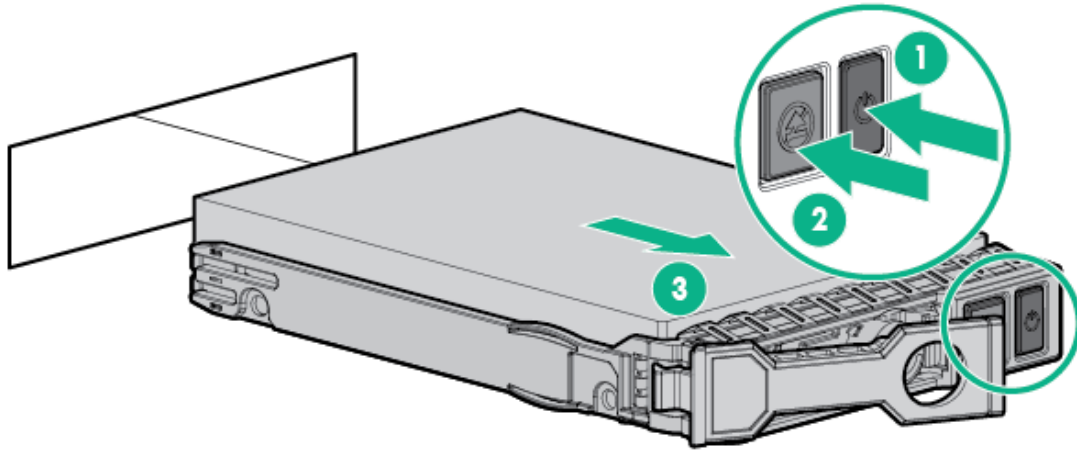

## Installing a uFF drive and SCM drive carrier

### About this task



**IMPORTANT:** Not all drive bays support the drive carrier. To find supported bays, see the server QuickSpecs on the Hewlett Packard Enterprise website (<https://www.hpe.com/info/qs>).

### Procedure

1. If needed, install the uFF drive into the drive carrier.

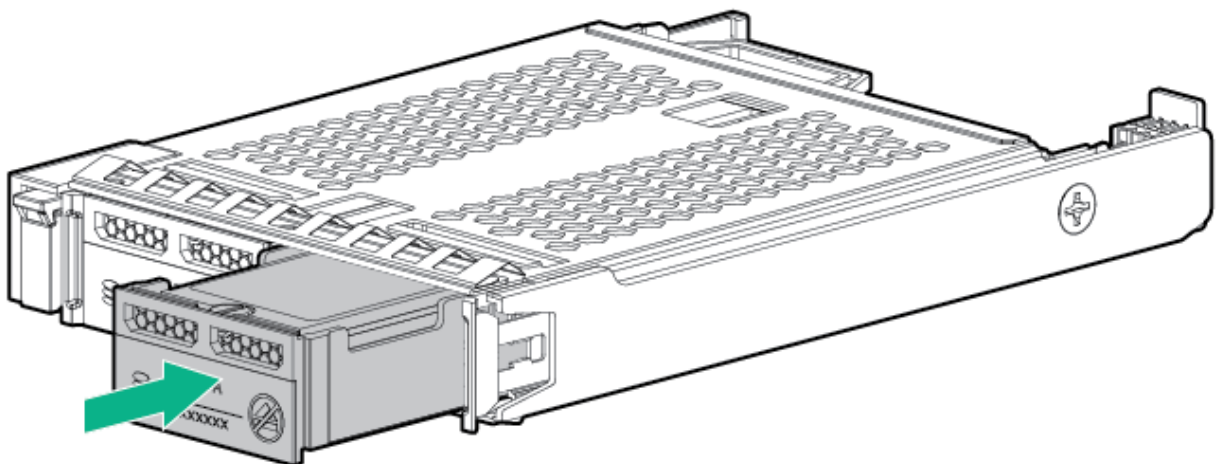

2. Remove the drive blank.

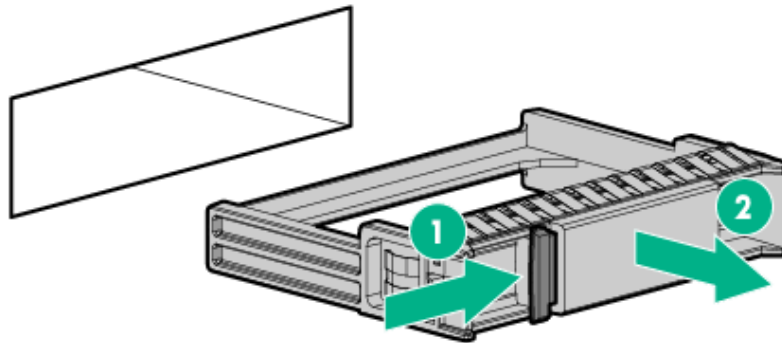

3. Install the drives.

Push firmly near the ejection handle until the latching spring engages with the drive bay.

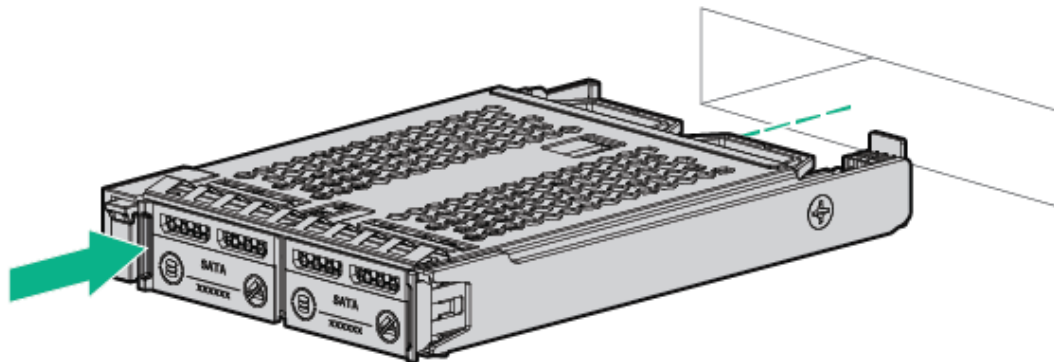

4. Power on the server.

To configure the drive, use [HPE Smart Storage Administrator](#).

## Removing and replacing a uFF drive

### Procedure

1. Back up all server data.

2. Observe the LED status of the drive and determine if it can be removed.
3. Remove the drive.

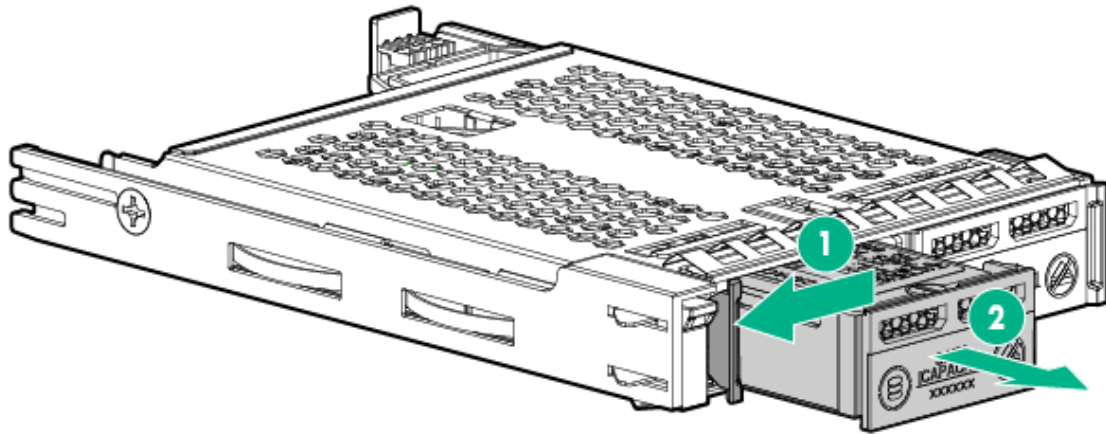

To remove the drive carrier:

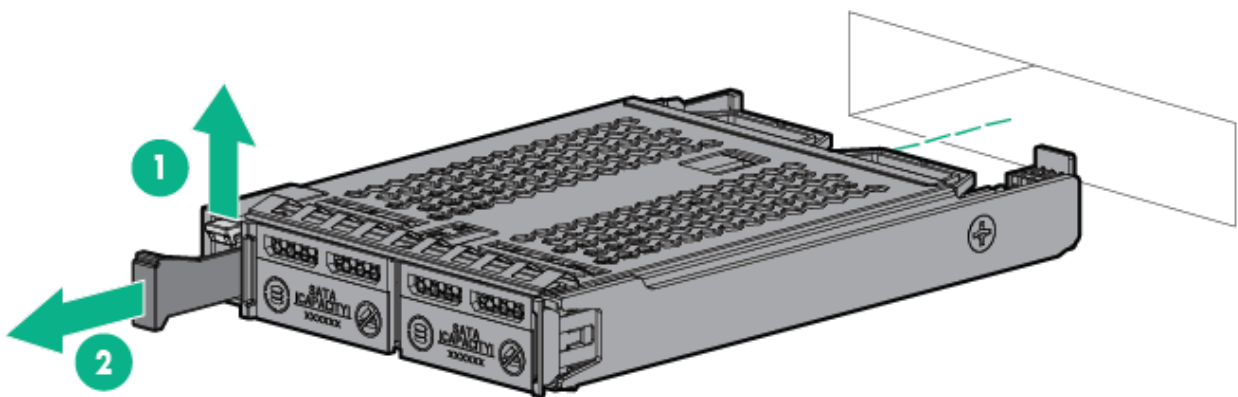

## Results

To replace the component, reverse the removal procedure.

## Installing a hot-plug SAS/SATA basic drive

### About this task



**CAUTION:** To prevent improper cooling and thermal damage, do not operate the server unless all drive and device bays are populated with either a component or a blank.

### Procedure

1. Remove the drive blank:

- LFF drive blank

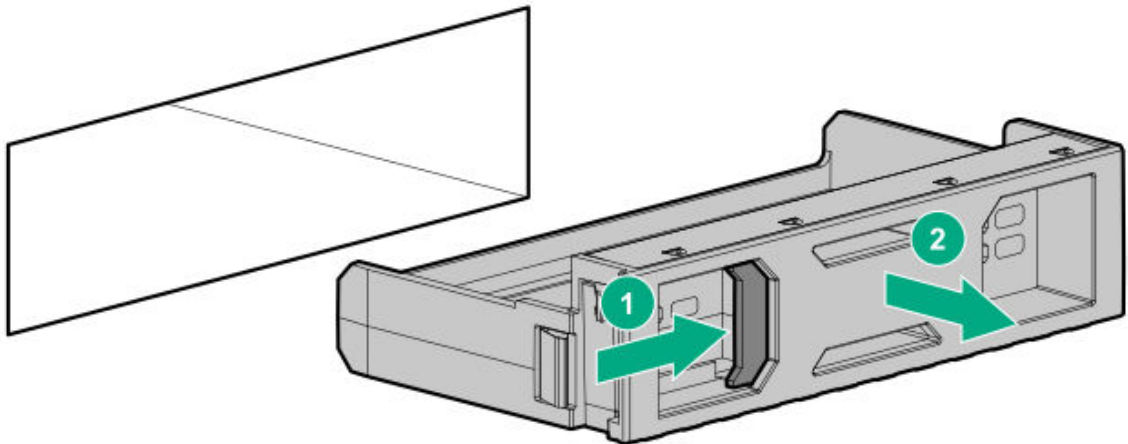

- SFF drive blank

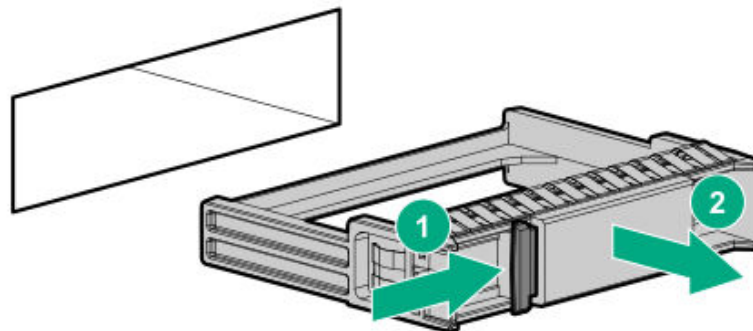

2. Prepare the drive.

- LFF drive

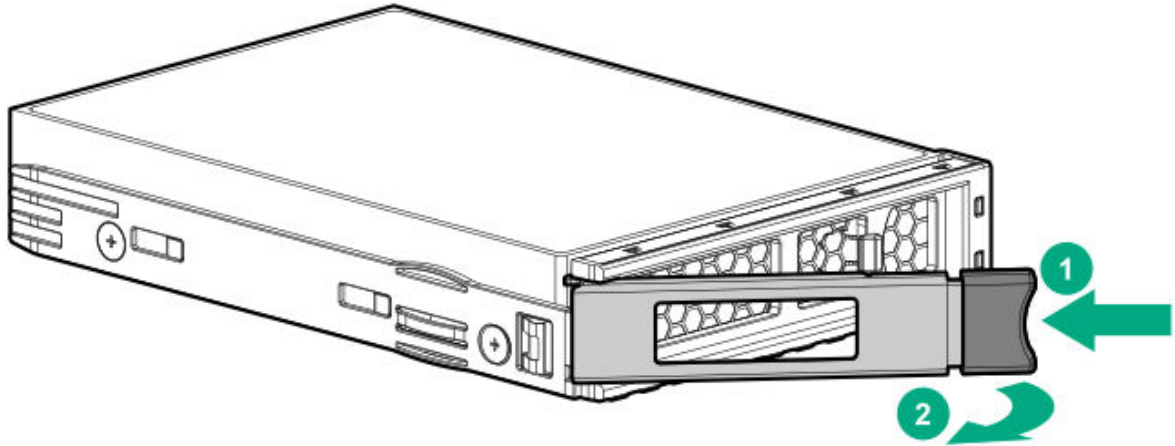

- SFF drive

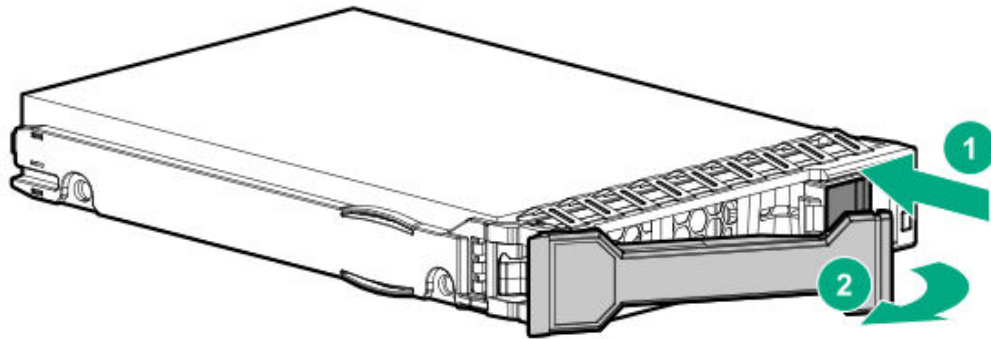

3. Install the drive.

- LFF drive

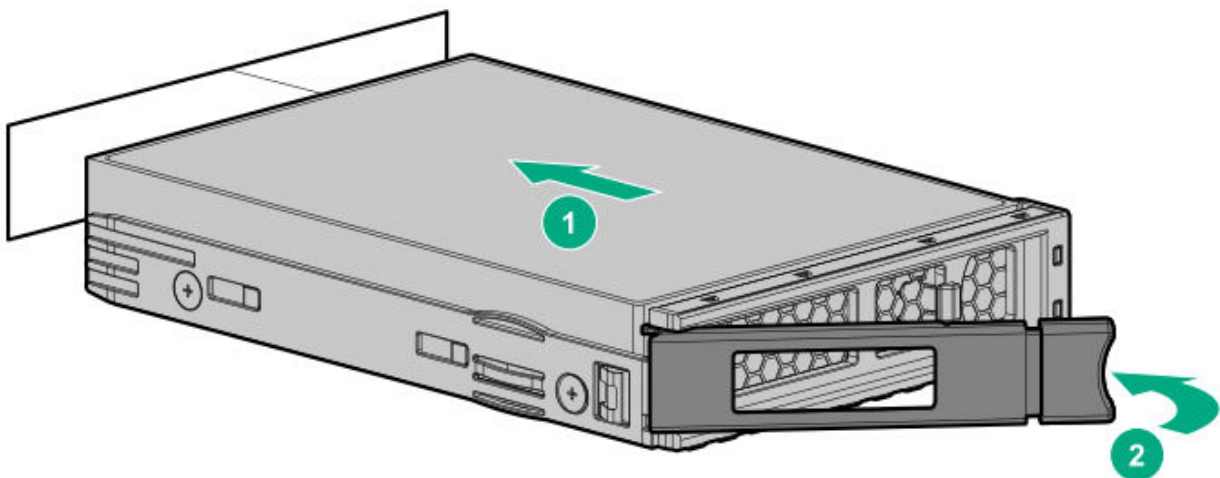

- SFF drive

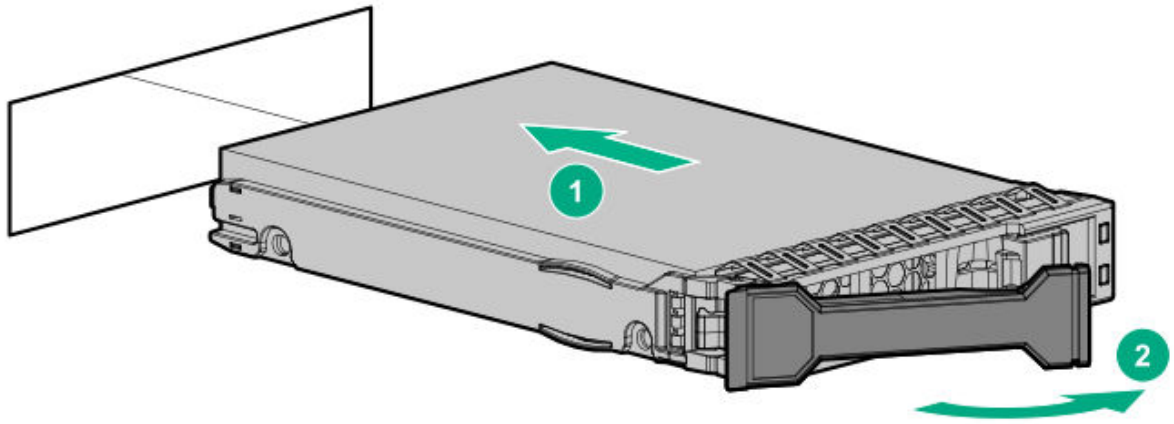

4. Determine the status of the drive from the drive LED definitions.

## Removing a hot-plug SAS/SATA basic drive



**CAUTION:** For proper cooling, do not operate the server without the access panel, baffles, expansion slot covers, or blanks installed. If the server supports hot-plug components, minimize the amount of time the access panel is open.

1. Determine the status of the drive from the hot-plug drive LED definitions.
2. Back up all server data on the drive.
3. Remove the drive.

**Figure 1. SFF drive**

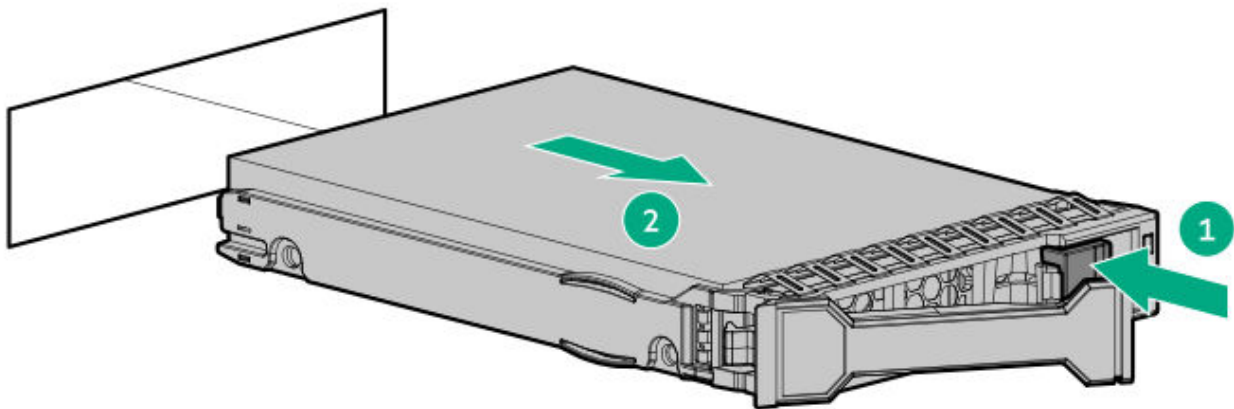

**Figure 2. LFF drive**

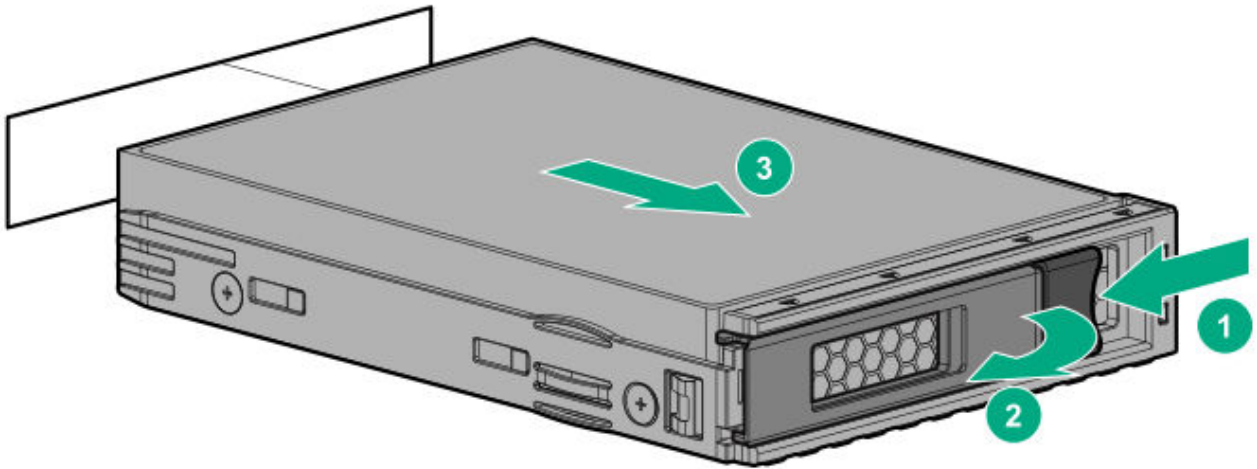

## Installing an 8 SFF optical drive

### Prerequisites

Before installing an optical drive, be sure the 8 SFF display port/USB/optical blank option is installed. For more information, see [Installing an 8 SFF display port/USB/optical blank option](#).

### Procedure

1. Remove the optical drive blank.

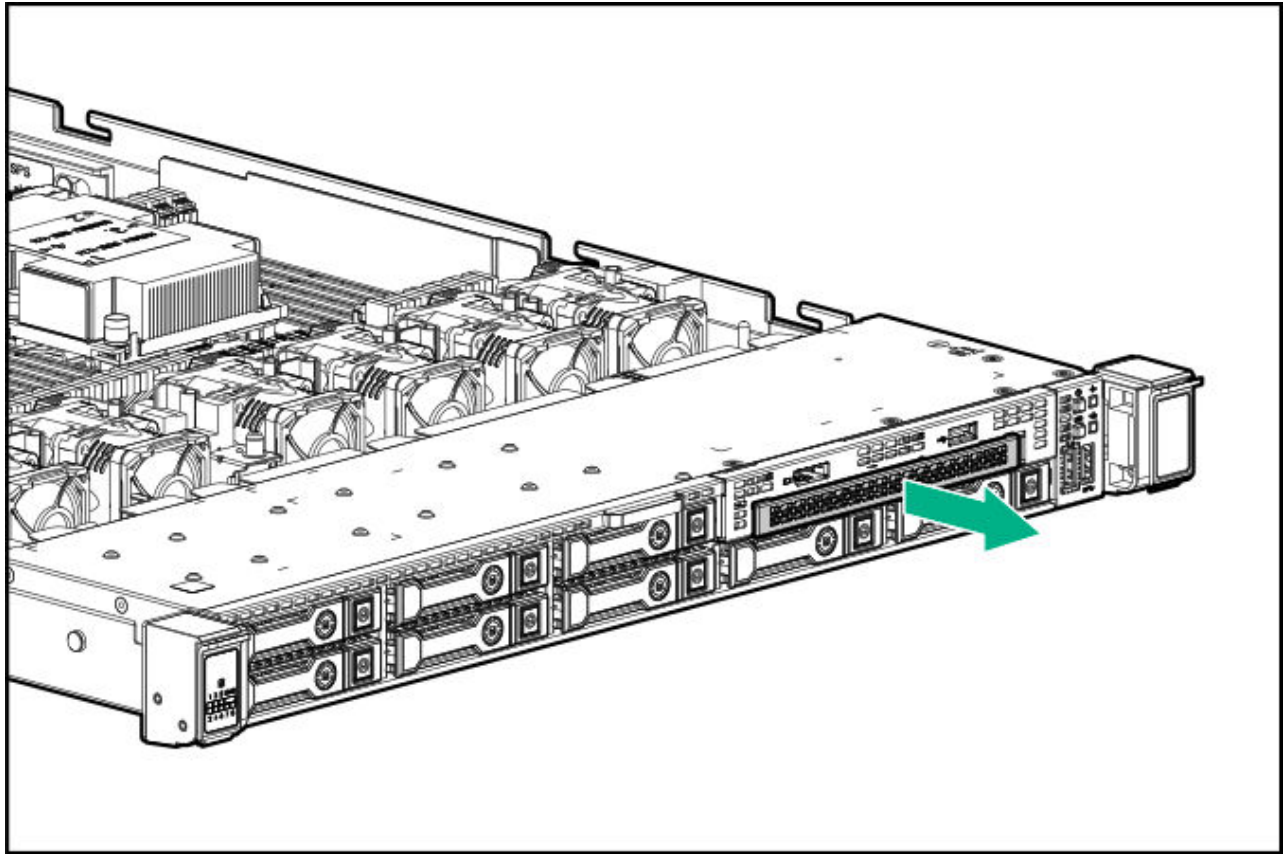

2. Install the optical drive.

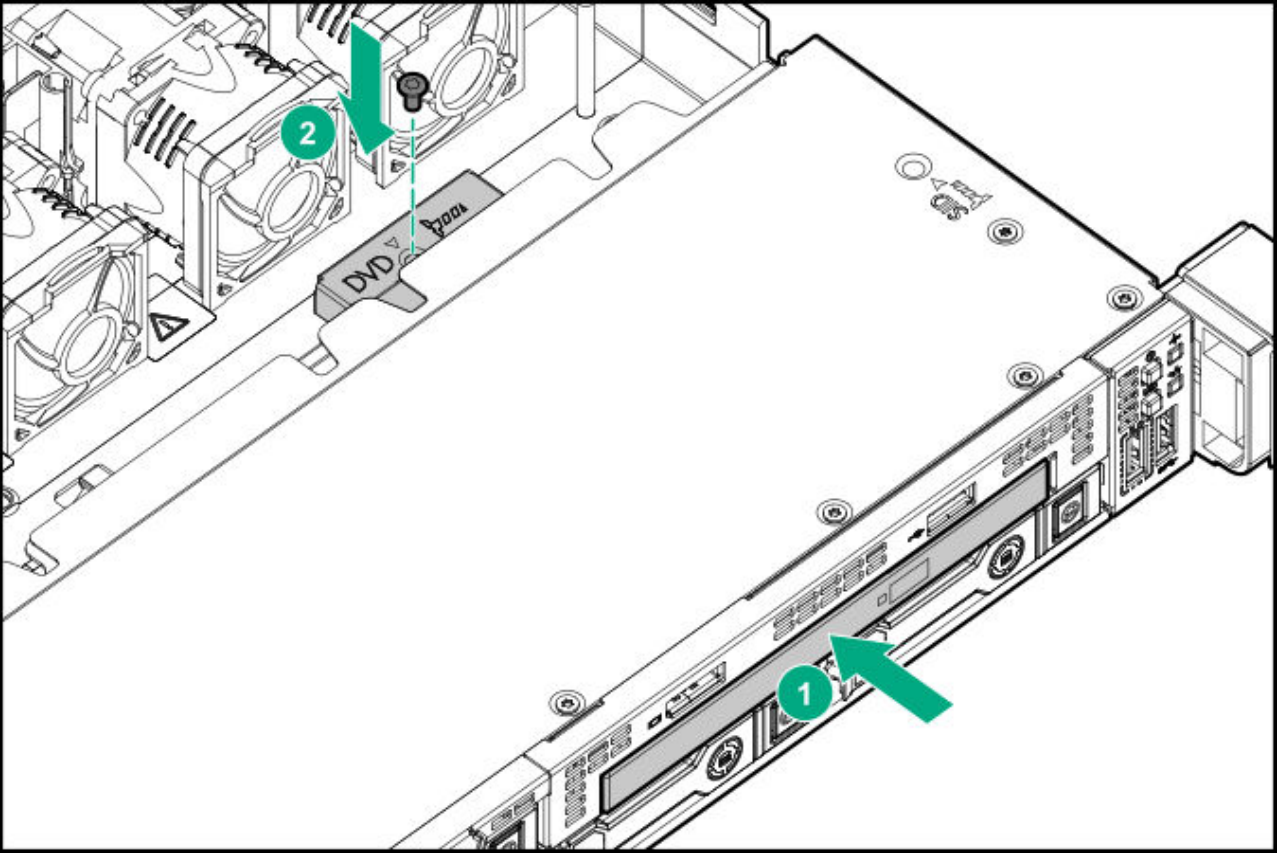

3. Connect the optical drive cable.

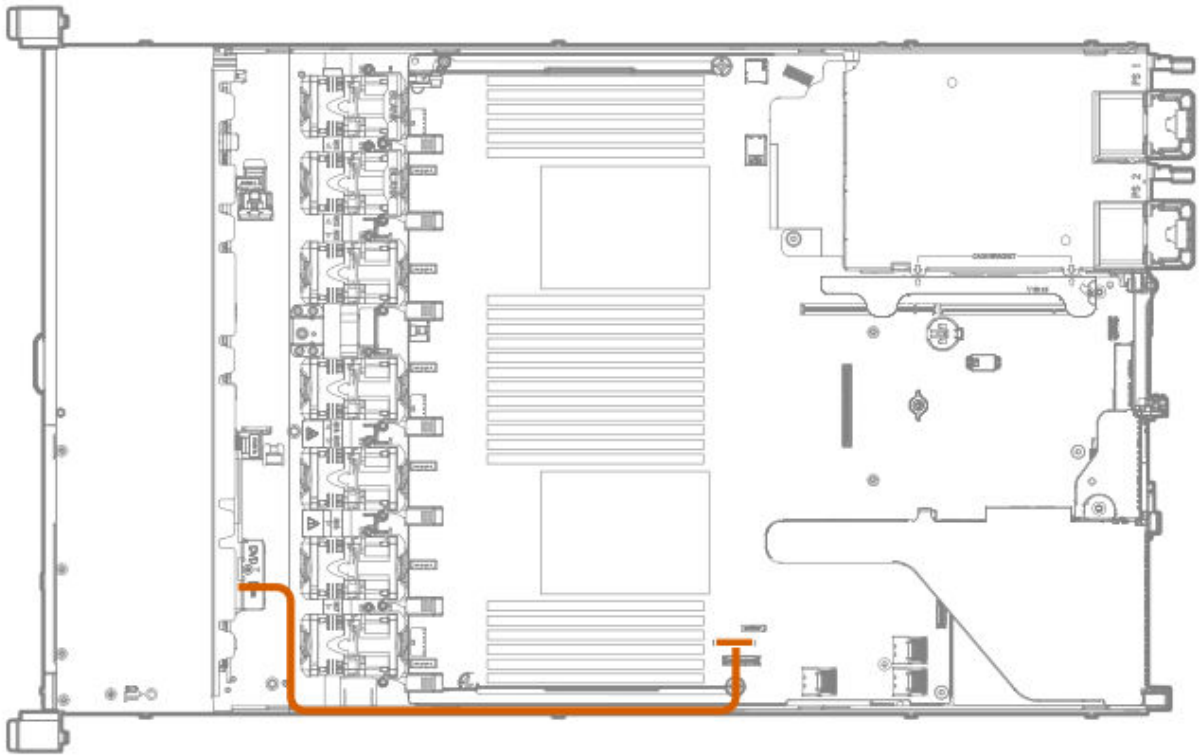

## Universal media bay options

### Subtopics

[Installing a 2 SFF SAS/SATA drive cage](#)

[Installing a 2 SFF NVMe drive cage option](#)

[Installing a 2 SFF HPE Smart Carrier M.2 \(SCM\) drive cage](#)

[Installing an 8 SFF display port/USB/optical blank option](#)

## Installing a 2 SFF SAS/SATA drive cage

### Prerequisites

Universal media bay options are compatible only with the 8 SFF chassis.

Hewlett Packard Enterprise recommends installing the P816i-a controller to support 10 SAS/SATA drives. For more information, see [Installing an HPE Smart Array P816i-a SR Gen10 Controller option](#).

Additional controller options are available. For more information, see the HPE DL360 Gen10 Server cabling matrix on the Hewlett Packard Enterprise website (<https://www.hpe.com/info/CablingMatrixGen10>).

In addition, be sure that you have the following:

- The components included with the hardware option kit
- T-10 Torx screwdriver
- Additional cables, as needed. For more information, see [SFF cables](#).
- 2 SFF SAS or SATA drives or blanks

For more information, contact a Hewlett Packard Enterprise authorized reseller.

### **Procedure**

1. Back up all server data.
2. [Power down the server](#).
3. Remove all power:
  - a. Disconnect each power cord from the power source.
  - b. Disconnect each power cord from the server.
4. Do one of the following:
  - a. [Extend the server from the rack](#).
  - b. [Remove the server from the rack](#).
5. [Remove the access panel](#).
6. Remove the universal media bay blank.

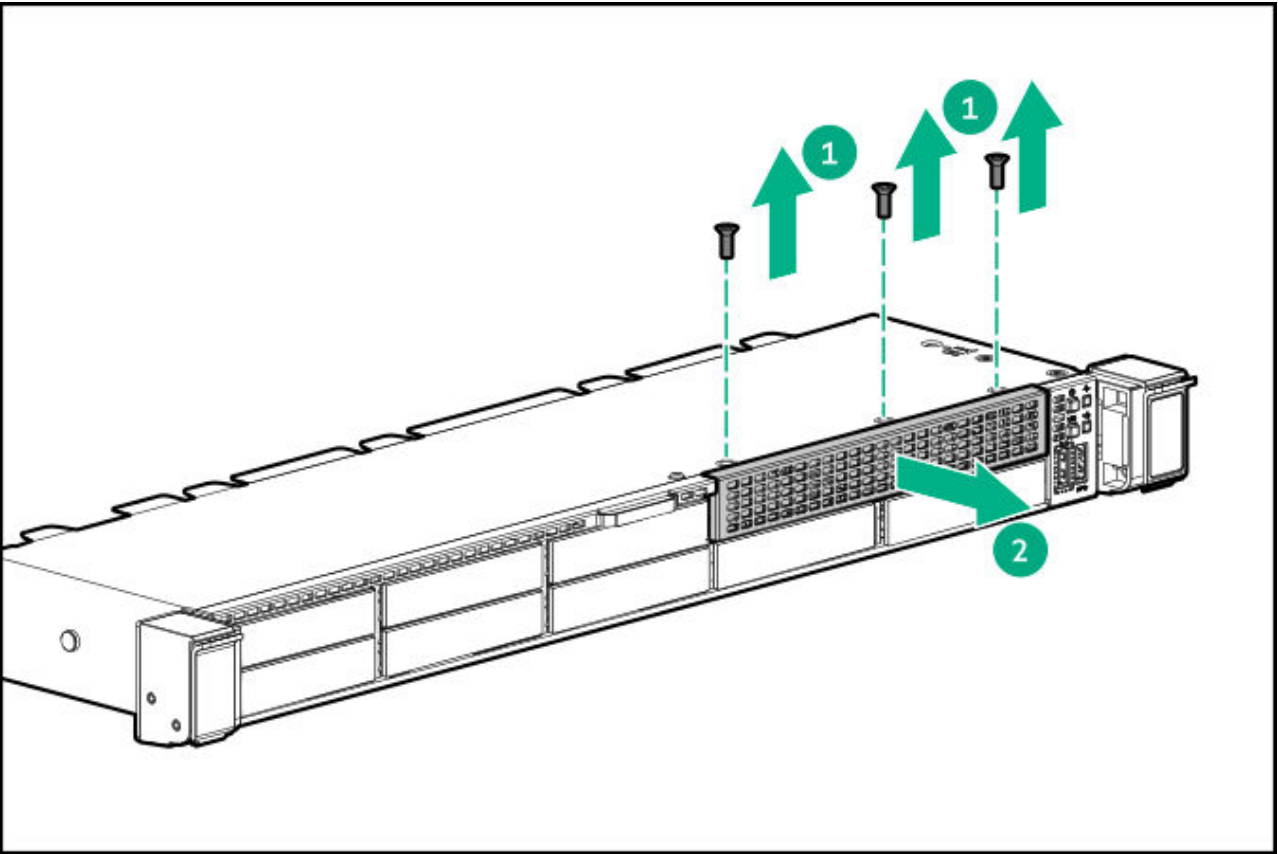

7. Install the 2 SFF SAS/SATA drive cage.

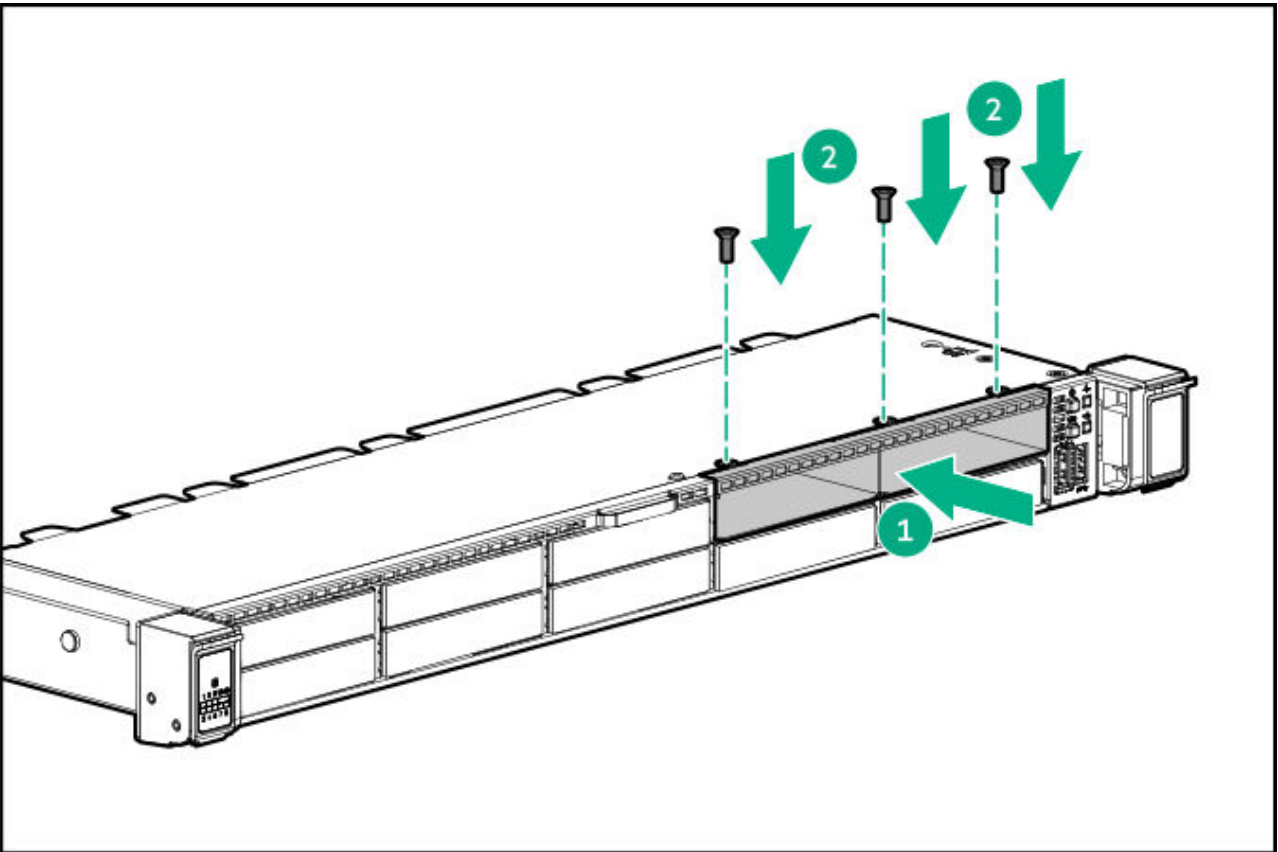

8. Observe the following:



**NOTE:**

The following information describes the standard cable routing for this component. For more information on optional cable routing, see the HPE ProLiant DL360 Gen10 Server cabling matrix on the Hewlett Packard Enterprise website (<https://www.hpe.com/info/CablingMatrixGen10>).

9. Route and connect the data cable.



10. Route and connect the power cable.

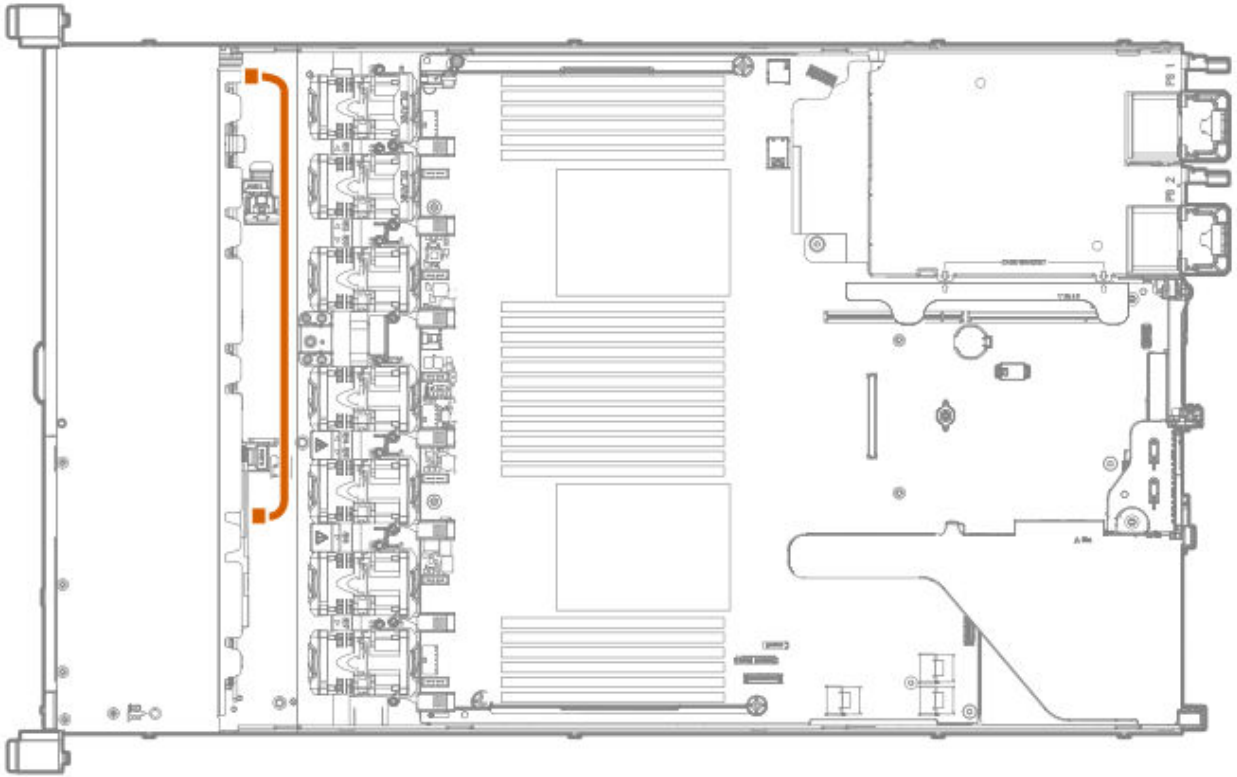

- .1. Install the access panel.
- .2. Install the server in the rack.
- .3. Connect each power cord to the server.
- .4. Connect each power cord to the power source.
- .5. Power up the server.
- .6. Install drives.

## Installing a 2 SFF NVMe drive cage option

### Prerequisites

Before installing this option, be sure that you have the following:

- The components included with the hardware option kit
- T-10 Torx screwdriver

- T-15 Torx screwdriver
- Additional cables, as needed. For more information, see [SFF cables](#).
- NVMe drives

For more information, contact a Hewlett Packard Enterprise authorized reseller.

### **Procedure**

1. Back up all server data.
2. Power down the server ([Power down the server](#)).
3. Remove all power:
  - a. Disconnect each power cord from the power source.
  - b. Disconnect each power cord from the server.
4. Do one of the following:
  - a. Extend the server from the rack ([Extend the server from the rack](#)).
  - b. Remove the server from the rack ([Remove the server from the rack](#)).
5. Remove the access panel ([Remove the access panel](#)).
6. Use a T-10 Torx screwdriver to remove the universal media bay blank.

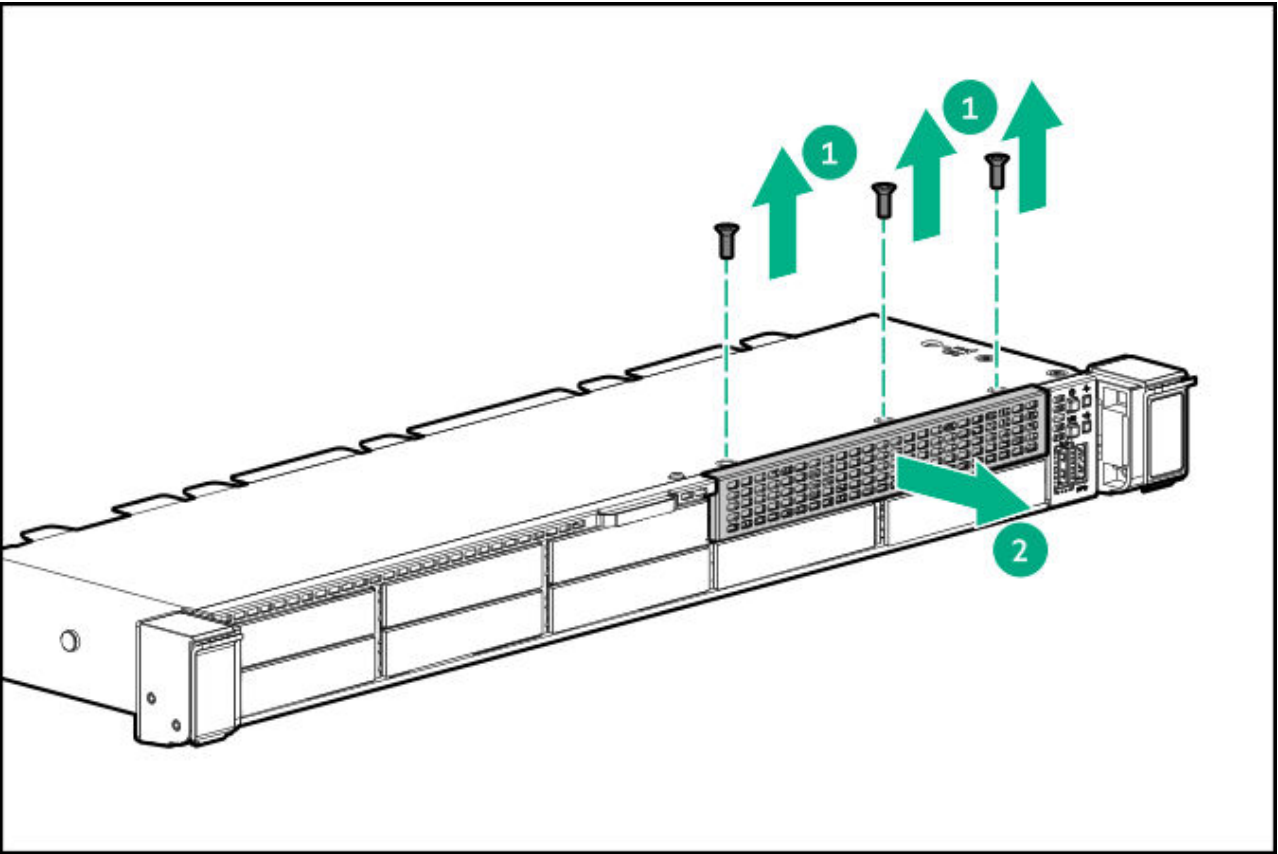

7. Use a T-10 Torx screwdriver to install the 2 SFF NVMe drive cage.

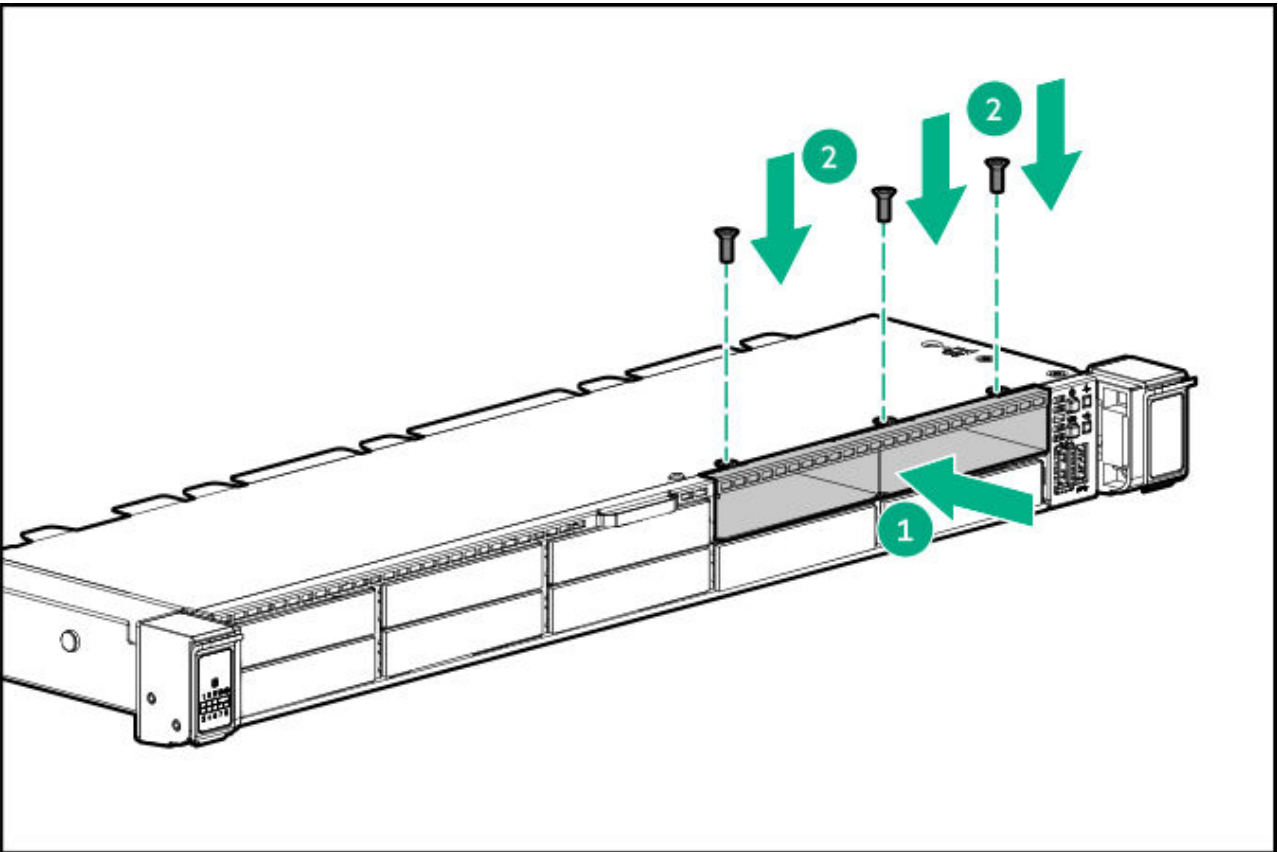

8. Remove the primary PCI riser cage (Remove the primary PCI riser cage).
9. Use a T-15 Torx screwdriver to remove the existing riser board.

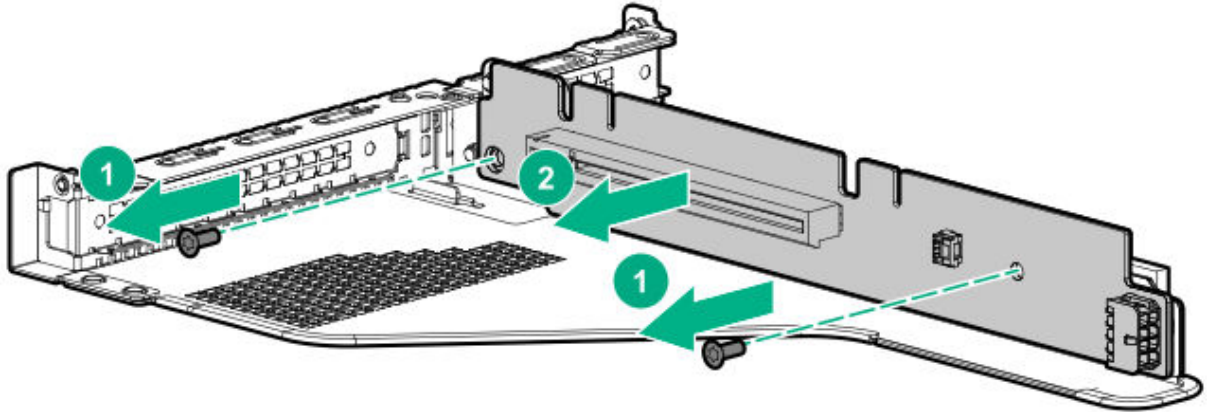

10. Use a T-15 Torx screwdriver to install the riser provided in the kit in the primary PCI riser cage.

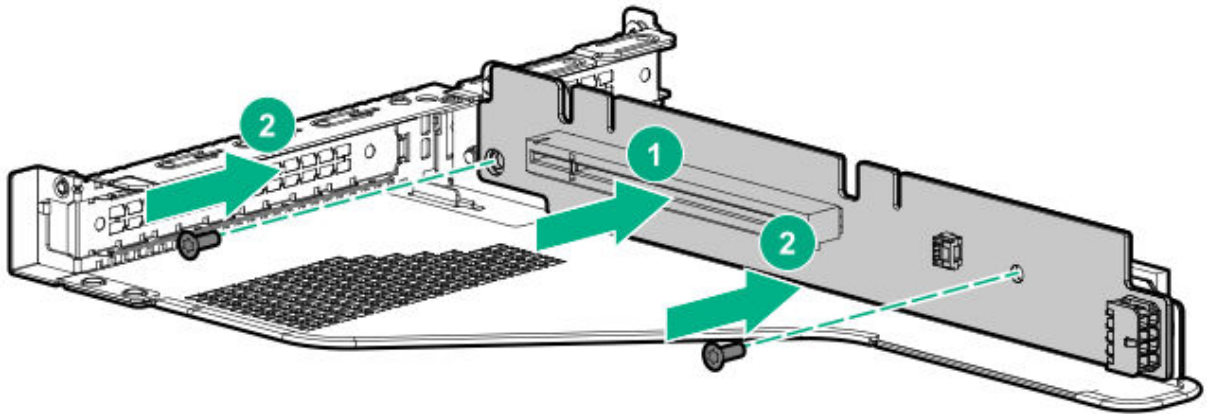

11. Observe the following:



**NOTE:**

The following information describes the standard cable routing for this component. For more information on optional cable routing, see the HPE ProLiant DL360 Gen10 Server cabling matrix on the Hewlett Packard Enterprise website (<https://www.hpe.com/info/CablingMatrixGen10>).

- .2. Route and connect the data cable.

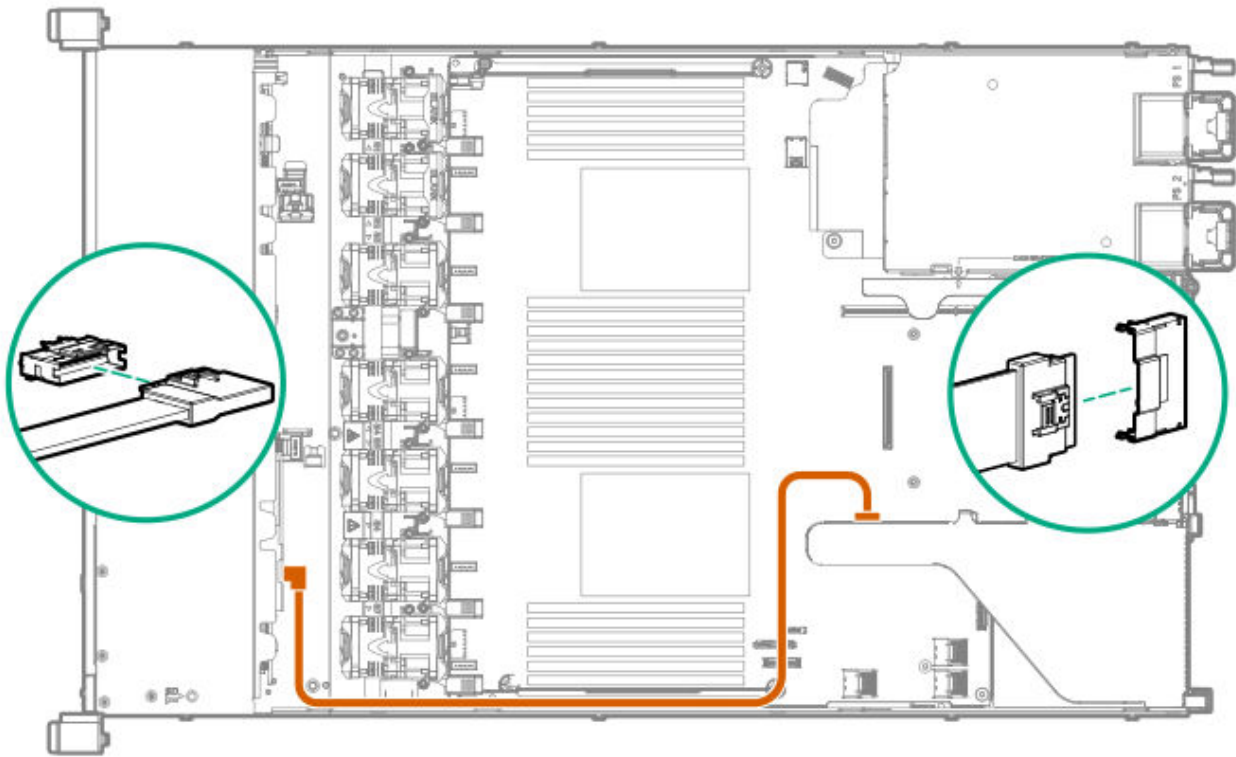

- .3. Install the primary PCI riser cage.
- .4. Install the access panel ([Install the access panel](#)).
- .5. Install the server in the rack.
- .6. Connect each power cord to the server.
- .7. Connect each power cord to the power source.
- .8. Power up the server ([Power up the server](#)).
- .9. Install drives.

## Installing a 2 SFF HPE Smart Carrier M.2 (SCM) drive cage

### Prerequisites

Hewlett Packard Enterprise recommends [installing the P816i-a controller](#) to support more than eight SAS/SATA drives. Additional controller options are available. For more information, see the HPE

DL360 Gen10 Server cabling matrix on the Hewlett Packard Enterprise (<https://www.hpe.com/info/CablingMatrixGen10>).

Before installing this option, be sure you that have the following:

- The components included with the hardware option kit
- T-10 Torx screwdriver
- Additional cables, as needed. For more information, see [SFF cables](#).
- 2 SFF SAS/SATA drives, 4 uFF M.2 drives, or blanks

For more information, contact a Hewlett Packard Enterprise authorized reseller.

### **Procedure**

1. Back up all server data.
2. [Power down the server](#).
3. Remove all power:
  - a. Disconnect each power cord from the power source.
  - b. Disconnect each power cord from the server.
4. Do one of the following:
  - a. [Extend the server from the rack](#).
  - b. [Remove the server from the rack](#).
5. [Remove the access panel](#).
6. Remove the universal media bay blank.

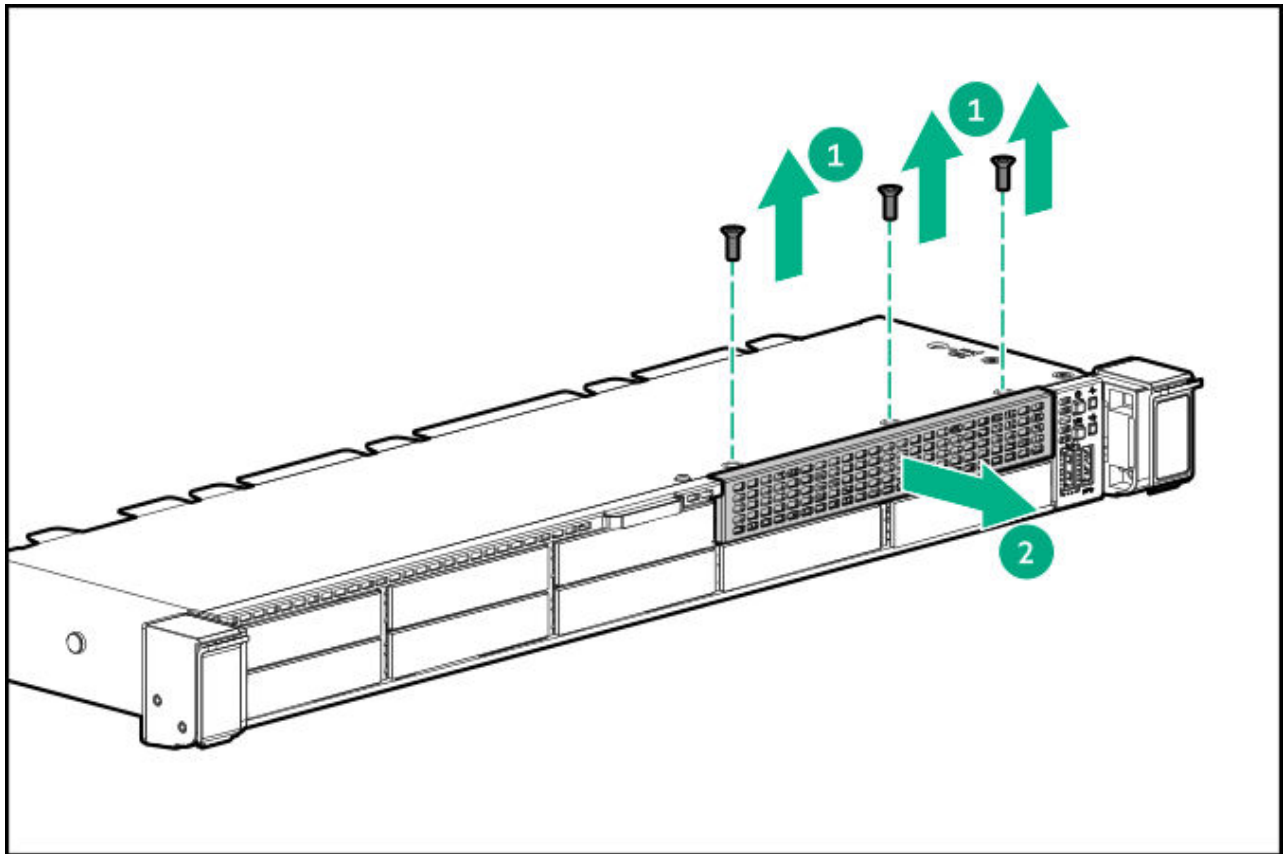

7. Install the drive cage.

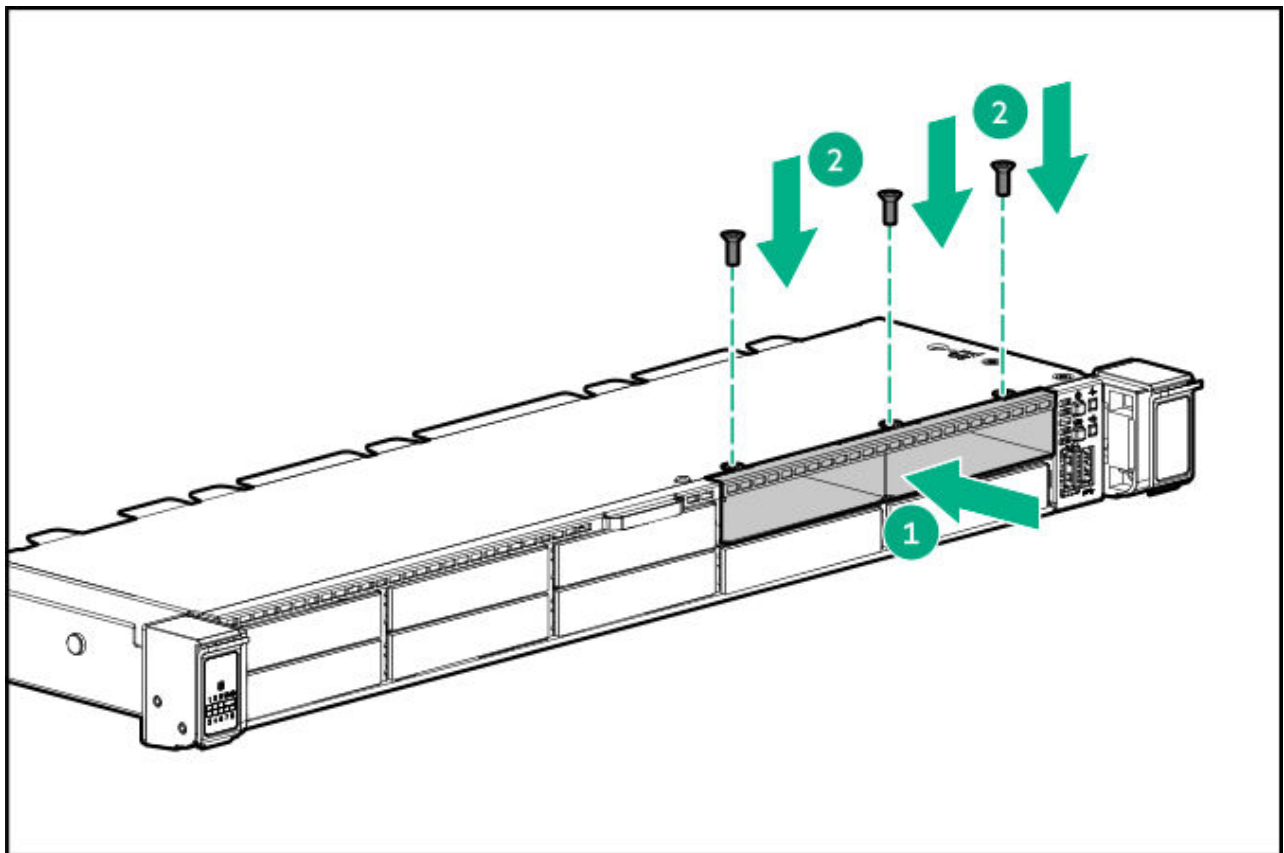

8. Observe the following:



**NOTE:**

The following information describes the standard cable routing for this component. For more information on optional cable routing, see the HPE ProLiant DL360 Gen10 Server cabling matrix on the Hewlett Packard Enterprise website (<https://www.hpe.com/info/CablingMatrixGen10>).

9. Route and connect the data cable.



10. Route and connect the power cable.

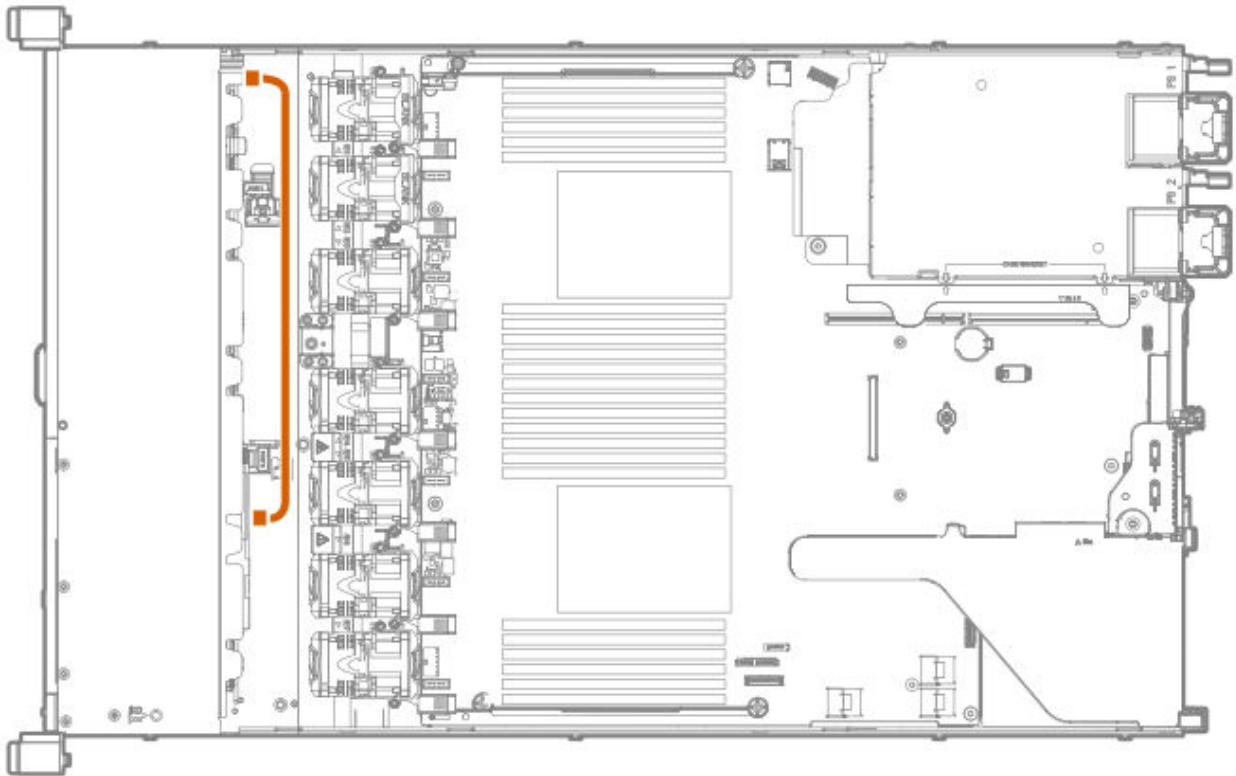

- .1. Install the access panel.
- .2. Install the server in the rack.
- .3. Connect each power cord to the server.
- .4. Connect each power cord to the power source.
- .5. Power up the server.
- .6. Install drives.

## Installing an 8 SFF display port/USB/optical blank option

### Prerequisites

Before installing this option, be sure that you have the following:

- The components included with the hardware option kit
- T-10 Torx screwdriver

- An optical drive, if installing

For more information, contact a Hewlett Packard Enterprise authorized reseller.

### Procedure

1. Back up all server data.
2. Power down the server ([Power down the server](#)).
3. Remove all power:
  - a. Disconnect each power cord from the power source.
  - b. Disconnect each power cord from the server.
4. Do one of the following:
  - a. Extend the server from the rack ([Extend the server from the rack](#)).
  - b. Remove the server from the rack ([Remove the server from the rack](#)).
5. Remove the access panel ([Remove the access panel](#)).
6. Remove the universal media bay blank.

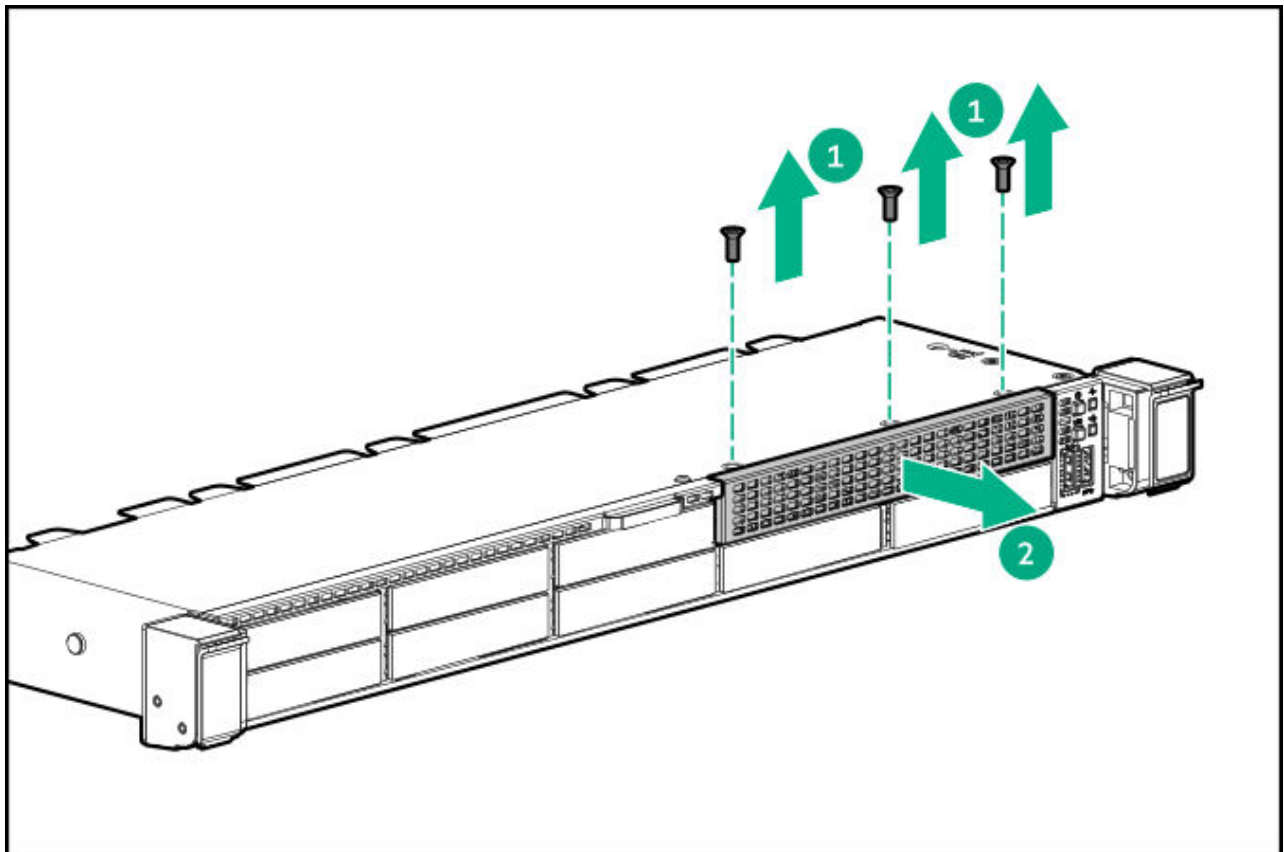

7. Install the 8 SFF display port/USB/optical blank option.

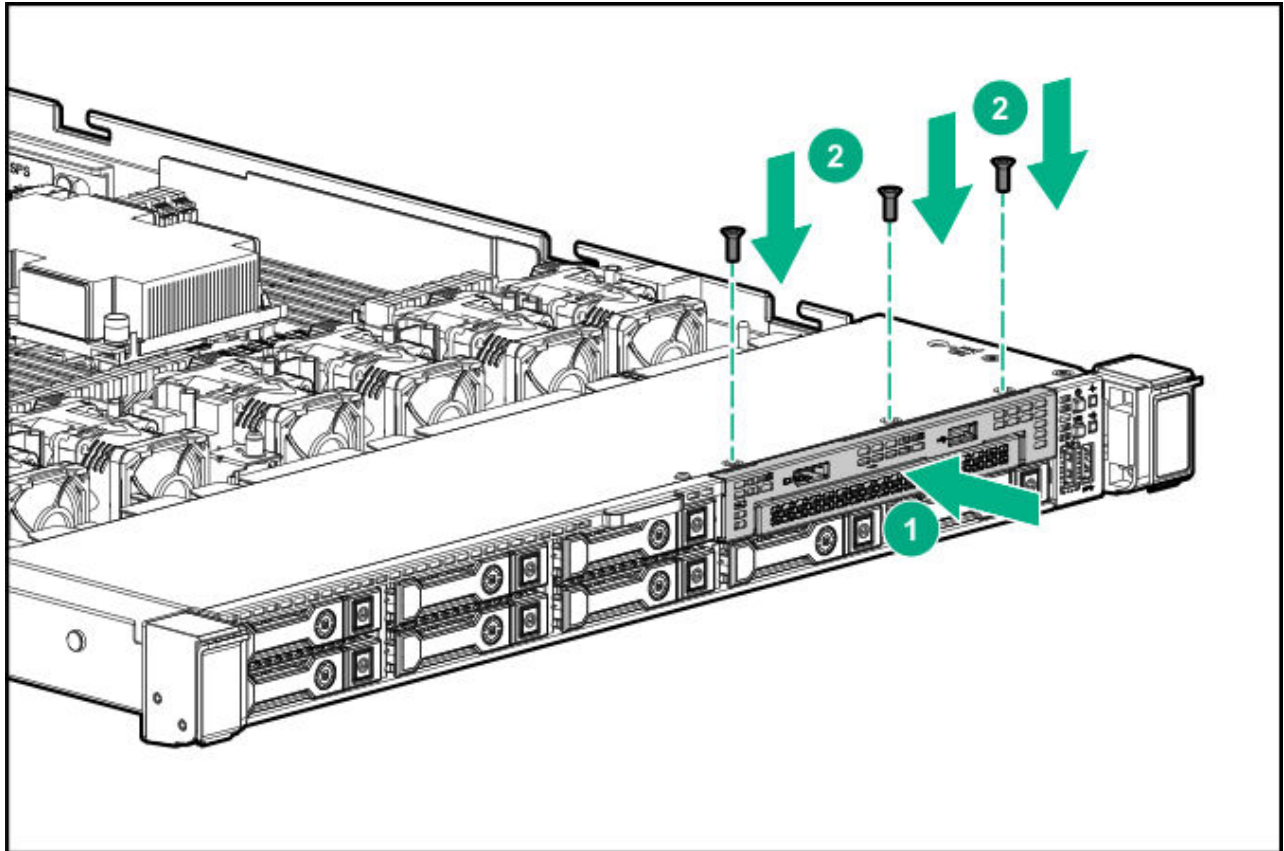

8. Route and connect the data cable.

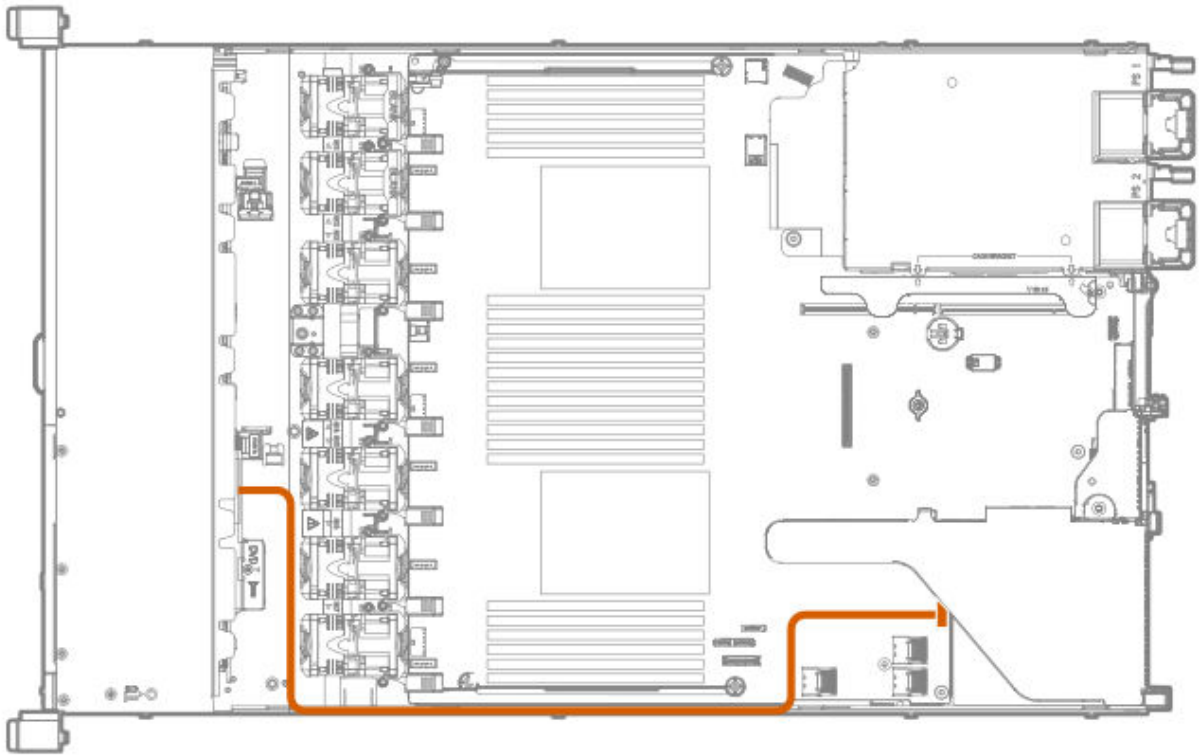

9. If needed, install an optical drive ([Installing an 8 SFF optical drive](#)).
0. Install the access panel ([Install the access panel](#)).
- .1. Install the server in the rack.
- .2. Connect each power cord to the server.
- .3. Connect each power cord to the power source.
- .4. Power up the server ([Power up the server](#)).

## Installing the 4 LFF optical drive option

### Prerequisites

Before installing this option, be sure that you have the following:

- The components included with the hardware option kit
- T-10 Torx screwdriver

- LFF optical cable option kit
- An optical drive

For more information, contact a Hewlett Packard Enterprise authorized reseller.

### Procedure

1. Back up all server data.
2. Power down the server ([Power down the server](#)).
3. Remove all power:
  - a. Disconnect each power cord from the power source.
  - b. Disconnect each power cord from the server.
4. Do one of the following:
  - a. Extend the server from the rack ([Extend the server from the rack](#)).
  - b. Remove the server from the rack ([Remove the server from the rack](#)).
5. Remove the access panel ([Remove the access panel](#)).
6. Remove the LFF optical drive bay blank.

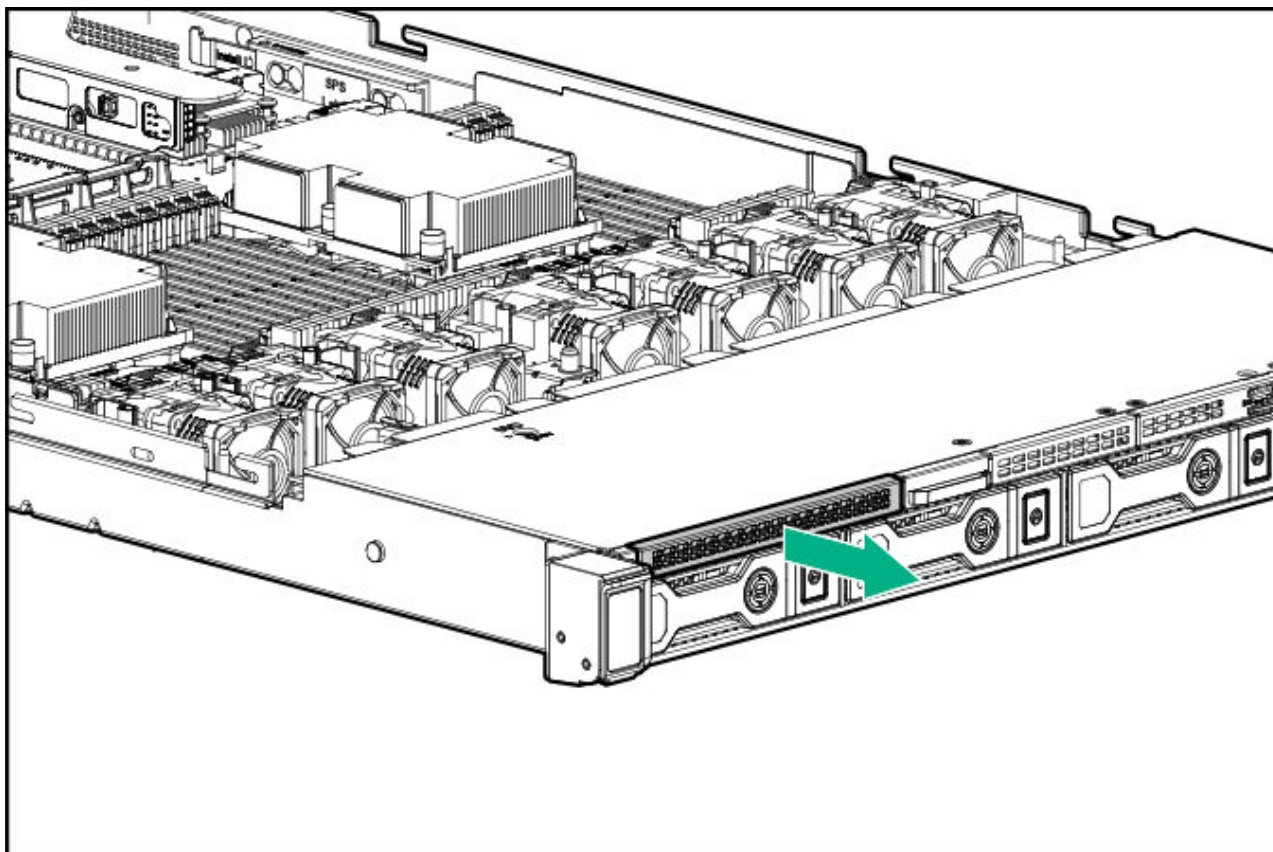

7. Install the optical drive.

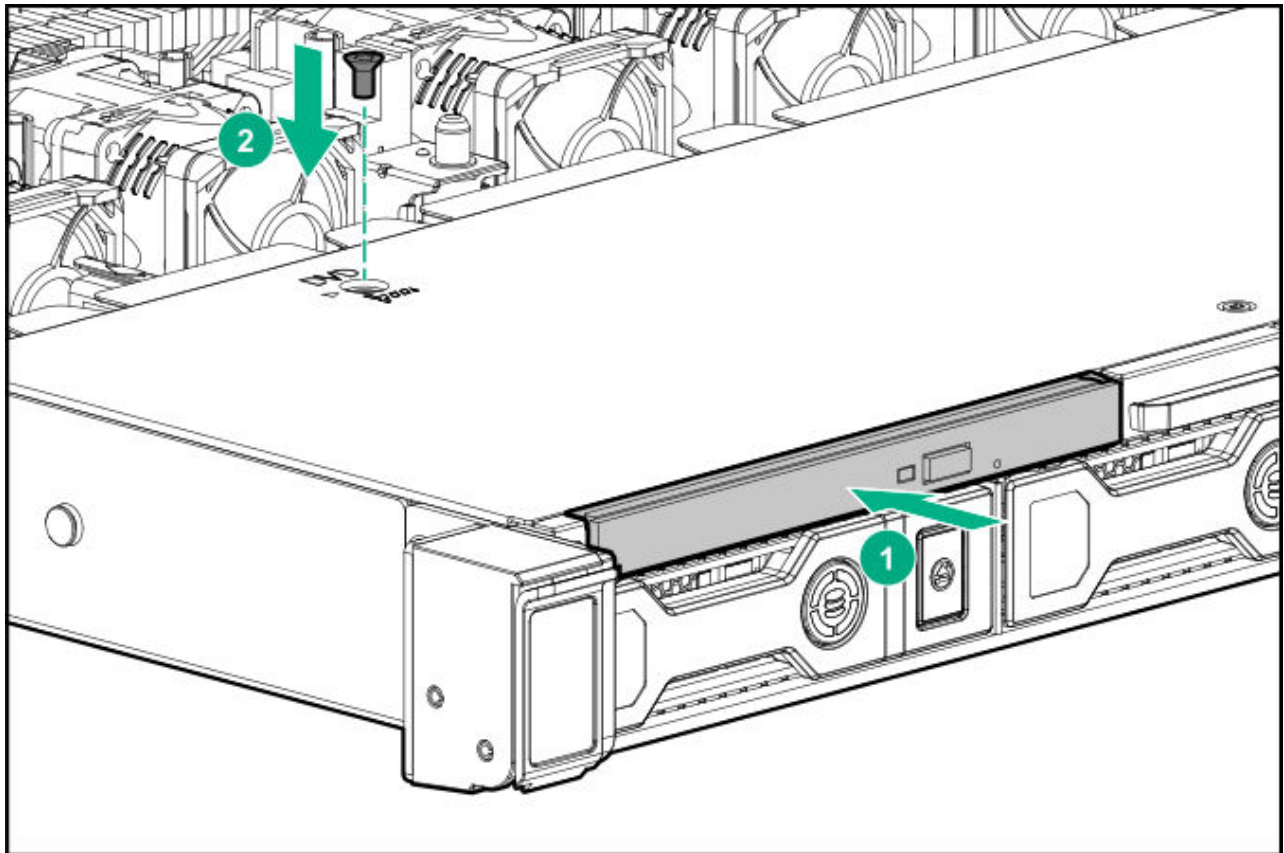

8. Observe the following:



**NOTE:**

The following information describes the standard cable routing for this component. For more information on optional cable routing, see the HPE ProLiant DL360 Gen10 Server cabling matrix on the Hewlett Packard Enterprise website (<https://www.hpe.com/info/CablingMatrixGen10>).

9. Connect the optical drive cable to the optical drive backplane and to the SATA optical/storage drive connector.

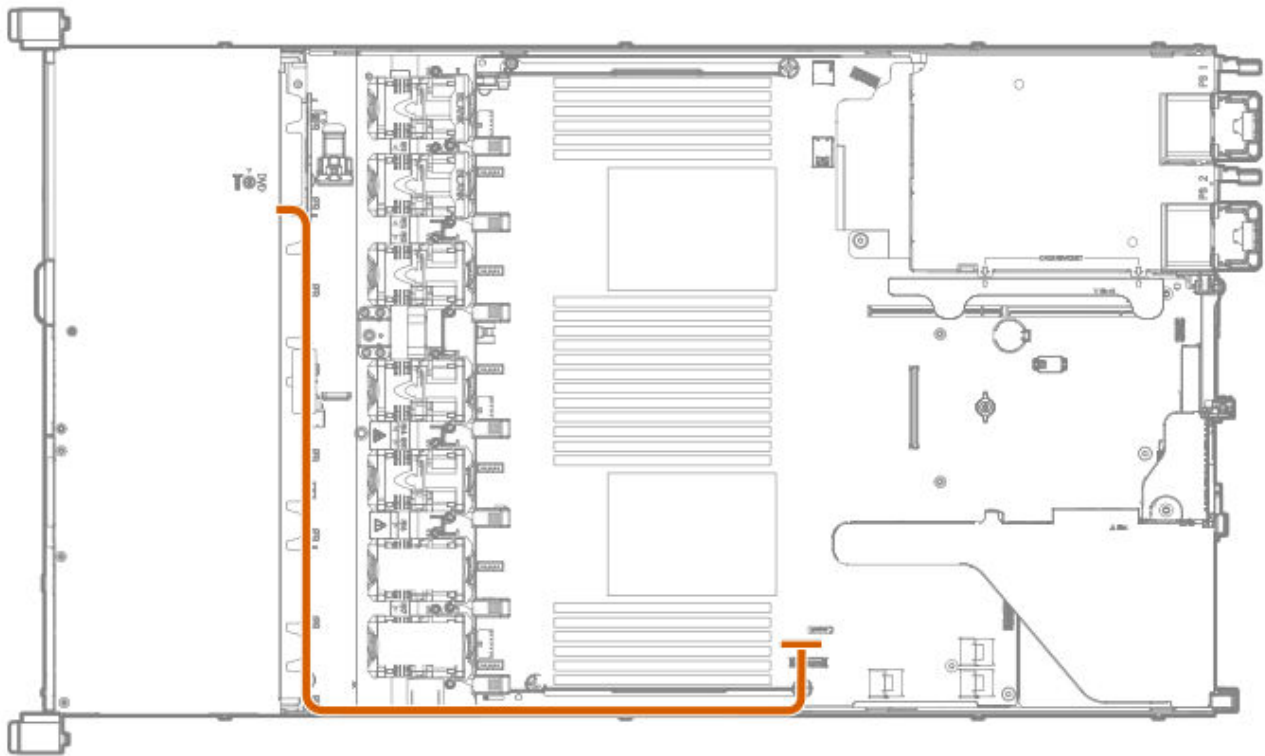

- .0. Install the access panel ([Install the access panel](#)).
- .1. Install the server in the rack.
- .2. Connect each power cord to the server.
- .3. Connect each power cord to the power source.
- .4. Power up the server ([Power up the server](#)).

## Installing the rear drive riser cage option

### Prerequisites

Before installing this option, be sure you have the following:

- The components included with the hardware option kit
- T-10 and T-15 Torx screwdriver
- 1 SFF drive, 2 uFF M.2 drives, or blanks

## About this task

The rear drive riser cage option supports low-profile PCI riser options in slot 2.

## Procedure

1. Power down the server.
2. Remove all power:
  - a. Disconnect each power cord from the power source.
  - b. Disconnect each power cord from the server.
3. Do one of the following:
  - a. Extend the server from the rack.
  - b. Remove the server from the rack.
4. Remove the access panel.
5. Remove the primary PCI riser cage.
6. If installed, remove any expansion boards installed in the riser board.

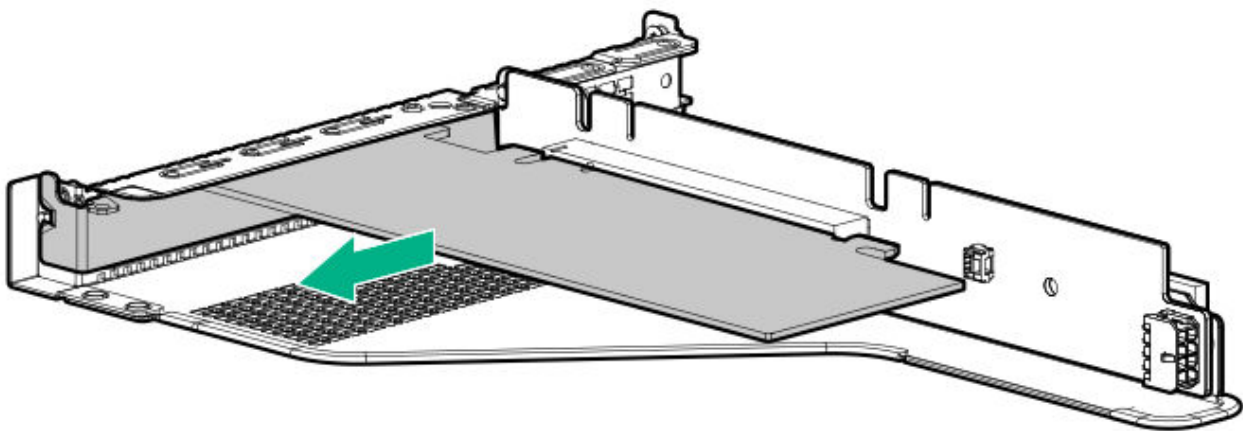

7. Remove the riser board. Set aside for later use.

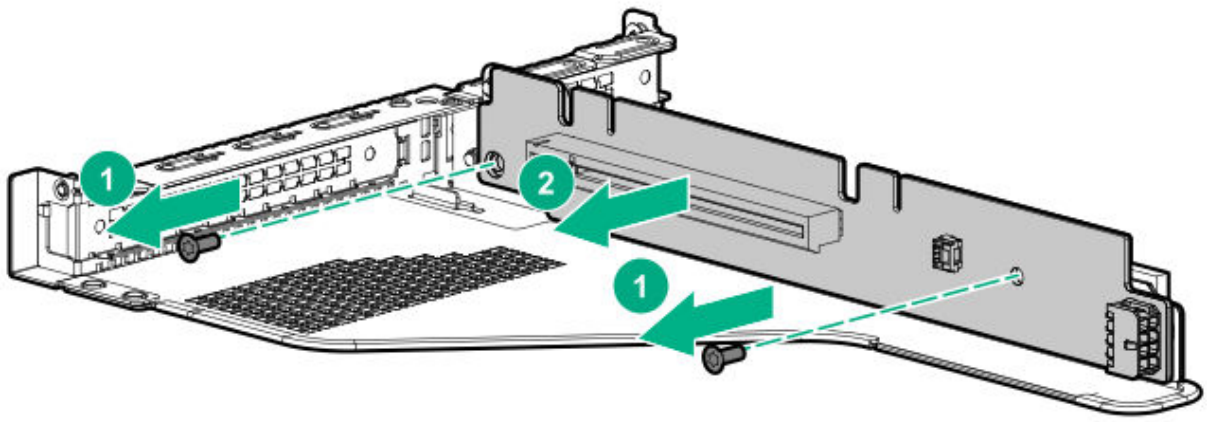

8. If installed, remove the slot 2 bracket from the primary riser cage.

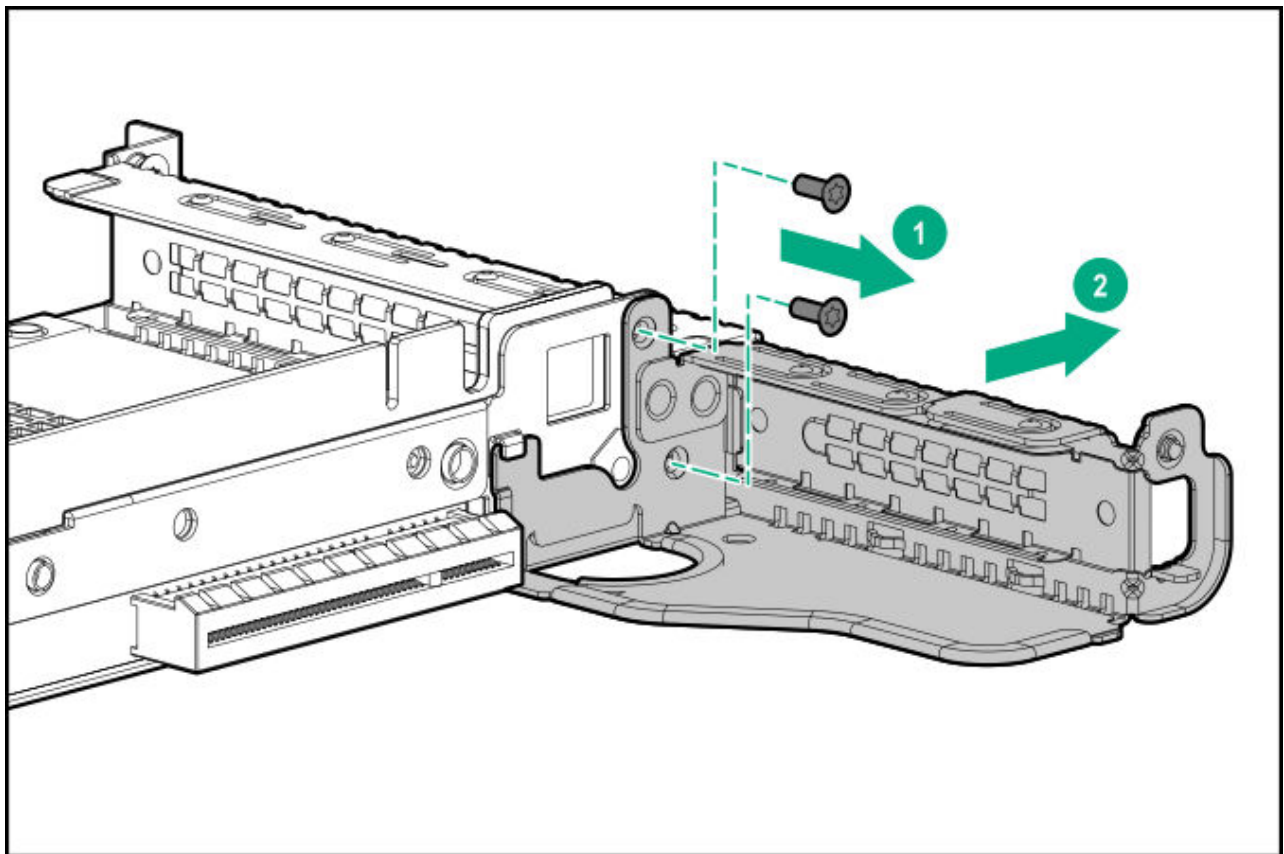

9. If needed, install the riser board removed in step 7 on the rear drive riser cage bracket.

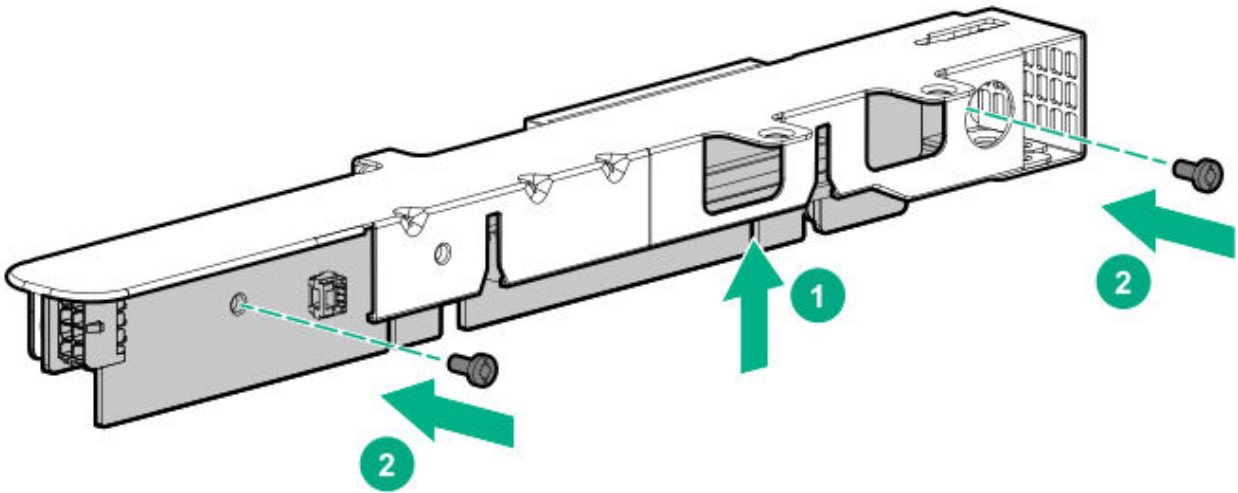

.0. Install the drive cage on the riser cage.

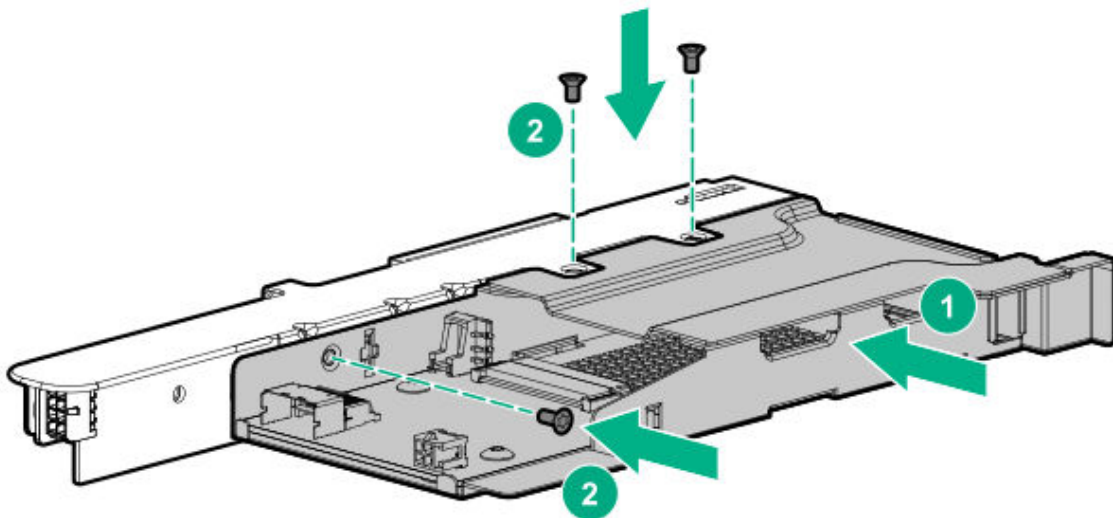

.1. If needed, install the riser cage bracket on the rear drive riser cage.

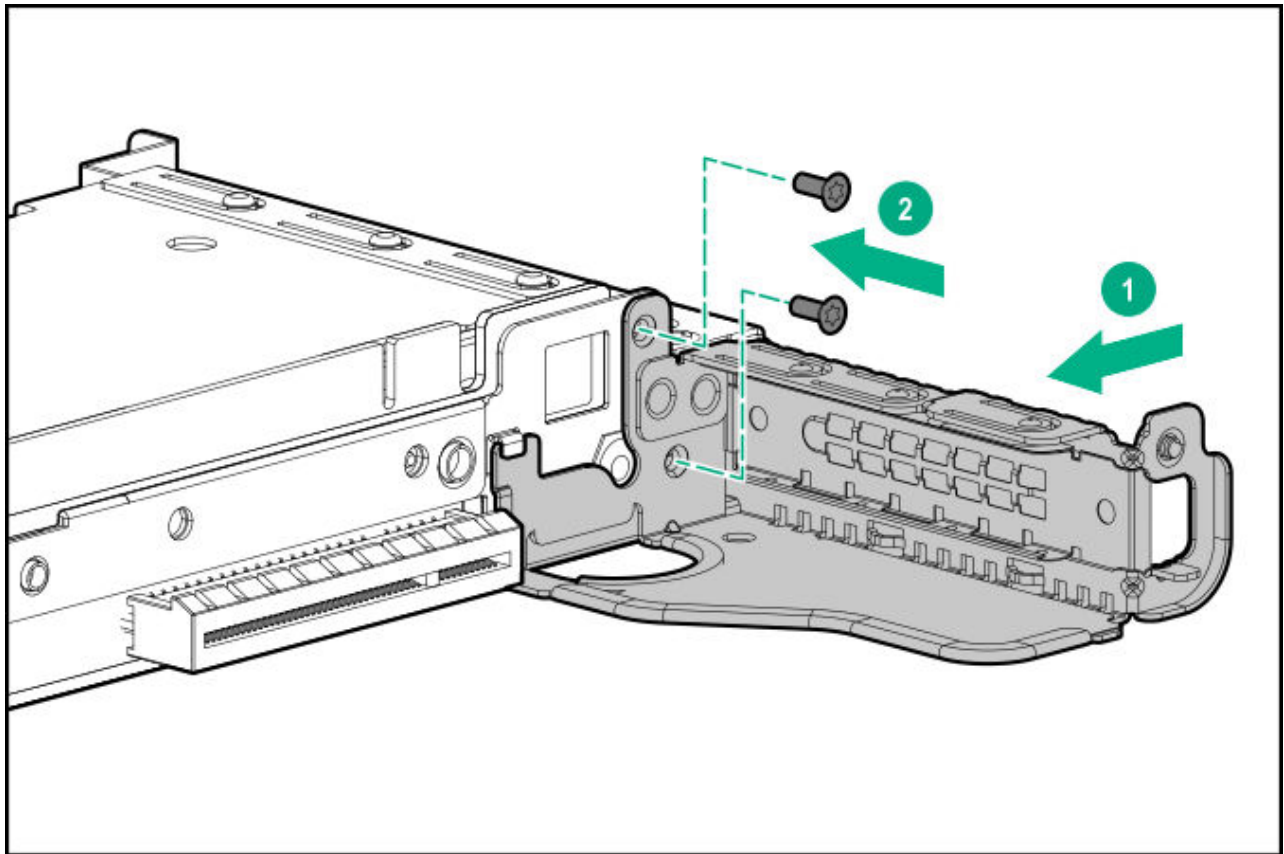

- .2. If needed, install an expansion board.
- .3. Install the rear drive riser cage in the primary riser cage position.

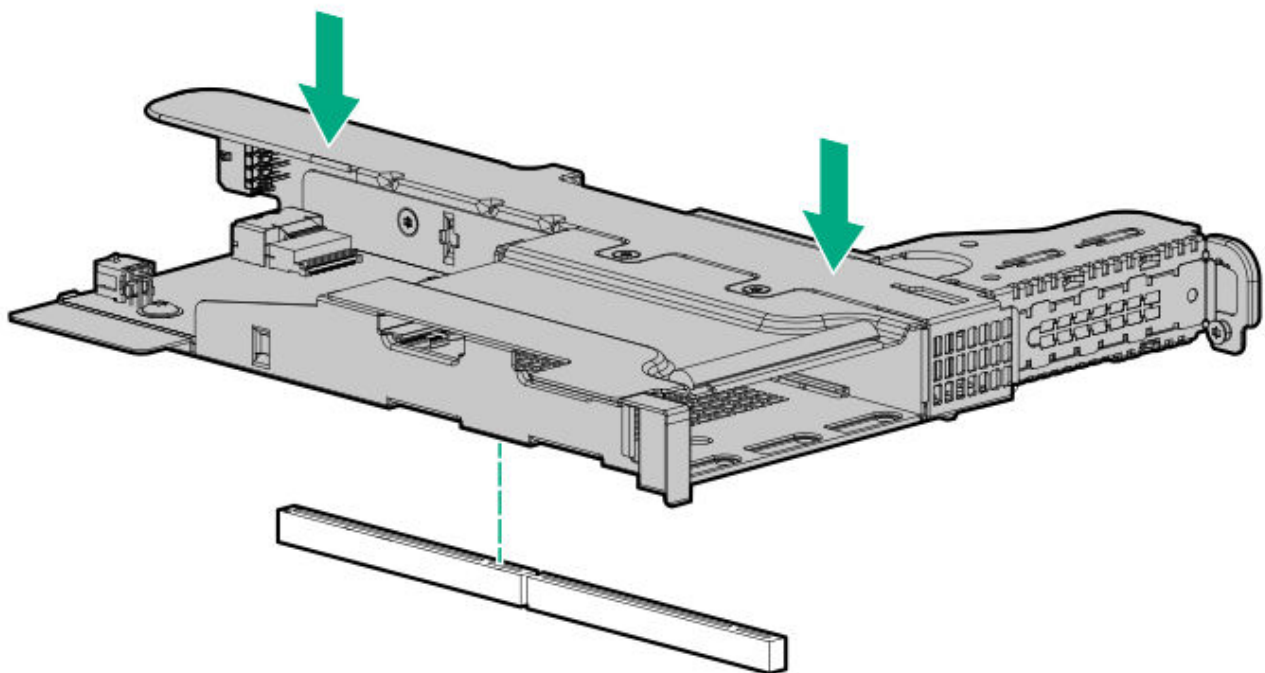

- .4. Route and connect the data and power cables.

Hewlett Packard Enterprise recommends using embedded SATA solutions when connecting the cable. Other options exist. For more information, see the HPE DL360 Gen10 Server cabling matrix on the Hewlett Packard Enterprise website (<https://www.hpe.com/info/CablingMatrixGen10>).

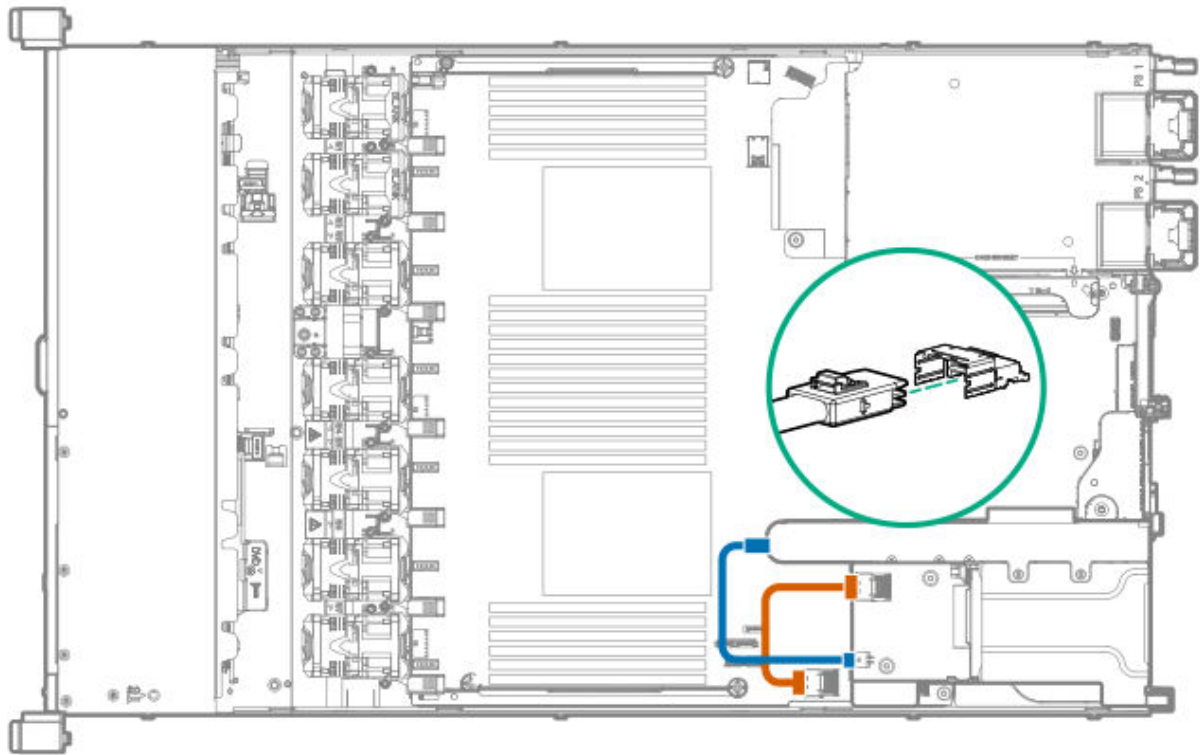

- .5. Install drives or blanks.
- .6. Install the access panel.
- .7. Install the server in the rack.
- .8. Power up the server.
- .9. Connect each power cord to the server.
- .10. Connect each power cord to the power source.

## Primary PCI riser cage options

The primary PCI riser cage supports the following:

- Slot 1: Full-height, 3/4-length expansion boards (up to 9.5")
- Slot 2:
  - Half-length, half-height expansion boards
  - 3/4-length expansion boards when either a low-profile type -a controller or no controller is installed.

## Subtopics

**[Installing an optional primary PCI riser board](#)**

**[Installing the SATA M.2 2280 riser option](#)**

**[Installing an expansion board in the primary riser cage](#)**

**[Installing an accelerator or GPU in the primary riser cage](#)**

# Installing an optional primary PCI riser board

## Prerequisites

Before installing this option, be sure you have the following:

- The components included with the hardware option kit
- T-15 Torx screwdriver

## Procedure

1. Back up all server data.
2. Power down the server ([Power down the server](#)).
3. Remove all power:
  - a. Disconnect each power cord from the power source.
  - b. Disconnect each power cord from the server.
4. Do one of the following:
  - a. Extend the server from the rack ([Extend the server from the rack](#)).
  - b. Remove the server from the rack ([Remove the server from the rack](#)).
5. Remove the access panel ([Remove the access panel](#)).
6. Remove the primary PCI riser cage ([Remove the primary PCI riser cage](#)).
7. If needed, remove any expansion boards installed in the riser cage.

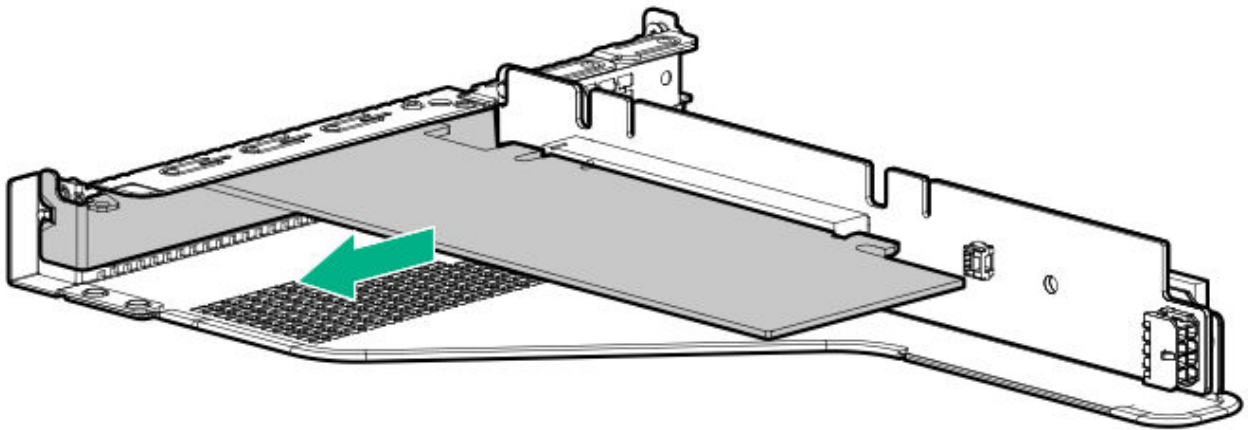

8. Remove the existing riser board from the PCI riser cage.

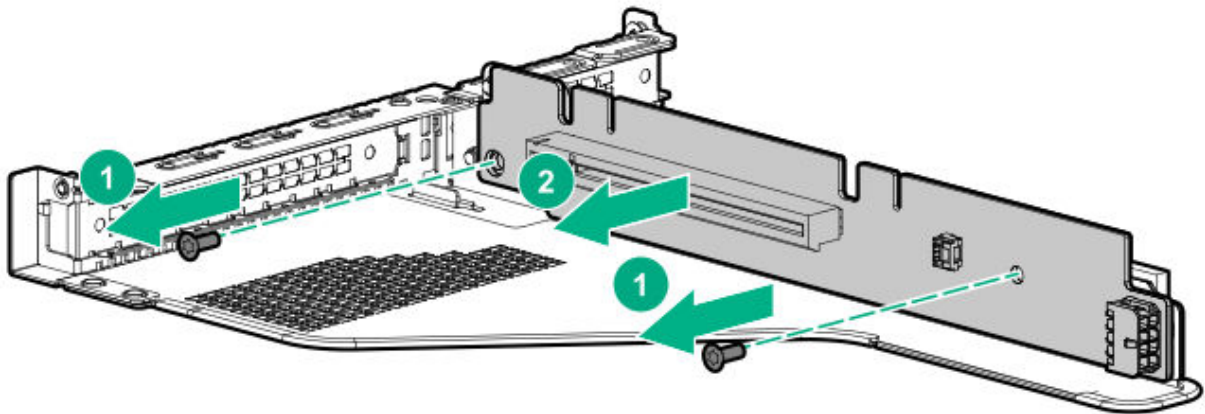

9. Install the optional riser board in the riser cage.

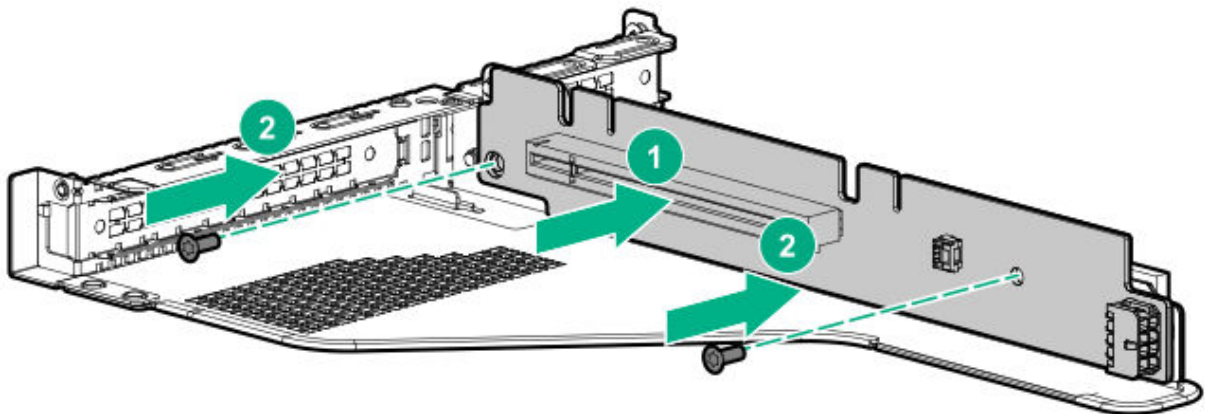

- .0. Install the following, as needed:
  - Expansion boards ([Installing an expansion board in the primary riser cage](#))
  - GPU ([Installing an accelerator or GPU in the primary riser cage](#))
  - Controllers ([Controller options](#))
- .1. Install the riser cage ([Install the primary PCI riser cage](#)).
- .2. Install the access panel ([Install the access panel](#)).
- .3. Install the server in the rack.
- .4. Connect each power cord to the server.
- .5. Connect each power cord to the power source.
- .6. Power up the server ([Power up the server](#)).

## Installing the SATA M.2 2280 riser option

### Prerequisites

Before installing this option, be sure that you have the following:

- The components included with the hardware option kit
- Up to two 2280 form factor M.2 drives
- T-15 Torx screwdriver

### Procedure

1. Power down the server ([Power down the server](#)).
2. Remove all power:
  - a. Disconnect each power cord from the power source.
  - b. Disconnect each power cord from the server.
3. Do one of the following:
  - a. Extend the server from the rack ([Extend the server from the rack](#)).
  - b. Remove the server from the rack ([Remove the server from the rack](#)).
4. Remove the access panel ([Remove the access panel](#)).

5. Remove the primary PCI riser cage ([Remove the primary PCI riser cage](#)).
6. If needed, remove any expansion boards installed in the riser cage.

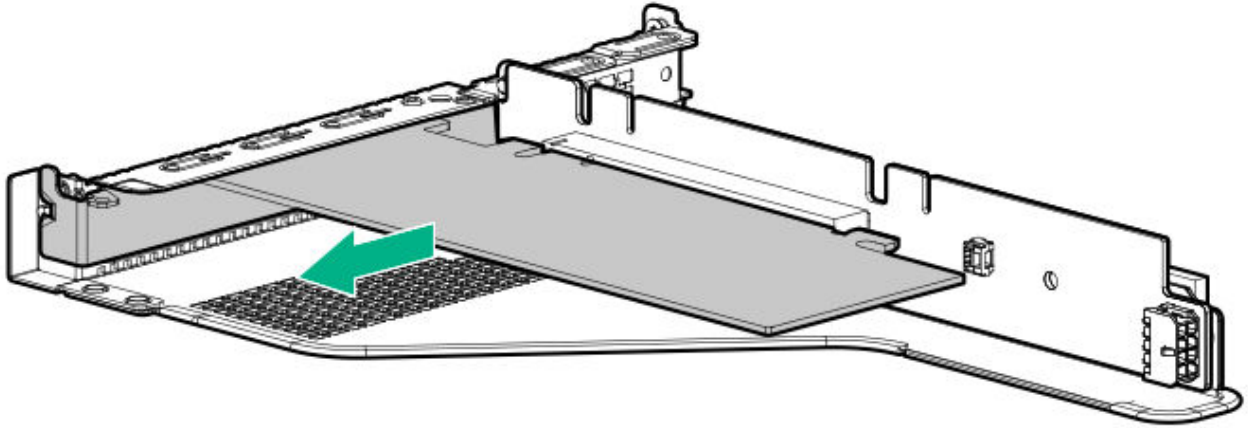

7. Remove the existing riser board from the riser cage.

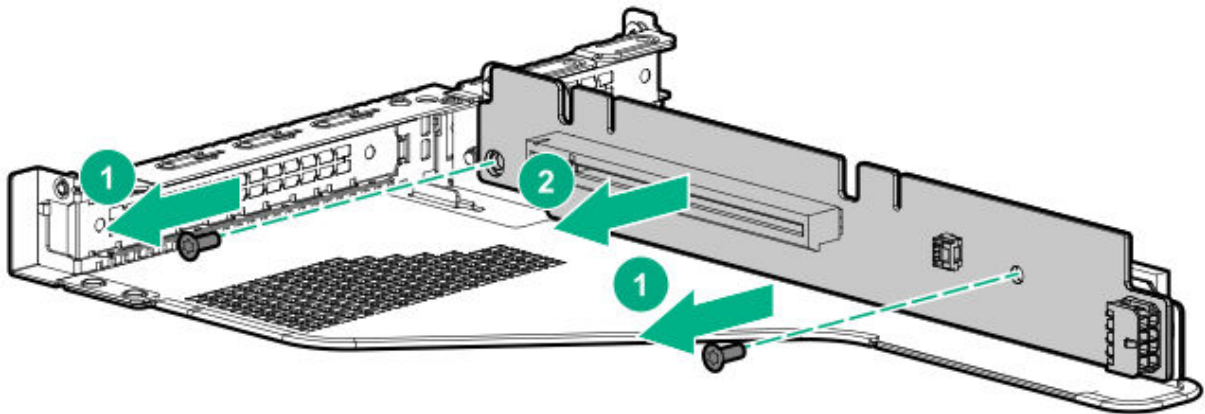

8. Install the M.2 riser board.

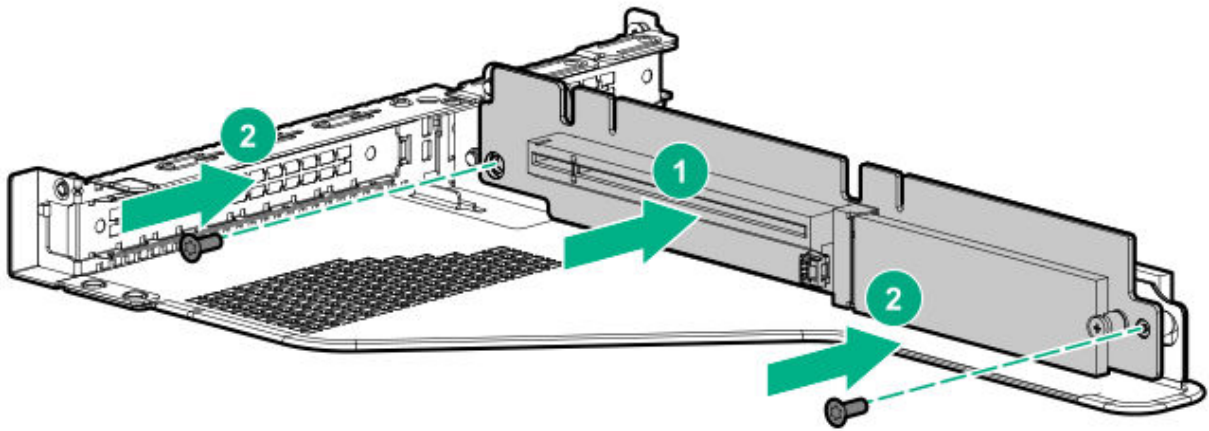

9. Remove the screw securing the standoff on the riser.

10. Install the M.2 drives.

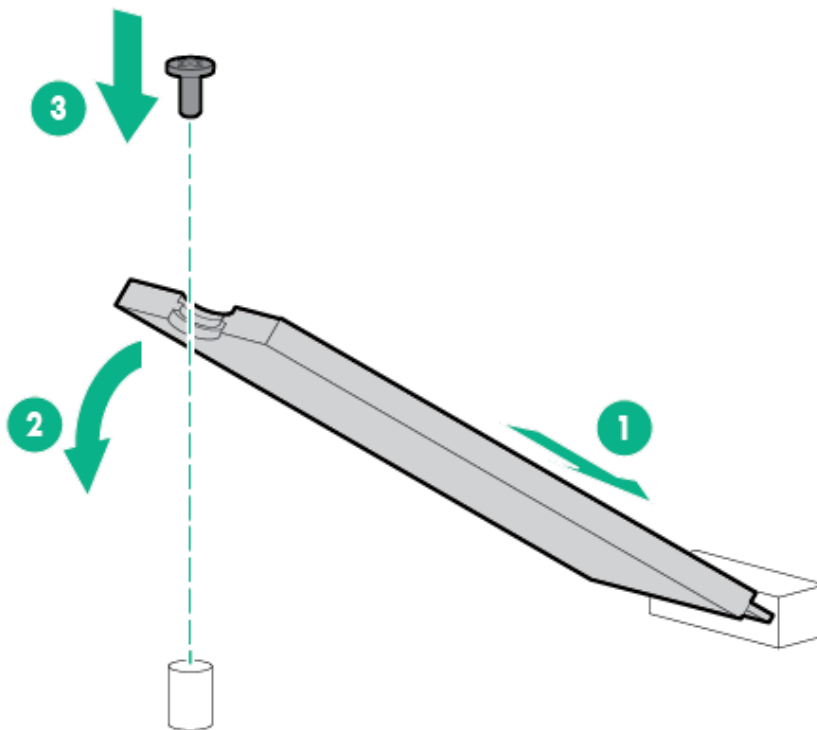

1. Install the following, as needed:

- Expansion boards ([Installing an expansion board in the primary riser cage](#))
- Controllers ([Controller options](#))

2. Install the primary PCI riser cage ([Install the primary PCI riser cage](#)).

- .3. Install the access panel ([Install the access panel](#)).
- .4. Install the server in the rack.

## Installing an expansion board in the primary riser cage

### Prerequisites

Before installing this option, be sure you have the following:

- The components included with the hardware option kit.
- T-10 Torx screwdriver.

### About this task

Use these instructions to install expansion boards such as Smart I/O cards (such as DSC-25 2-port SFP28 card), solid state NVMe/PCIe Add-In-Cards, HBAs, CNAs, InfiniBand adapters, and accelerators.

### Procedure

1. Observe the following alerts:



**WARNING:** To reduce the risk of personal injury from hot surfaces, allow the drives and the internal system components to cool before touching them.



**CAUTION:** To prevent damage to electrical components, properly ground the server before beginning any installation procedure. Improper grounding can cause electrostatic discharge.

2. Back up all server data.
3. [Power down the server](#).
4. Remove all power:
  - a. Disconnect each power cord from the power source.
  - b. Disconnect each power cord from the server.
5. Do one of the following:
  - a. [Extend the server from the rack](#).
  - b. [Remove the server from the rack](#).

6. Remove the access panel.
7. Remove the primary PCI riser cage.
8. Remove the expansion slot blank.

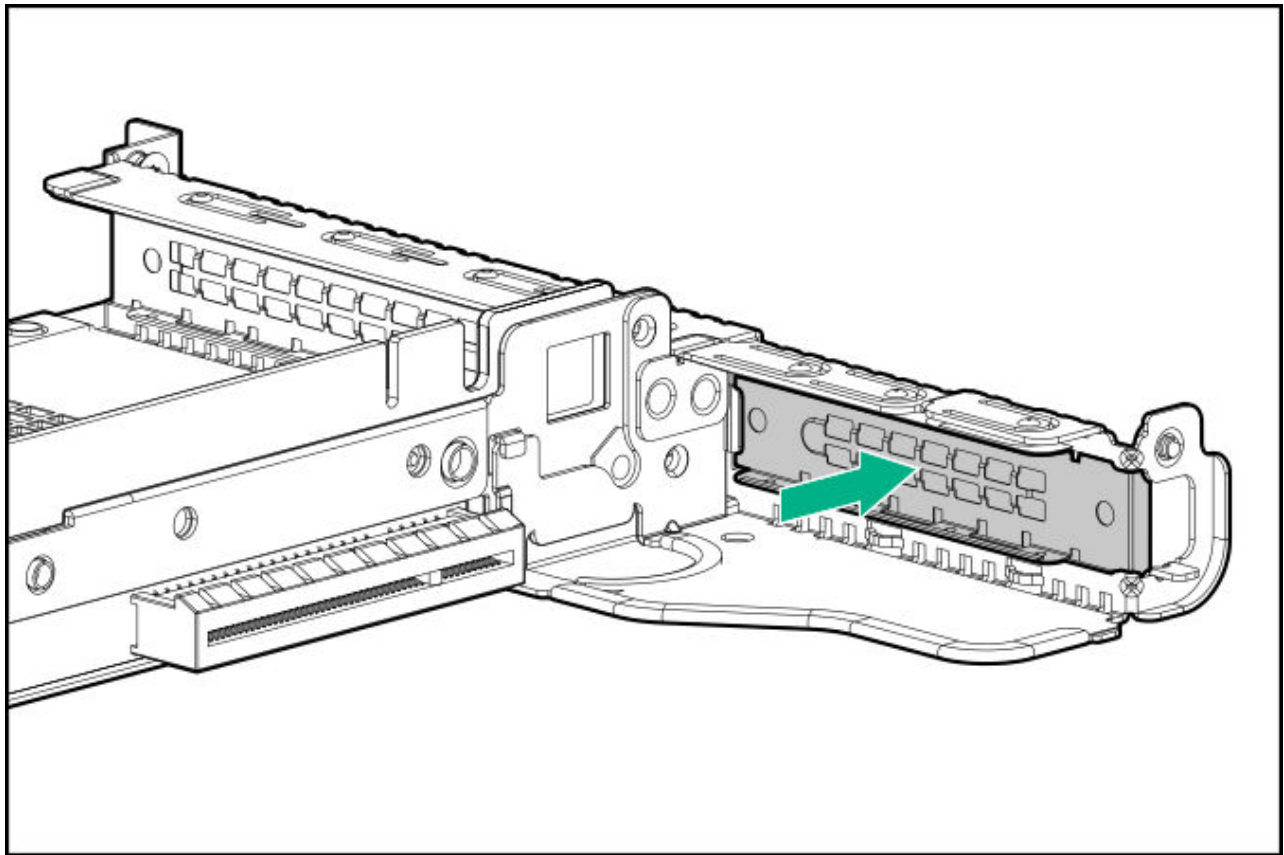

9. Use a T-10 Torx screwdriver to Install the expansion board.

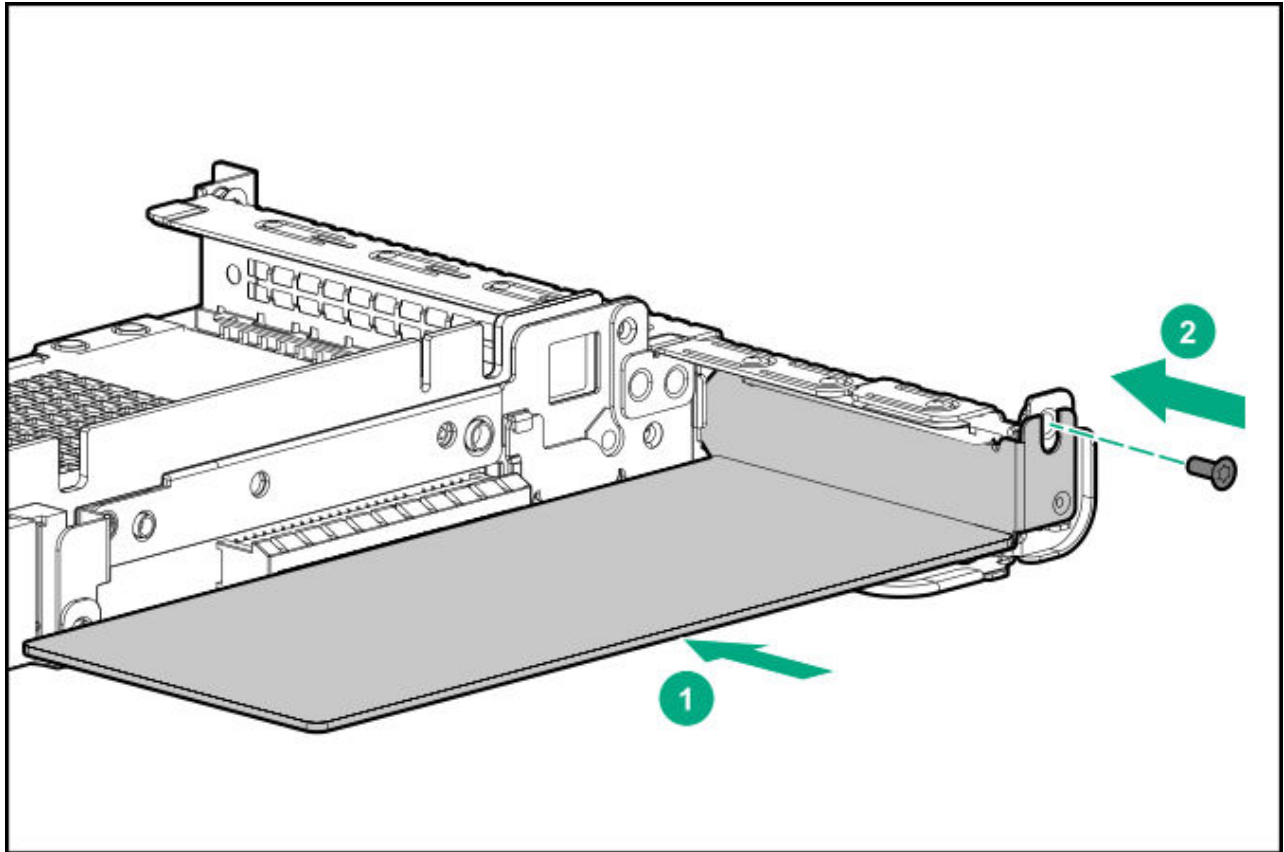

- .0. Connect any required internal or external cables to the expansion board.
- .1. Install the primary PCI riser cage.
- .2. Install the access panel.
- .3. Install the server in the rack.
- .4. Connect each power cord to the server.
- .5. Connect each power cord to the power source.
- .6. Power up the server.

## Installing an accelerator or GPU in the primary riser cage

### Prerequisites

This option requires the standard primary PCI riser cage.

Before installing this option, be sure that the power supplies support the installation of this option. For more information, see the [Hewlett Packard Enterprise Configurator website](#).

In addition, be sure that you have the following items:

- The components included with the hardware option kit
- HPE DL360 Gen10 CPU1 Cable Kit (If installing a high-powered GPU kit)

### About this task

Use these instructions to install accelerator options, including GPUs, in the server.

### Procedure

1. Observe the following alerts:



**WARNING:** To reduce the risk of personal injury from hot surfaces, allow the drives and the internal system components to cool before touching them.



**CAUTION:** To prevent damage to electrical components, properly ground the server before beginning any installation procedure. Improper grounding can cause electrostatic discharge.

2. Back up all server data.
3. Power down the server ([Power down the server](#)).
4. Remove all power:
  - a. Disconnect each power cord from the power source.
  - b. Disconnect each power cord from the server.
5. Do one of the following:
  - a. Extend the server from the rack ([Extend the server from the rack](#)).
  - b. Remove the server from the rack ([Remove the server from the rack](#)).
6. Remove the access panel ([Remove the access panel](#)).
7. Remove the primary PCI riser cage ([Remove the primary PCI riser cage](#)).
8. Install the card in the x16 slot in the primary PCI riser cage position.
9. If installing a GPU requiring greater than 75 W, connect the power cable to the primary riser power connector.

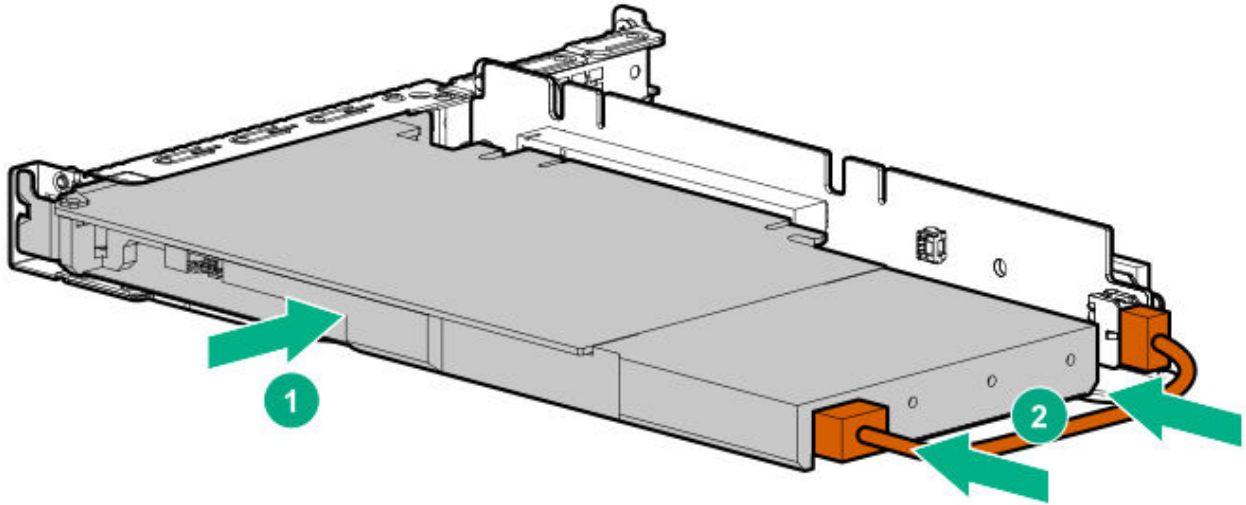

.0. If the card requires rear support, install the GPU support bracket.

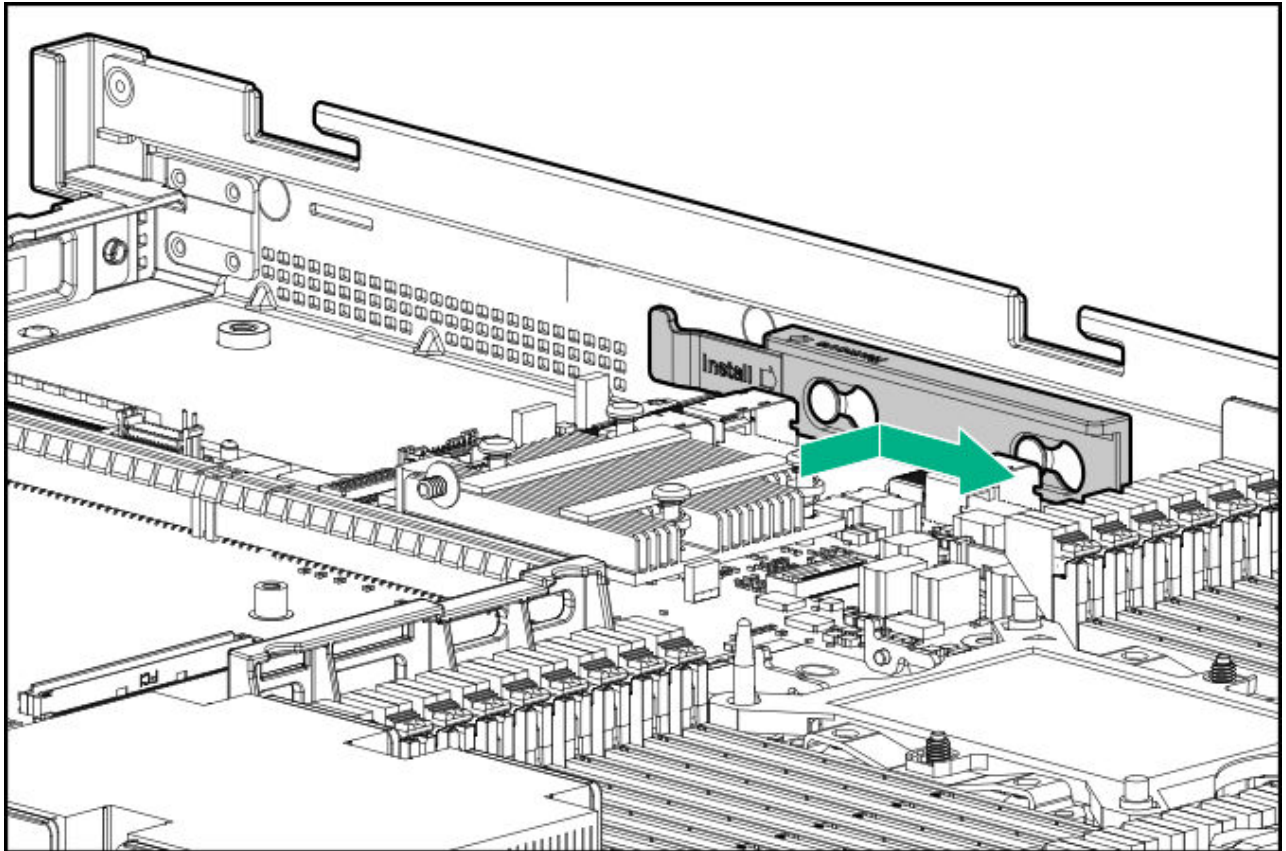

.1. Install the riser cage (Install the primary PCI riser cage).

.2. Install the access panel (Install the access panel).

- .3. Install the server in the rack.
- .4. Connect each power cord to the server.
- .5. Connect each power cord to the power source.
- .6. Power up the server ([Power up the server](#)).

## Secondary PCI riser options

### Subtopics

[Installing a secondary full-height PCI riser cage option](#)

[Installing a secondary low-profile PCIe slot riser cage option](#)

[Installing an expansion board in the secondary riser cage](#)

[Installing an accelerator or GPU in the secondary riser cage](#)

## Installing a secondary full-height PCI riser cage option

### Prerequisites

This option requires a dual processor configuration.

Before installing this option, be sure you have the following:

- The components included with the hardware option kit
- Any expansion boards or controllers you plan to install
- T-10 Torx screwdriver
- T-15 Torx screwdriver

### About this task

When installed, this riser cage supports full-height, 3/4-length expansion boards up to 9.5". PCIe3 slot 2 is no longer available.

### Procedure

1. Power down the server ([Power down the server](#)).
2. Remove all power:
  - a. Disconnect each power cord from the power source.

- b. Disconnect each power cord from the server.
3. Do one of the following:
  - a. Extend the server from the rack (Extend the server from the rack).
  - b. Remove the server from the rack (Remove the server from the rack).
4. Remove the access panel (Remove the access panel).
5. Remove the primary PCI riser cage (Remove the primary PCI riser cage).
6. Use a T-10 Torx screwdriver to remove the slot 2 bracket from the primary riser cage.

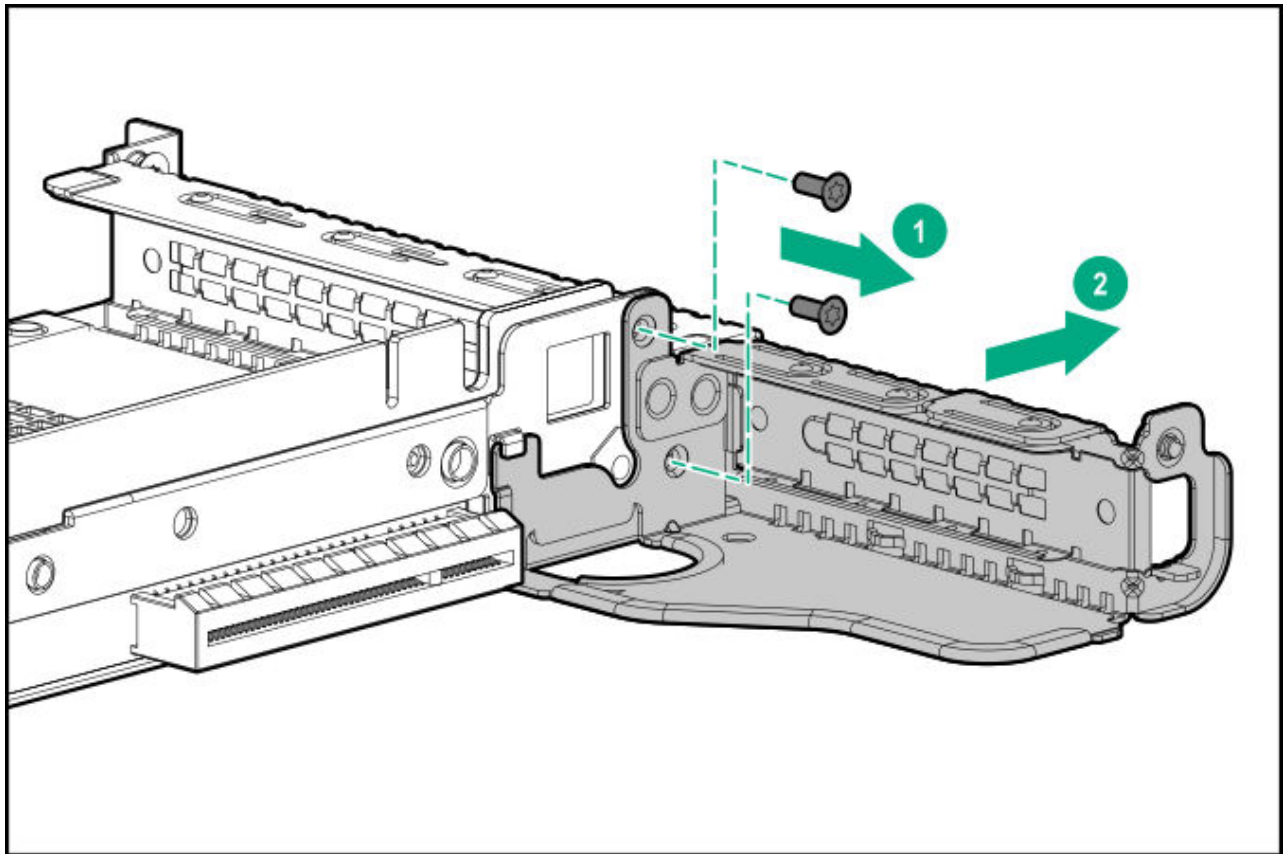

7. If installed, remove the low-profile riser cage.

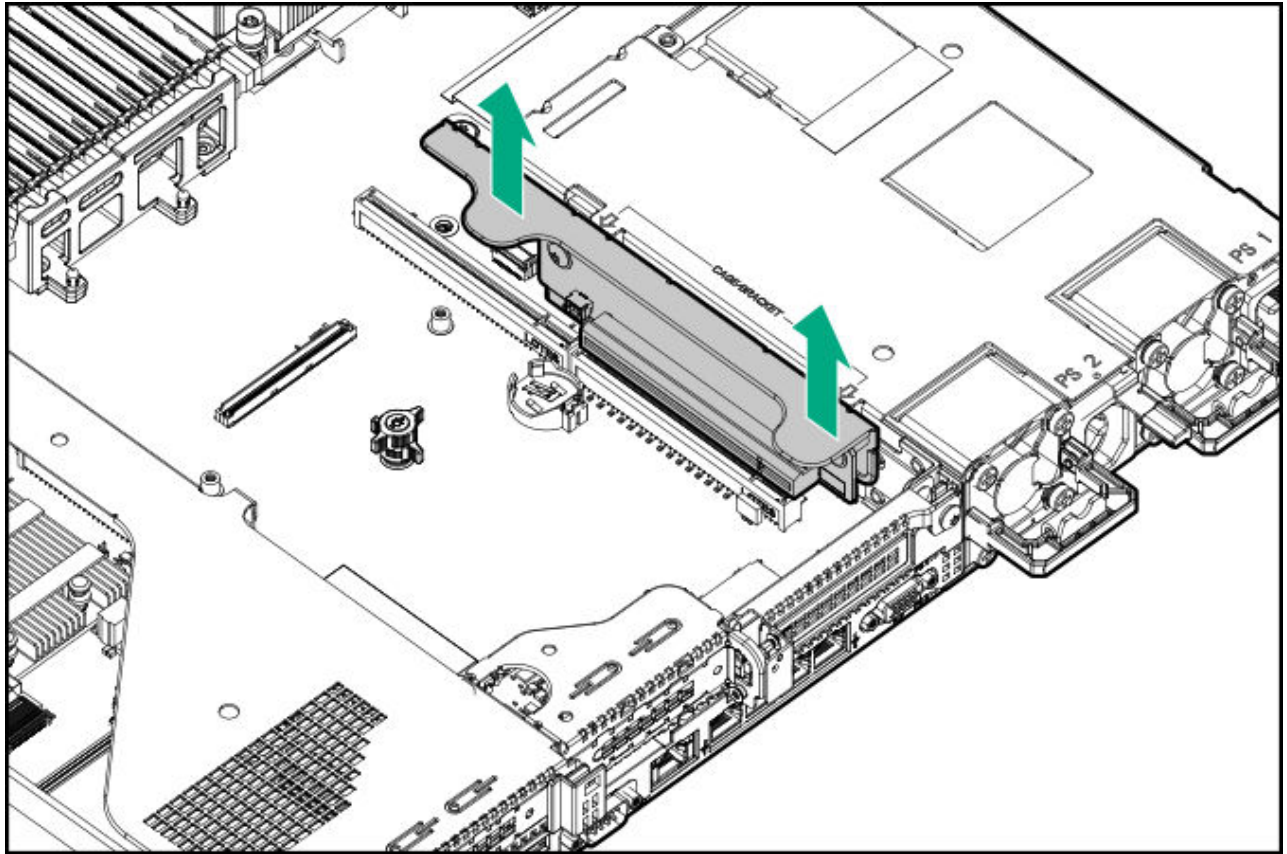

8. Lift and remove the secondary riser cage latch.

Use a T-15 Torx screwdriver to remove the riser cage screw.

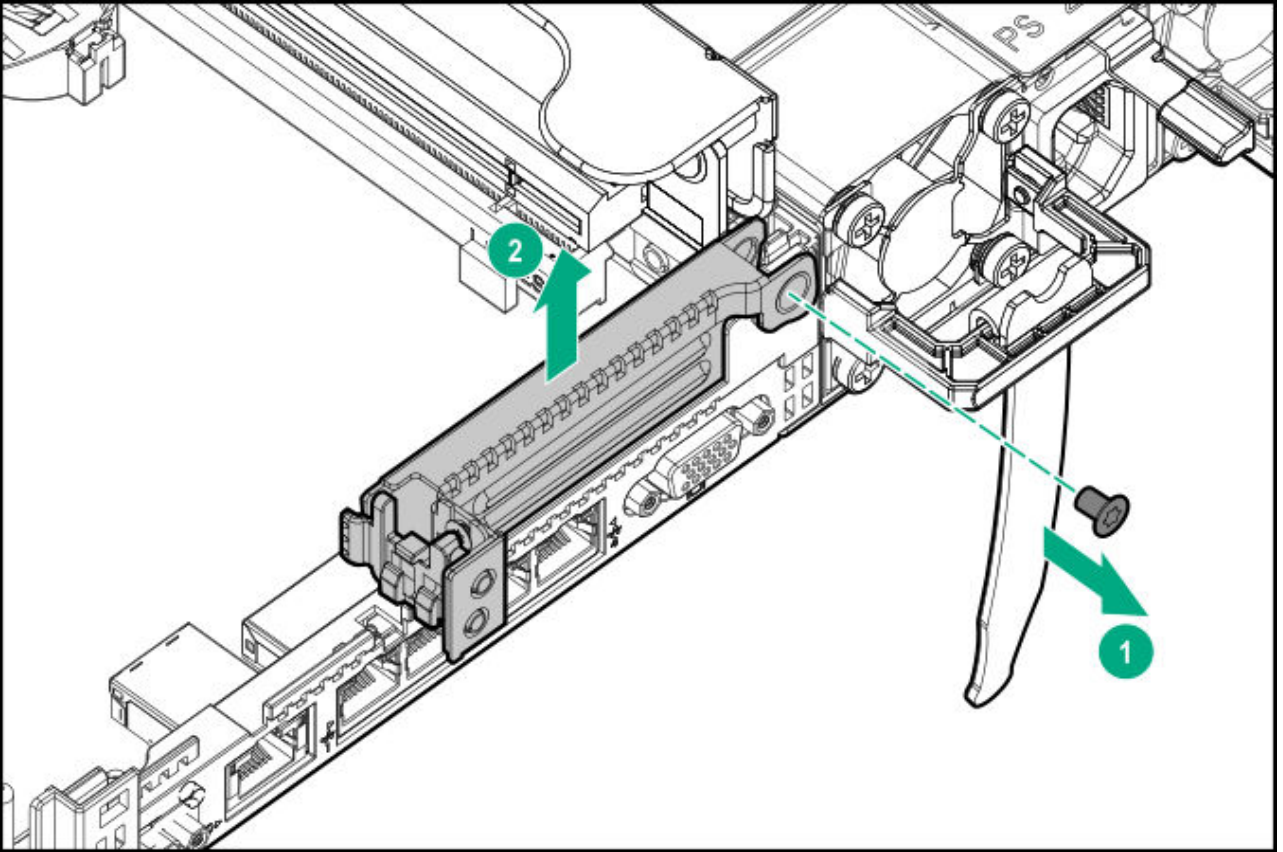

9. Install the full height PCIe x16 riser cage latch.

Use a T-15 Torx screwdriver to remove the riser cage screw.

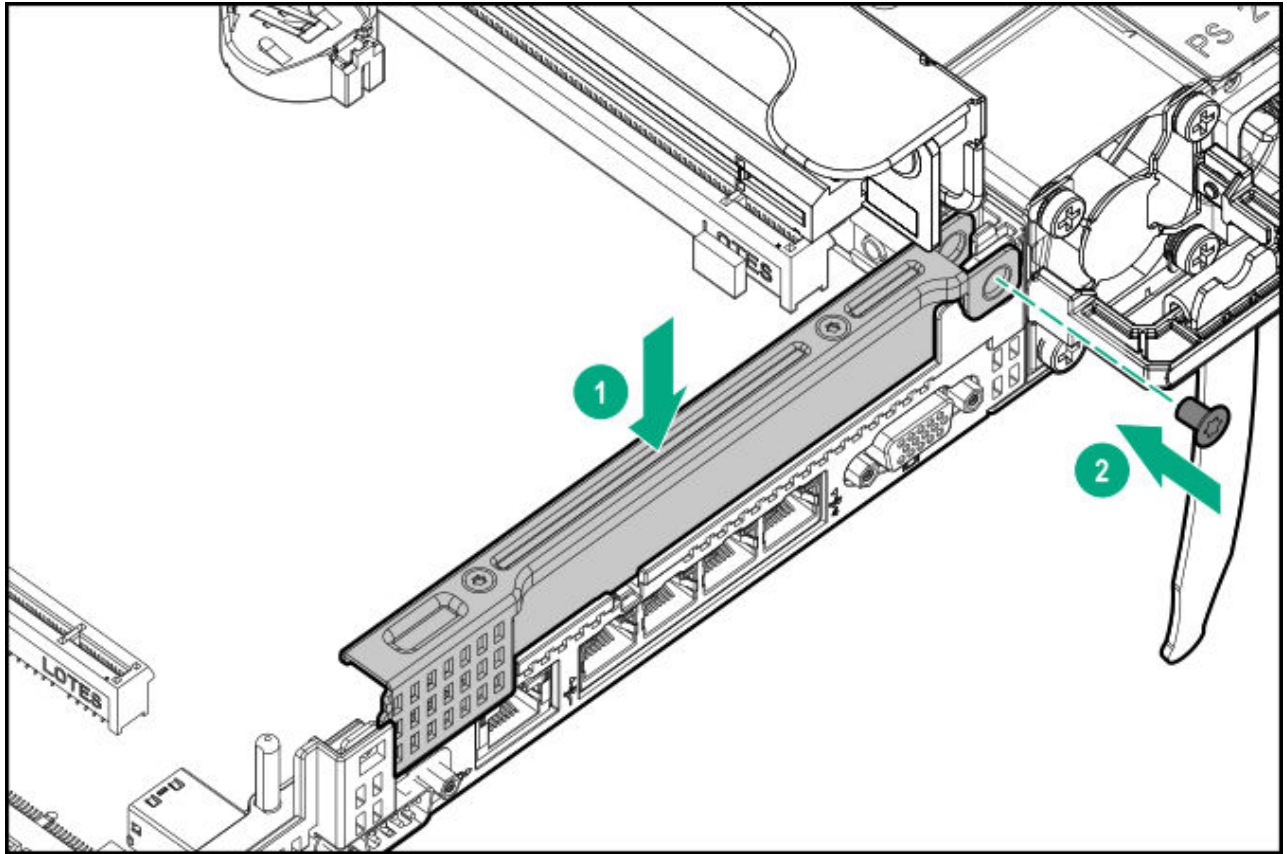

.0. Install the riser cage.

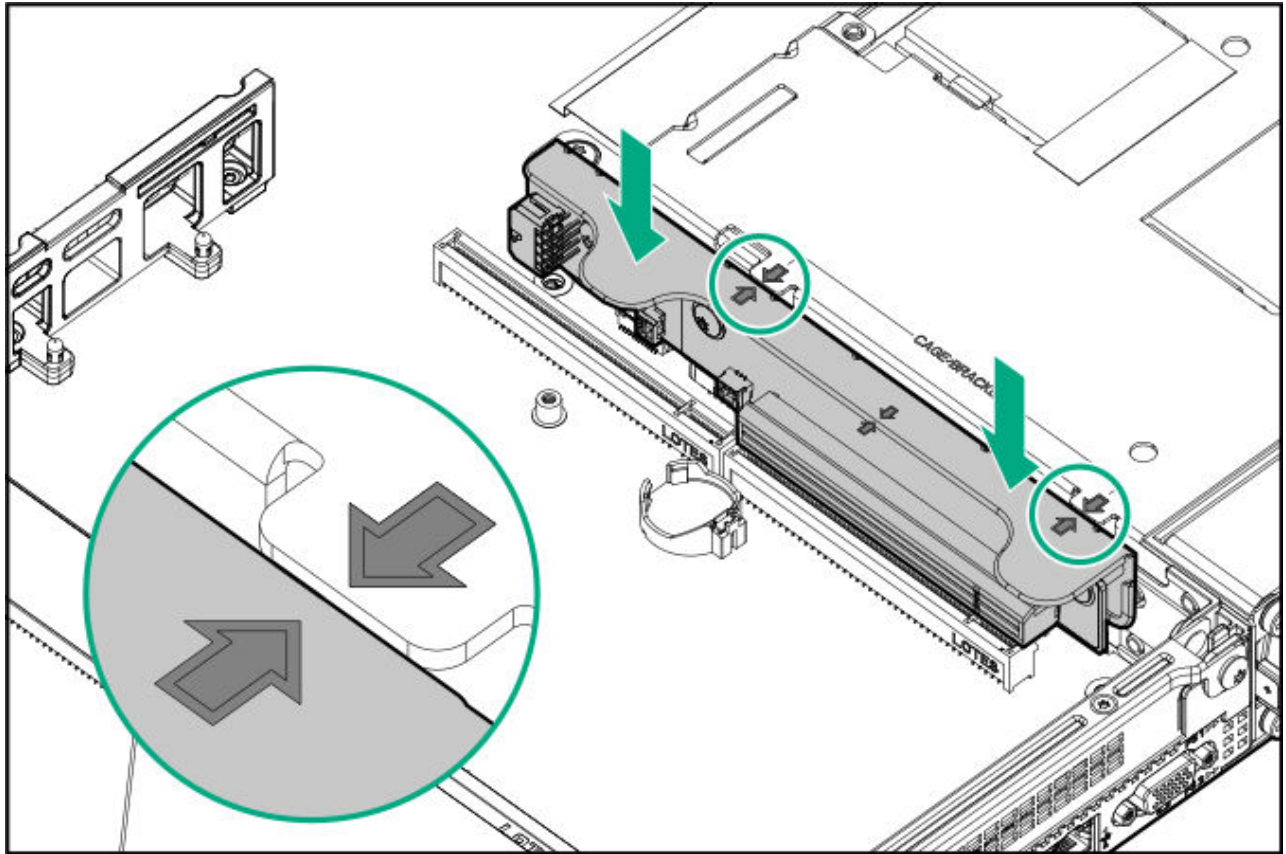

- .1. Install one of the following, as needed:
  - Expansion boards ([Installing an expansion board in the secondary riser cage](#))
  - GPU ([Installing an accelerator or GPU in the secondary riser cage](#))
  - Controllers ([Controller options](#))
- .2. Install the access panel ([Install the access panel](#)).
- .3. Install the server in the rack.
- .4. Connect each power cord to the server.
- .5. Connect each power cord to the power source.
- .6. Power up the server ([Power up the server](#)).

# Installing a secondary low-profile PCIe slot riser cage option

## Prerequisites

This option requires a dual processor configuration.

Before installing this option, be sure that you have the following:

The components included with the hardware option kit

## About this task

When installed, this riser cage provides an additional low profile slot and supports half-length/half-height expansion boards.

## Procedure

1. Observe the following alerts:



**WARNING:** To reduce the risk of personal injury from hot surfaces, allow the drives and the internal system components to cool before touching them.



**CAUTION:** To prevent damage to electrical components, properly ground the server before beginning any installation procedure. Improper grounding can cause electrostatic discharge.

2. Back up all server data.
3. Power down the server ([Power down the server](#)).
4. Remove all power:
  - a. Disconnect each power cord from the power source.
  - b. Disconnect each power cord from the server.
5. Do one of the following:
  - a. Extend the server from the rack ([Extend the server from the rack](#)).
  - b. Remove the server from the rack ([Remove the server from the rack](#)).
6. Remove the access panel ([Remove the access panel](#)).
7. Install the secondary low-profile PCIe slot riser cage.

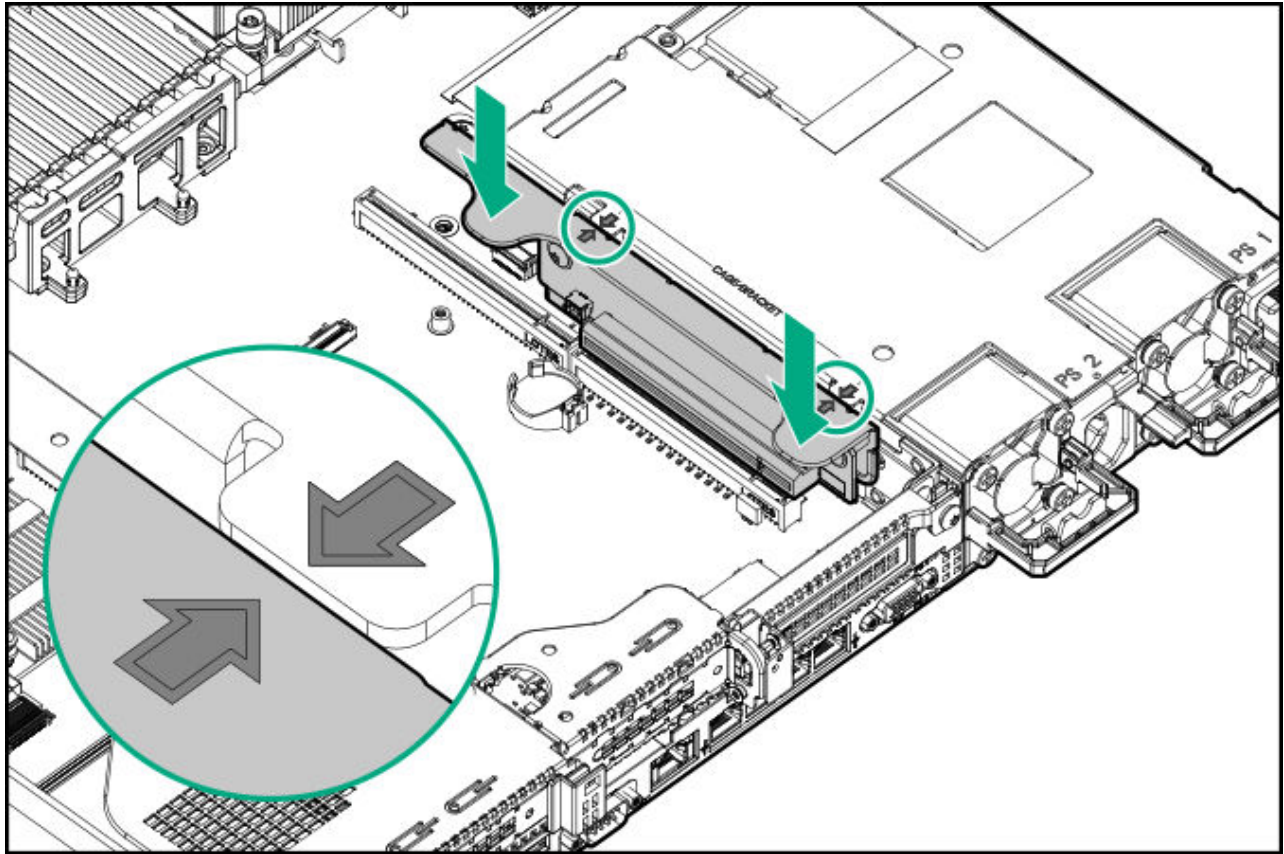

8. Install one of the following, as needed:
  - Expansion boards ([Installing an expansion board in the secondary riser cage](#))
  - Controllers ([Controller options](#))
9. Install the access panel ([Install the access panel](#)).
10. Install the server into the rack ([#GUID-D335199C-041B-4BE2-B1EB-A302EF71D53E](#)).
- 11.1. Connect each power cord to the server.
- 11.2. Connect each power cord to the power source.
- 11.3. Power up the server ([Power up the server](#)).

## Installing an expansion board in the secondary riser cage

### Prerequisites

Before installing this option, be sure that you have the following:

- The components included with the hardware option kit
- T-10 Torx screwdriver

### About this task

Use these instructions to install expansion boards such as Smart I/O cards (such as DSC-25 2-port SFP28 cards), solid state NVMe/PCIe Add-In-Cards, HBAs, CNAs, InfiniBand adapters, and accelerators.

### Procedure

1. Observe the following alerts:



**WARNING:** To reduce the risk of personal injury from hot surfaces, allow the drives and the internal system components to cool before touching them.



**CAUTION:** To prevent damage to electrical components, properly ground the server before beginning any installation procedure. Improper grounding can cause electrostatic discharge.

2. Back up all server data.
3. Power down the server ([Power down the server](#)).
4. Remove all power:
  - a. Disconnect each power cord from the power source.
  - b. Disconnect each power cord from the server.
5. Do one of the following:
  - a. [Extend the server from the rack](#).
  - b. [Remove the server from the rack](#).
6. [Remove the access panel](#).
7. Install a secondary riser cage:
  - Low-profile ([Installing a secondary low-profile PCIe slot riser cage option](#))
  - Full-height ([Installing a secondary full-height PCI riser cage option](#))
8. Remove the expansion slot blank:

A T-10 Torx screwdriver is required to remove the expansion slot blank.

  - Half-length

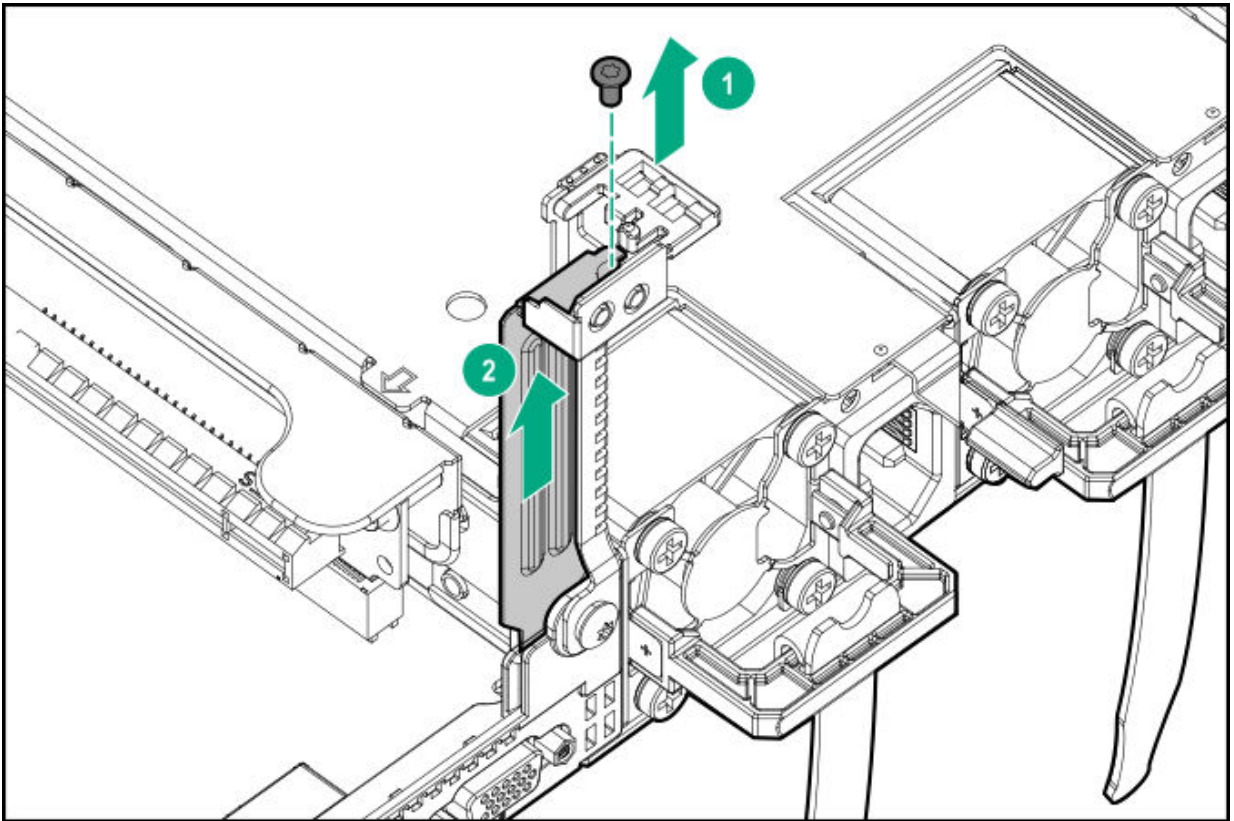
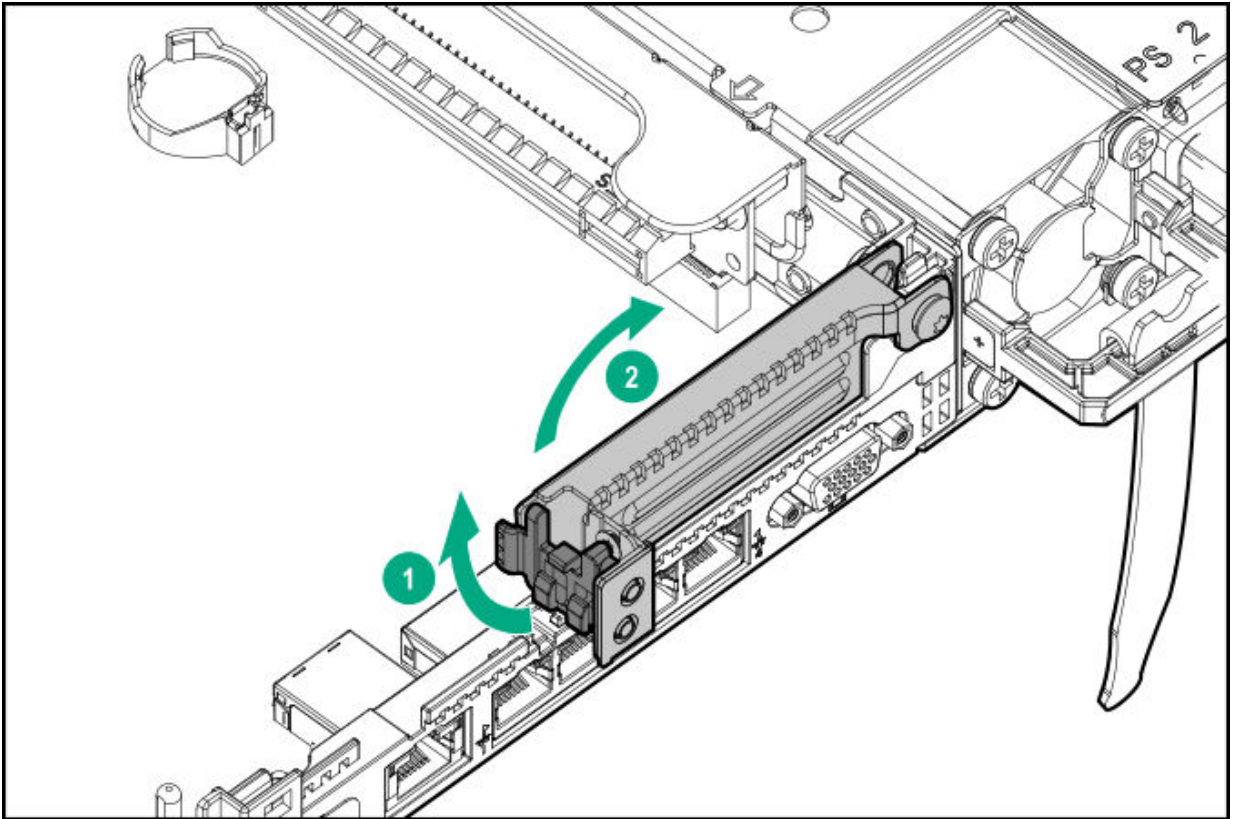

- Full-length

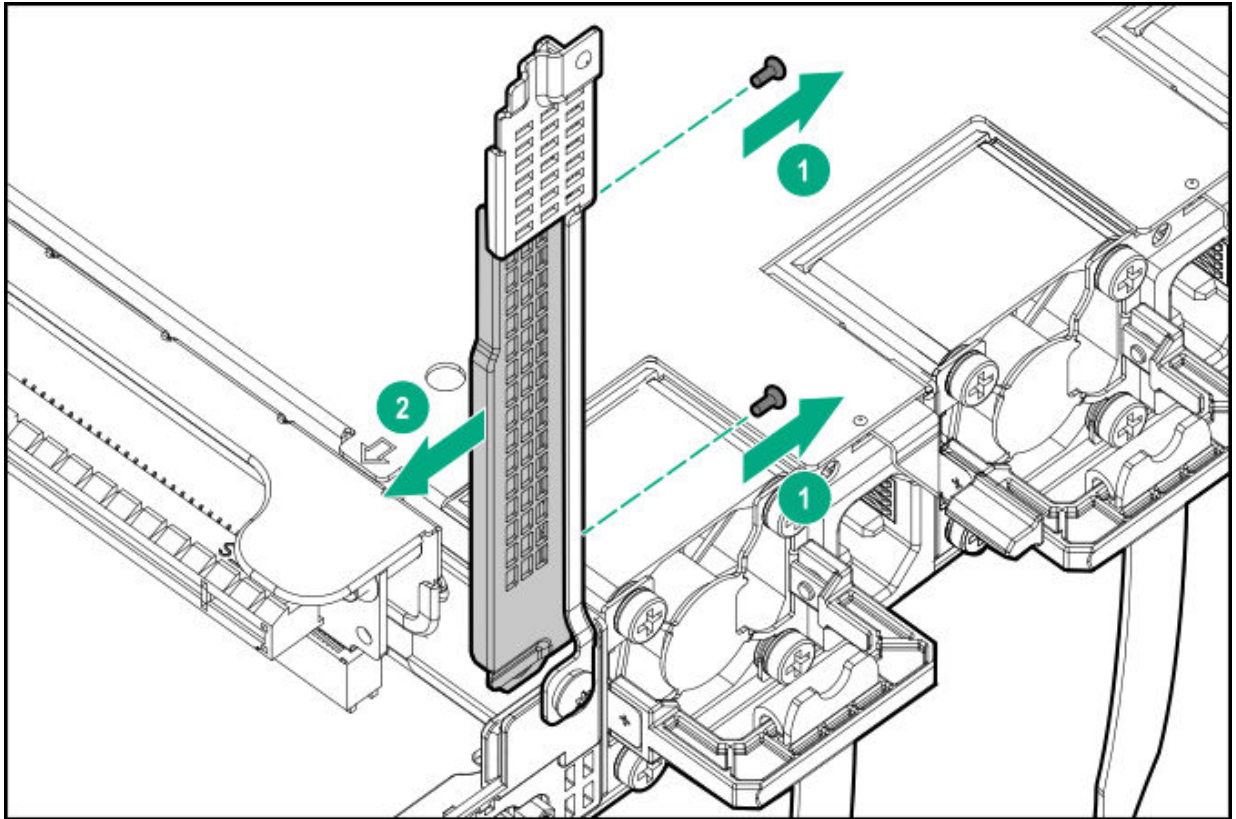

9. Install the expansion board.

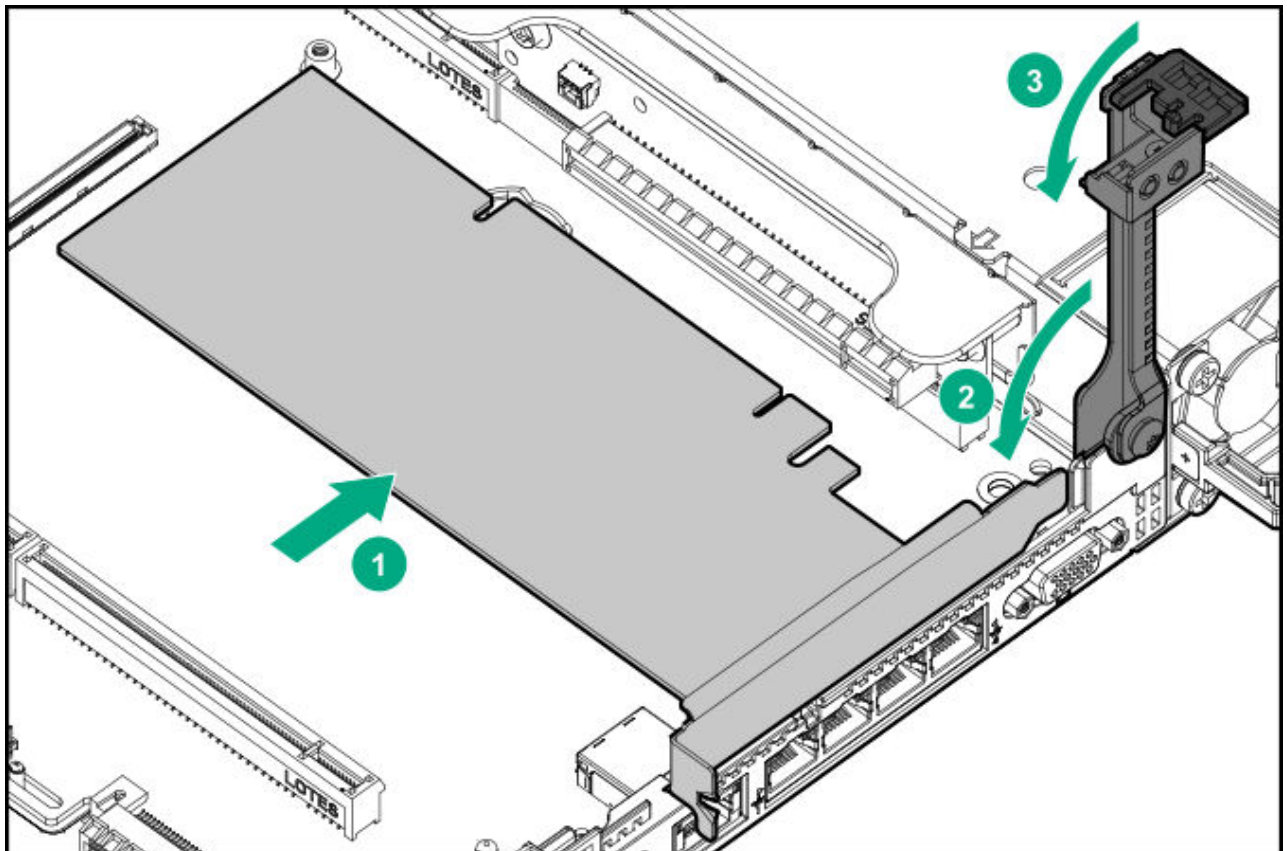

- .0. Connect any required internal or external cables to the expansion board.
- .1. Install the access panel ([Install the access panel](#)).
- .2. Install the server in the rack.
- .3. Connect each power cord to the server.
- .4. Connect each power cord to the power source.
- .5. [Power up the server](#).

## Installing an accelerator or GPU in the secondary riser cage

### Prerequisites

When installing a 3/4-length GPU, a low profile type -a controller must be installed.

Before installing this option, do the following:

- Be sure that the power supplies support the installation of this option. For more information, see the [Hewlett Packard Enterprise Configurator website](#).
- Be sure that you have the following items:
  - The components included with the GPU enablement option kit
  - T-15 Torx screwdriver

### About this task

Use these instructions to install accelerator options, including GPUs, in the server.

### Procedure

1. Observe the following alerts:



**WARNING:** To reduce the risk of personal injury from hot surfaces, allow the drives and the internal system components to cool before touching them.



**CAUTION:** To prevent damage to electrical components, properly ground the server before beginning any installation procedure. Improper grounding can cause electrostatic discharge.

2. Back up all server data.
3. Power down the server ([Power down the server](#)).
4. Remove all power:
  - a. Disconnect each power cord from the power source.
  - b. Disconnect each power cord from the server.
5. Do one of the following:
  - a. Extend the server from the rack ([Extend the server from the rack](#)).
  - b. Remove the server from the rack ([Remove the server from the rack](#)).
6. Remove the access panel ([Remove the access panel](#)).
7. If installed, remove the low profile riser cage.

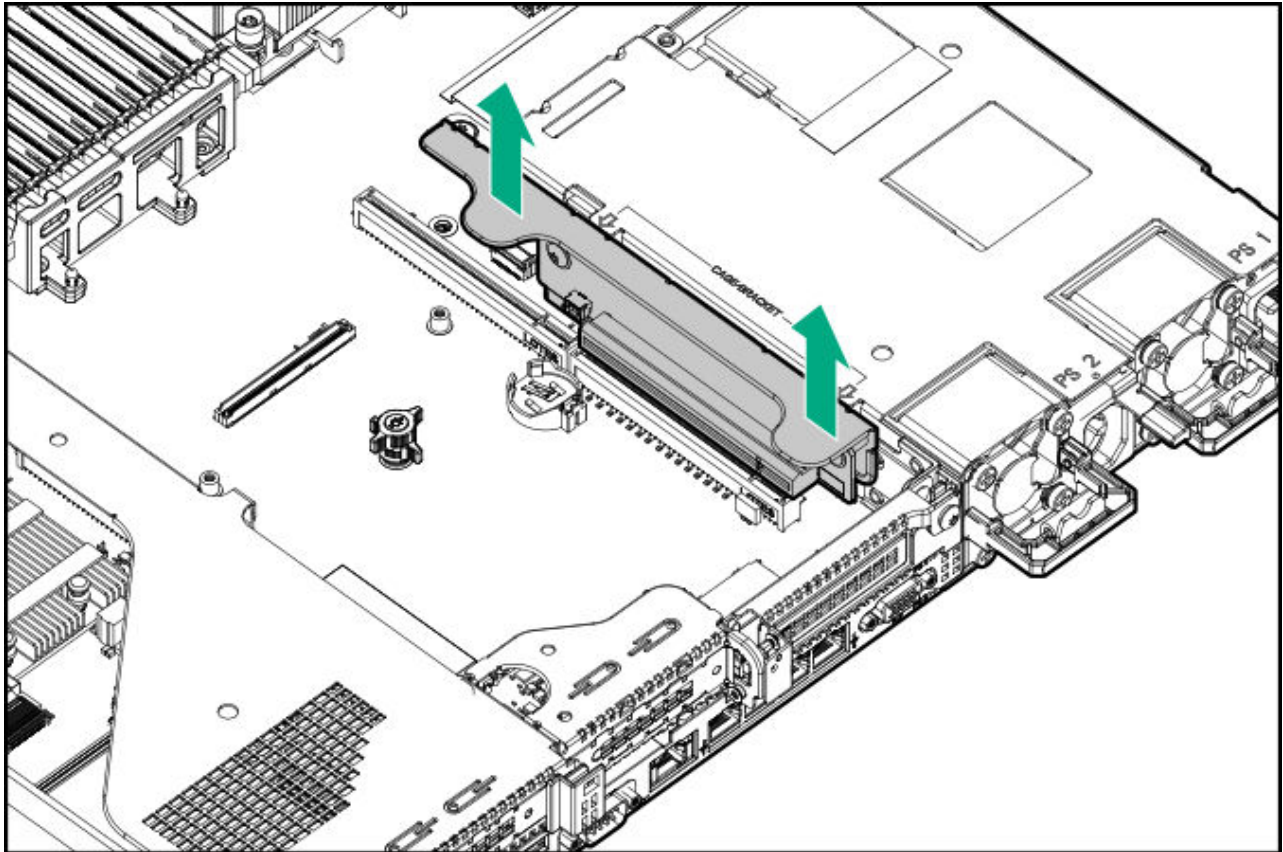

8. Install the secondary full-height PCI riser cage ([Installing a secondary full-height PCI riser cage option](#)).
9. Remove the existing rear guide bracket from the card, if installed.
10. If installing a 3/4-length GPU, install the bracket supplied in the kit.

A T-15 Torx screwdriver is required to install the bracket.

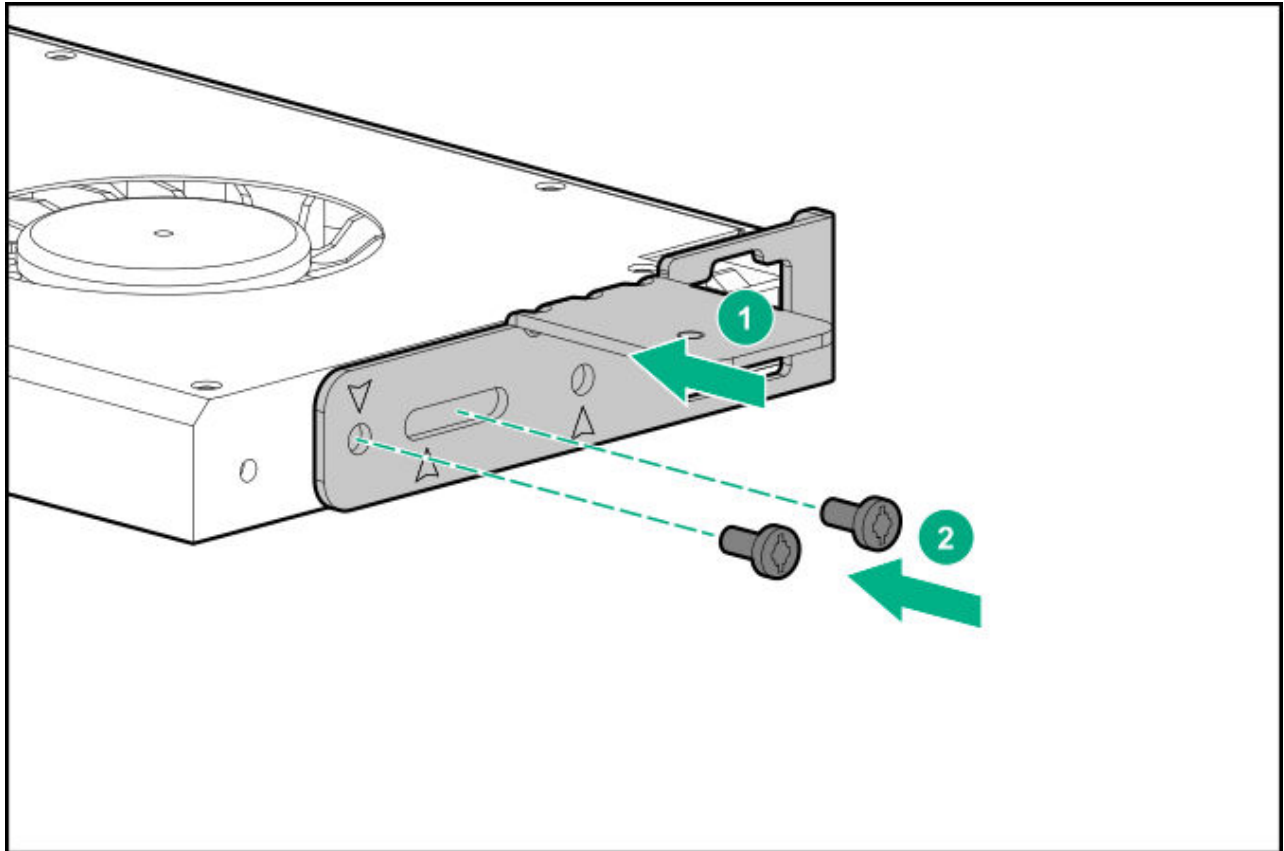

- .1. Install the card in the riser cage, and then connect any required cables, if applicable.
- .2. If installing a GPU requiring greater than 75 W, connect the power cable to the primary riser power connector.

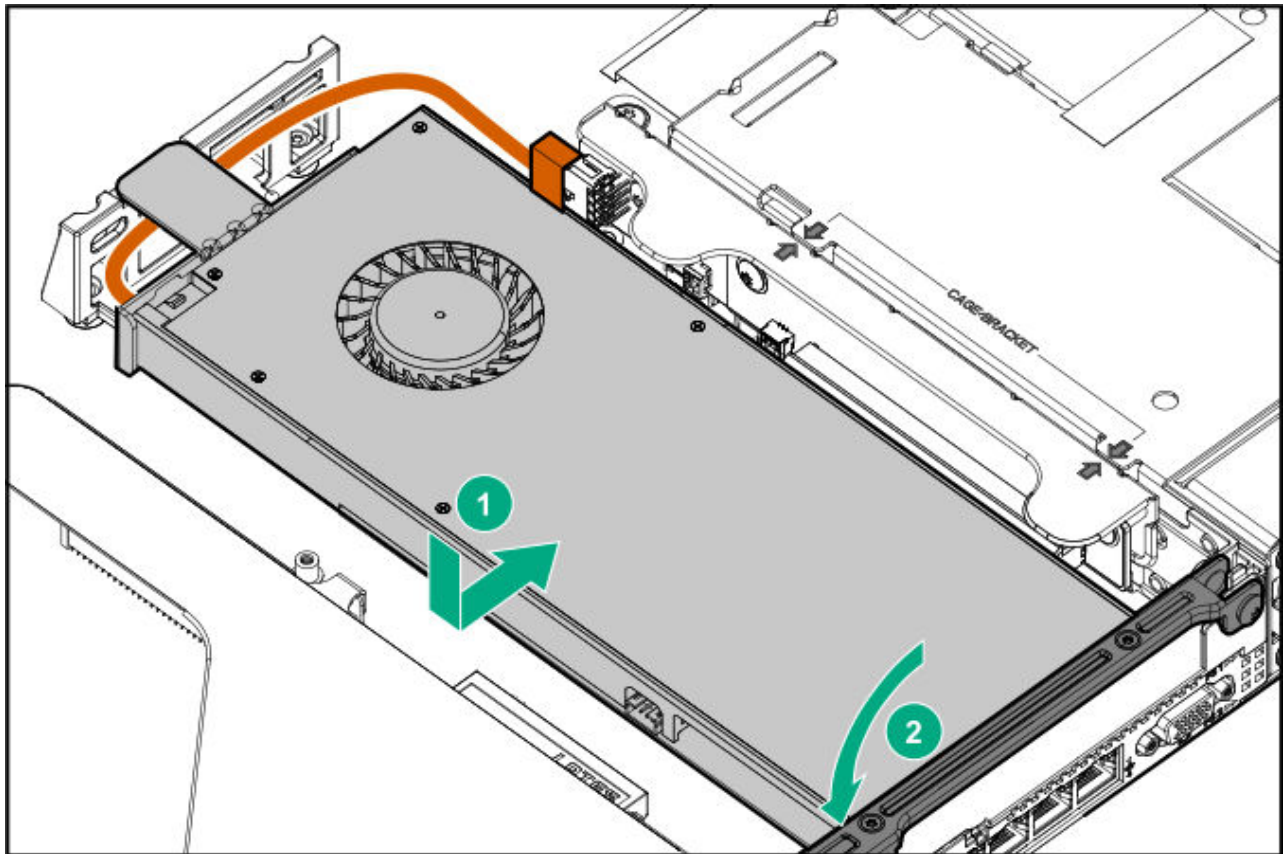

- .3. Install the access panel ([Install the access panel](#)).
- .4. Install the server in the rack.
- .5. Connect each power cord to the server.
- .6. Connect each power cord to the power source.
- .7. Power up the server ([Power up the server](#)).

## Controller options

### Subtopics

[\*\*Installing an HPE Smart Array P408i-a SR Gen10 Controller option\*\*](#)

[\*\*Installing an HPE Smart Array P408i-p SR Gen10 Controller option\*\*](#)

[\*\*Installing an HPE Smart Array P816i-a SR Gen10 Controller option\*\*](#)

[\*\*Installing an HPE Smart Array P824i-p MR Gen10 controller in a configured server\*\*](#)

[\*\*Installing the operating system with the HPE Smart Array MR Gen10 P824i-p controller driver\*\*](#)

# Installing an HPE Smart Array P408i-a SR Gen10 Controller option

## Prerequisites

Before installing this option, be sure that you have the following:

- The components included with the hardware option kit
- T-15 Torx screwdriver

## Procedure

1. Observe the following alerts:



**WARNING:** To reduce the risk of personal injury from hot surfaces, allow the drives and the internal system components to cool before touching them.



**CAUTION:** To prevent damage to electrical components, properly ground the server before beginning any installation procedure. Improper grounding can cause electrostatic discharge.

2. Back up all server data.
3. Power down the server.
4. Remove all power:
  - a. Disconnect each power cord from the power source.
  - b. Disconnect each power cord from the server.
5. Do one of the following:
  - a. Extend the server from the rack.
  - b. Remove the server from the rack.
6. Remove the access panel.
7. Install the controller.

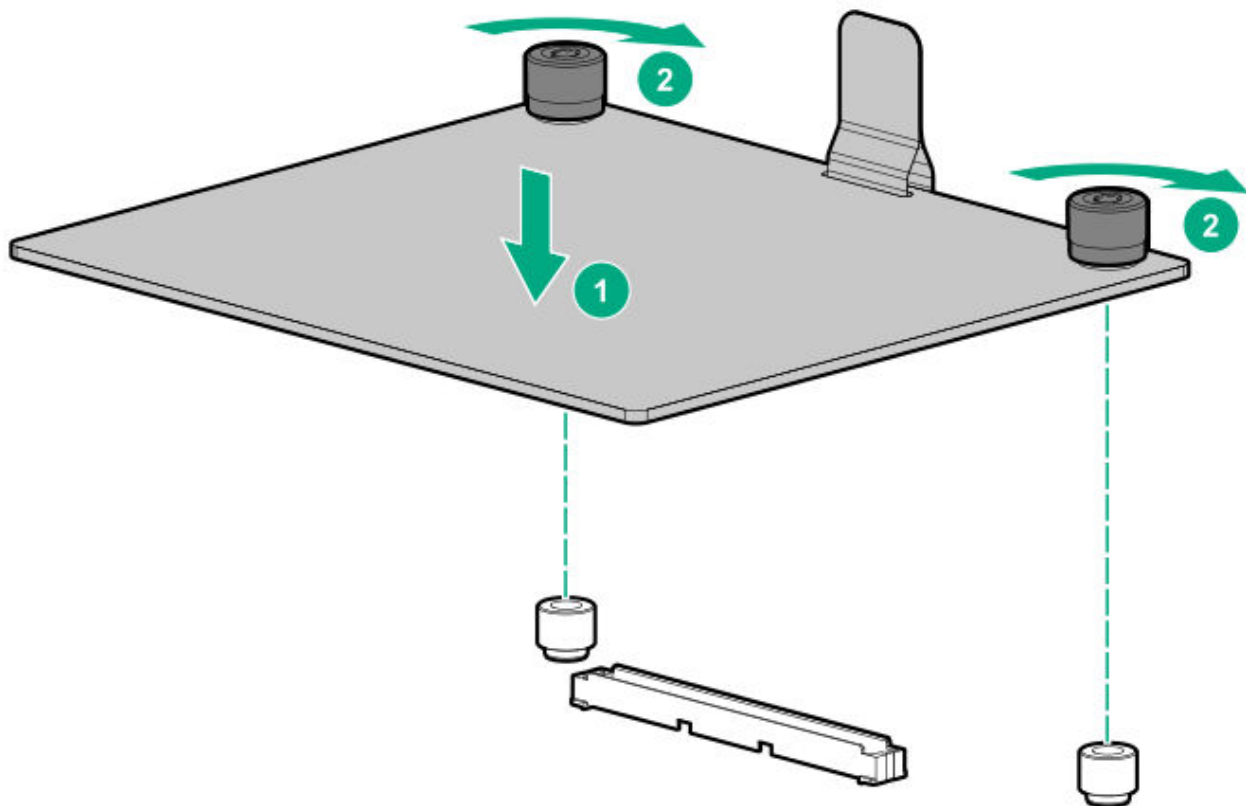

8. Connect the cables.

Additional cabling options are available. For more information, see the HPE DL360 Gen10 Server cabling matrix on the Hewlett Packard Enterprise website (<https://www.hpe.com/info/CablingMatrixGen10>).

- 8 SFF



- 10 SFF SAS/SATA NVMe Combo

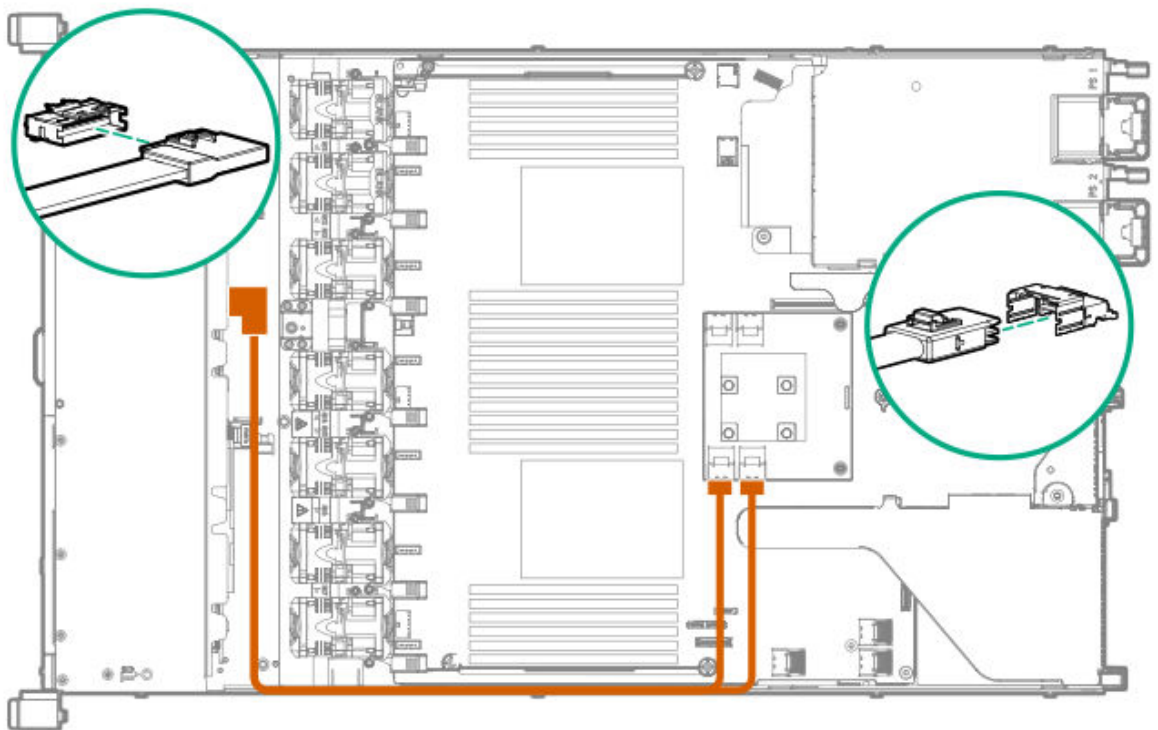

- 4 LFF

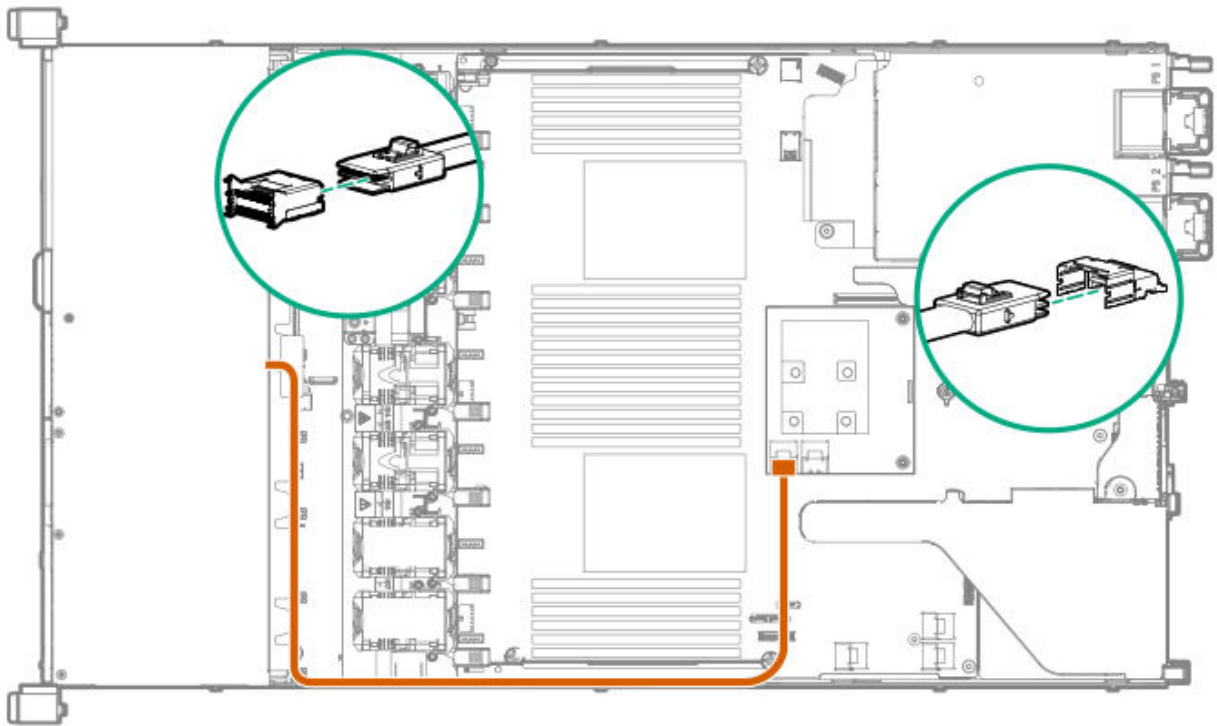

**IMPORTANT:**

To enable SmartCache or CacheCade in a P-class type-p Smart Array controller, you must:

- Connect the controller backup power cable to the controller backup power connector on the system or riser board.
- Connect the energy pack cable to the energy pack connector on the system board.

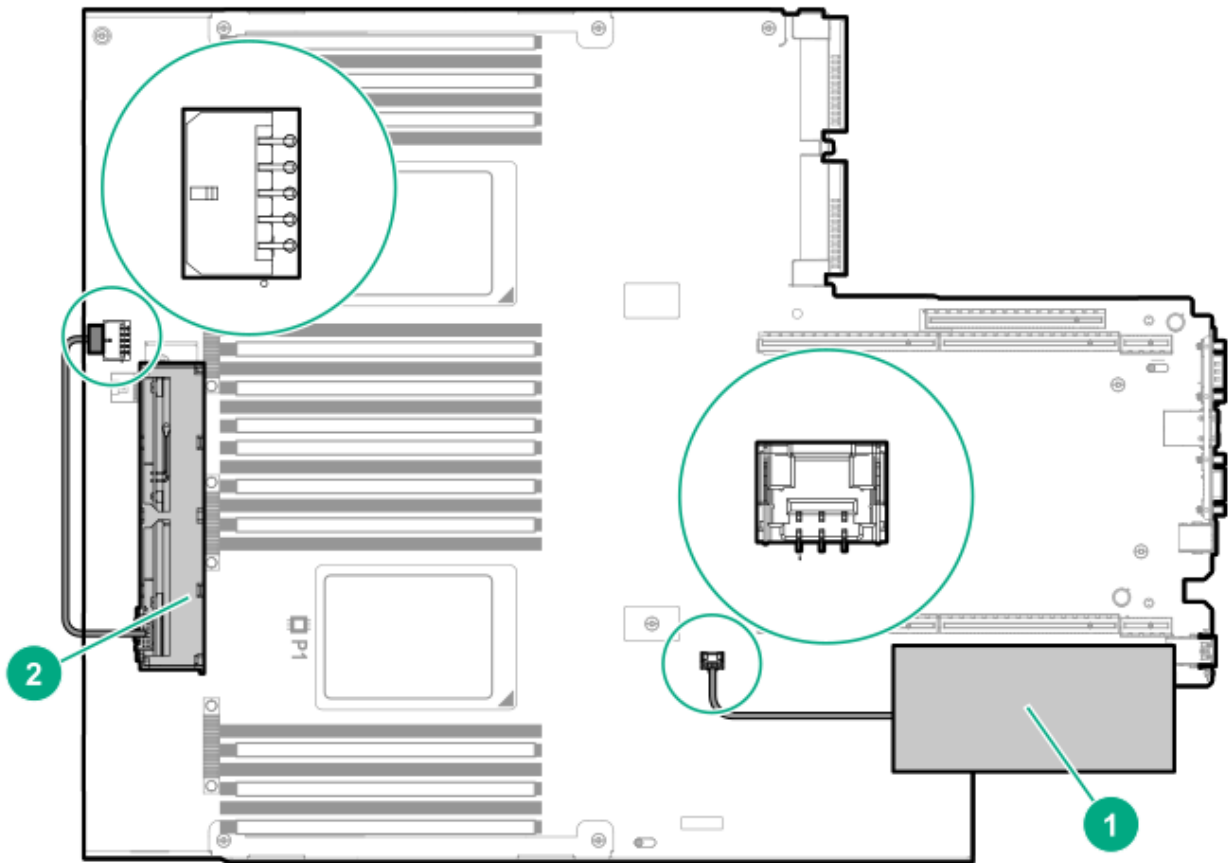

9. Install the access panel.
0. Install the server in the rack.
- .1. Connect each power cord to the server.
- .2. Connect each power cord to the power source.
- .3. Power up the server.

## Installing an HPE Smart Array P408i-p SR Gen10 Controller option

### Prerequisites

Before installing this option, be sure you that have the following:

- The components included with the hardware option kit
- T-10 Torx screwdriver

## Procedure

1. Observe the following alerts:



**WARNING:** To reduce the risk of personal injury from hot surfaces, allow the drives and the internal system components to cool before touching them.



**CAUTION:** To prevent damage to electrical components, properly ground the server before beginning any installation procedure. Improper grounding can cause electrostatic discharge.

2. Back up all server data.
3. Power down the server.
4. Remove all power:
  - a. Disconnect each power cord from the power source.
  - b. Disconnect each power cord from the server.
5. Do one of the following:
  - a. Extend the server from the rack.
  - b. Remove the server from the rack.
6. Remove the access panel.
7. Remove the primary PCI riser cage.
8. Remove the slot 2 expansion board blank.

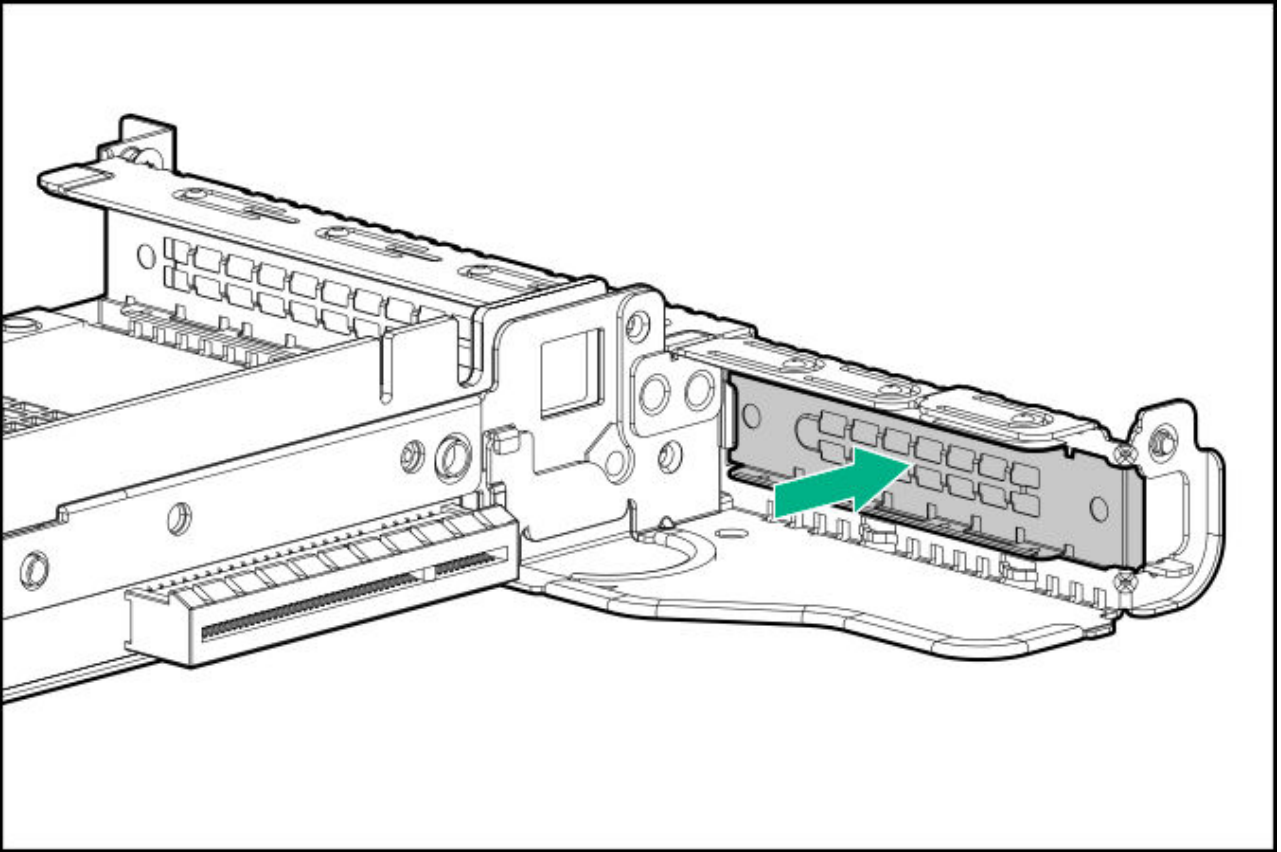

9. Use a Torx T-10 screwdriver to install the controller.

The controller can also be installed in slot 1.

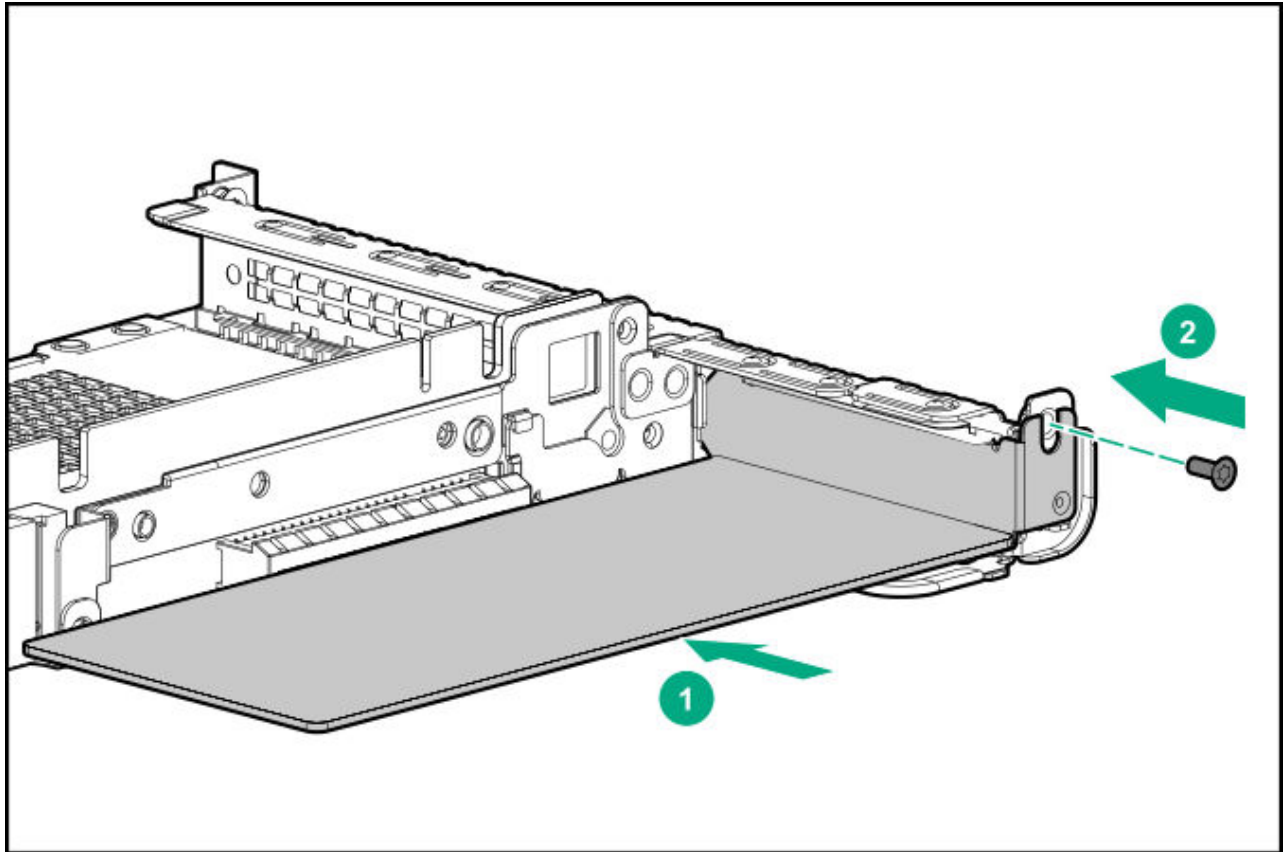

.0. Install the primary PCI riser cage.

.1. Connect the cables.

Additional cabling options are available. For more information, see the HPE DL360 Gen10 Server cabling matrix on the Hewlett Packard Enterprise website (<https://www.hpe.com/info/CablingMatrixGen10>).

- 8 SFF

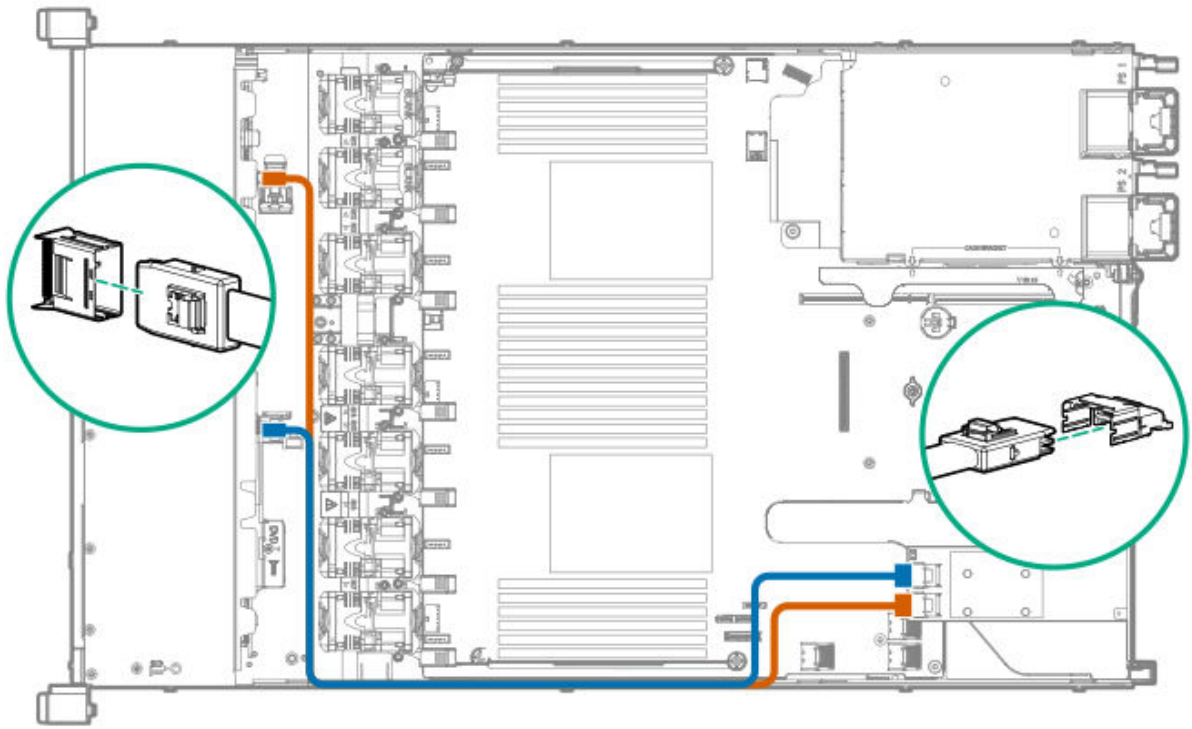

- 4 LFF

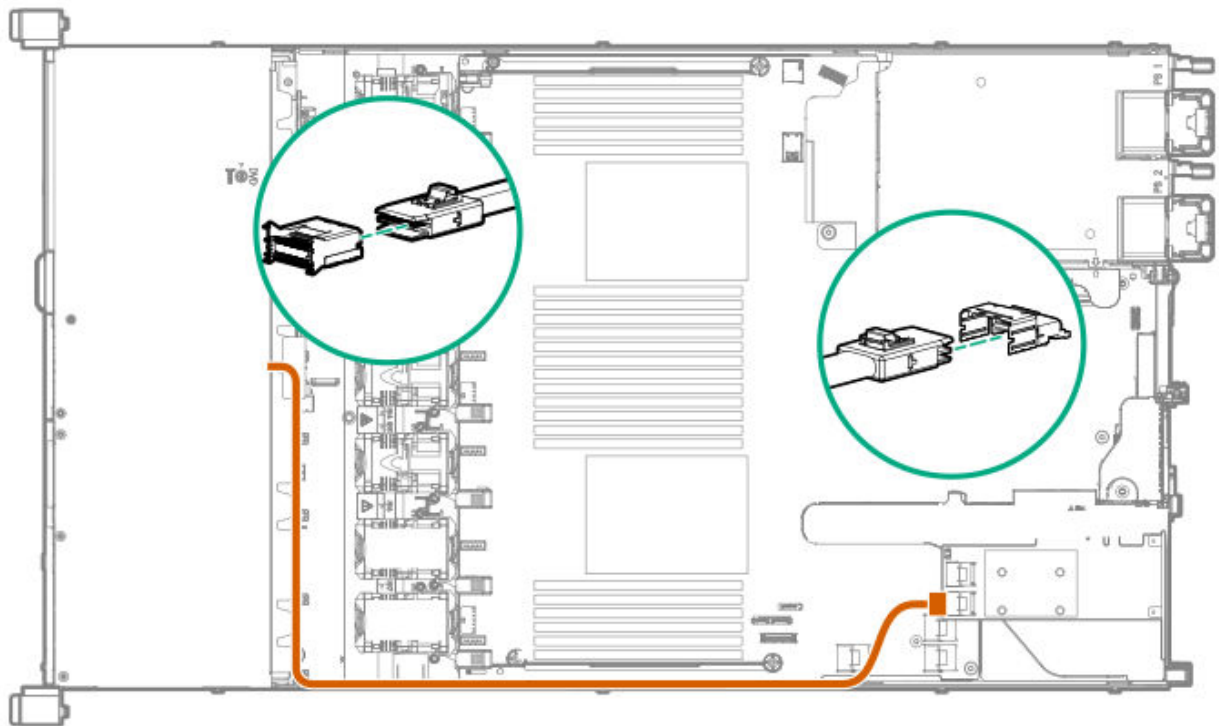



**IMPORTANT:**

To enable SmartCache or CacheCade in a P-class type-p Smart Array controller, you must:

- Connect the controller backup power cable to the controller backup power connector on the system or riser board.
- Connect the energy pack cable to the energy pack connector on the system board.

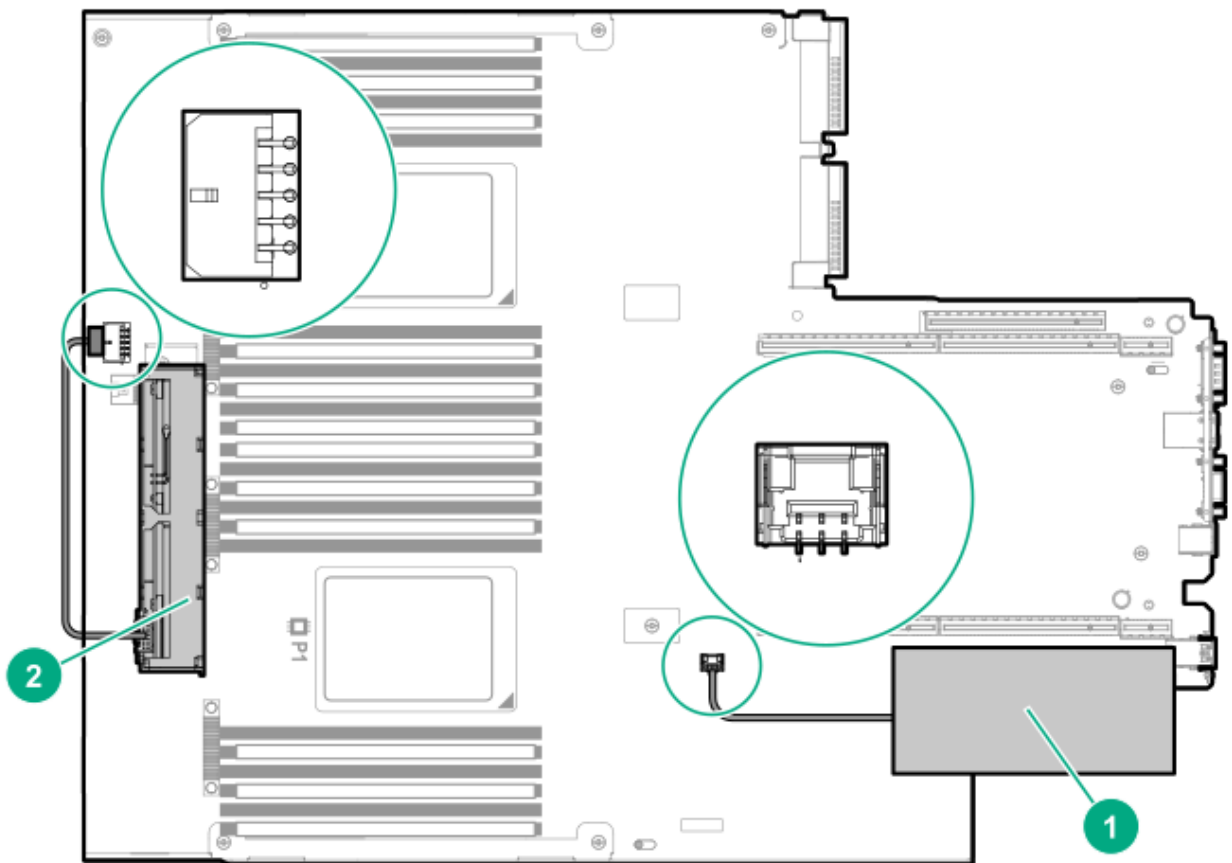

- .2. Install the access panel.
- .3. Install the server in the rack.
- .4. Connect each power cord to the server.
- .5. Connect each power cord to the power source.

- .6. Power up the server.

## Installing an HPE Smart Array P816i-a SR Gen10 Controller option

### Prerequisites

Before installing this option, be sure that you have the following:

- The components included with the hardware option kit
- Additional cables, as required. For more information, see [Cabling](#)
- T-15 Torx screwdriver

### Procedure

1. Observe the following alerts:



**WARNING:** To reduce the risk of personal injury from hot surfaces, allow the drives and the internal system components to cool before touching them.



**CAUTION:** To prevent damage to electrical components, properly ground the server before beginning any installation procedure. Improper grounding can cause electrostatic discharge.

2. Back up all server data.
3. Power down the server.
4. Remove all power:
  - a. Disconnect each power cord from the power source.
  - b. Disconnect each power cord from the server.
5. Do one of the following:
  - a. Extend the server from the rack.
  - b. Remove the server from the rack.
6. Remove the access panel.
7. Install the controller.

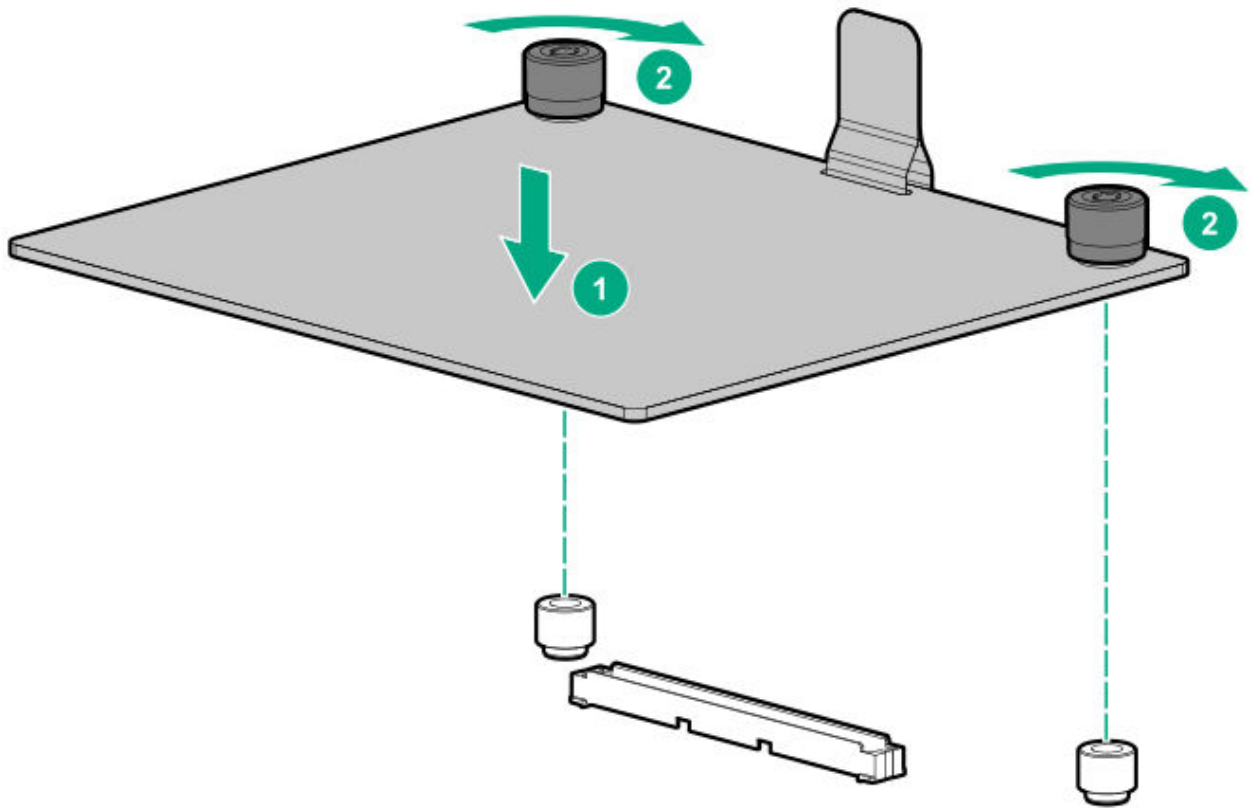

8. Connect the cables.

The following illustration shows the 8+2 SFF backplane configuration connected to the controller. Additional cabling options are available. For more information, see the HPE DL360 Gen10 Server cabling matrix on the Hewlett Packard Enterprise website (<https://www.hpe.com/info/CablingMatrixGen10>).

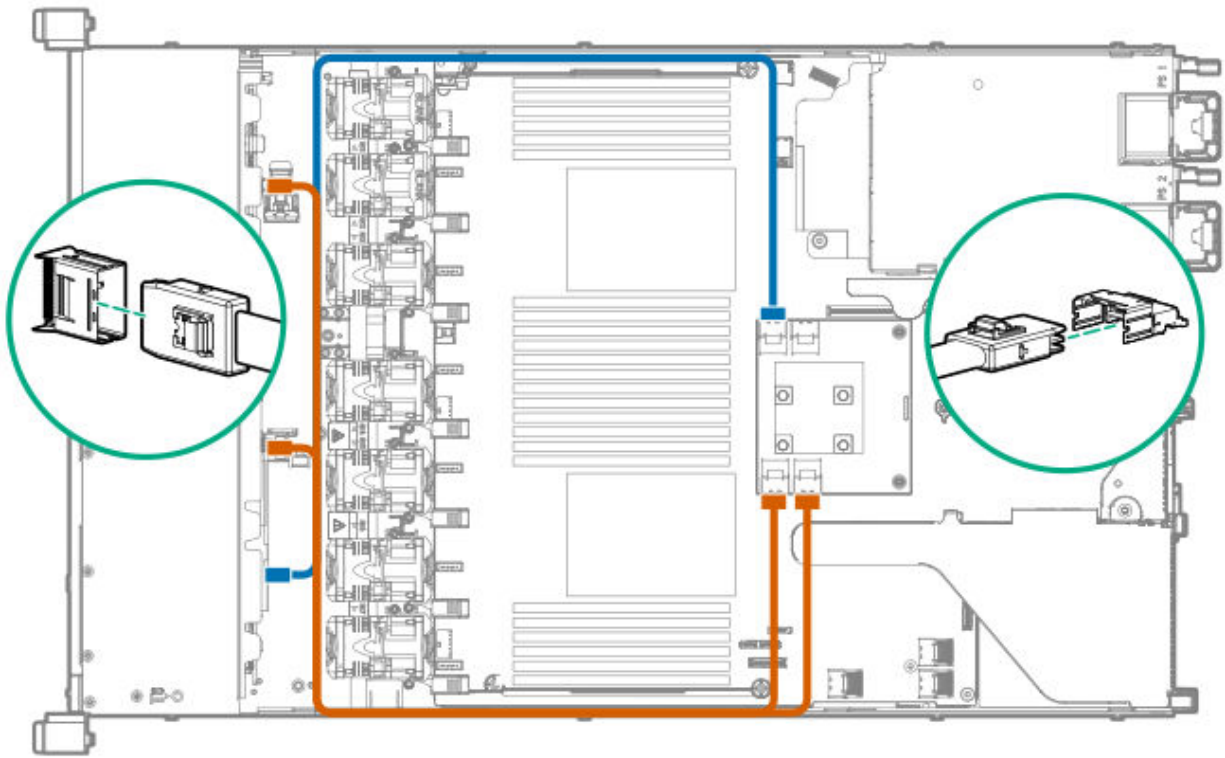

**IMPORTANT:**

To enable SmartCache or CacheCade in a P-class type-p Smart Array controller, you must:

- Connect the controller backup power cable to the controller backup power connector on the system or riser board.
- Connect the energy pack cable to the energy pack connector on the system board.

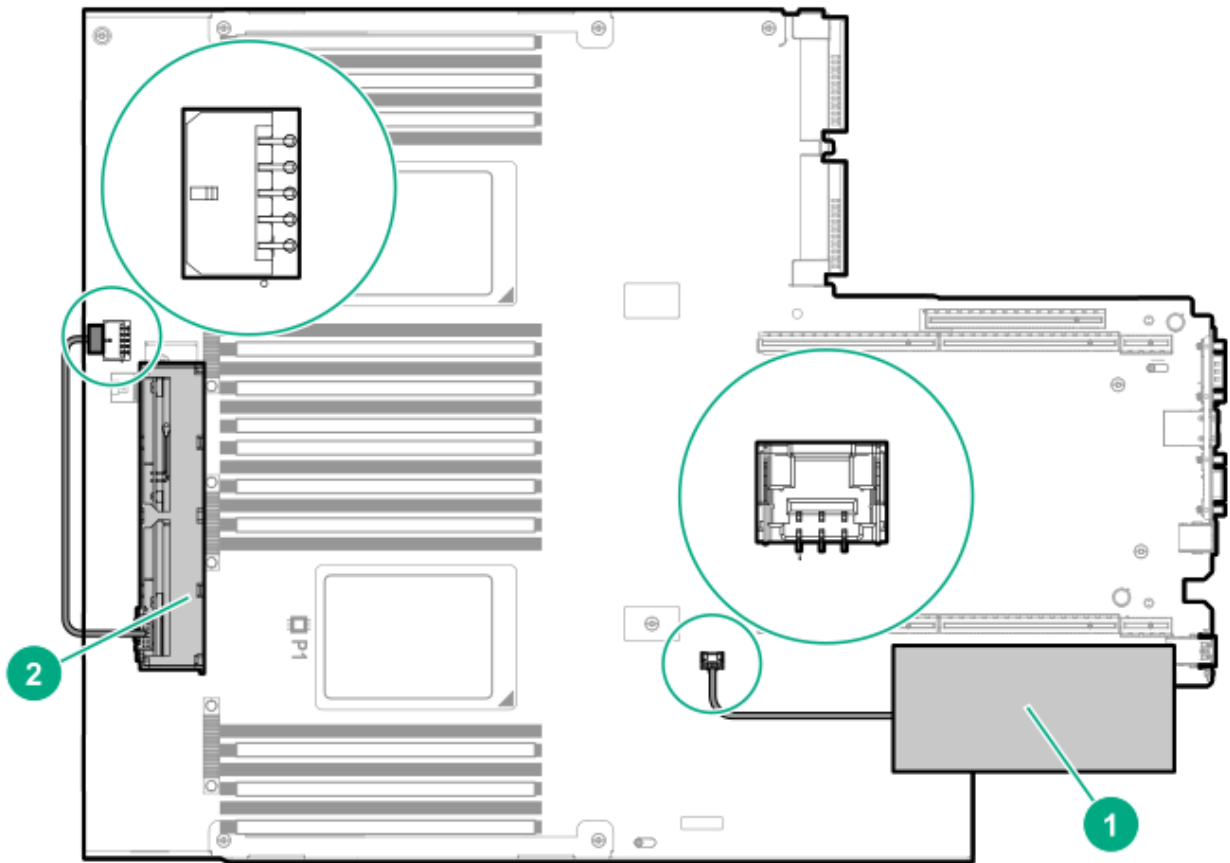

9. Install the access panel.
- .0. Install the server in the rack.
- .1. Connect each power cord to the server.
- .2. Connect each power cord to the power source.
- .3. Power up the server.

## Installing an HPE Smart Array P824i-p MR Gen10 controller in a configured server

### Procedure

1. Back up data on the system.
2. Close all applications.

3. Update the server firmware if it is not the latest revision.
4. Do one of the following:
  - If the new Smart Array is the new boot device, install the device drivers.
  - If the new Smart Array is not the new boot device, go to the next step.

**NOTE:**

If the logical drive is used in a Smart Array SR controller RAID array, you are not able to boot from that device if you are attached to a Smart Array MR controller.

5. Ensure that users are logged off and all tasks are completed on the server.
6. Power down the server.

**CAUTION:**

In systems that use external data storage, be sure that the server is the first unit to be powered down and the last to be powered back up. Taking this precaution ensures that the system does not erroneously mark the drives as failed when the server is powered up.

7. Power down all peripheral devices that are attached to the server.
8. Disconnect the power cord from the power source.
9. Disconnect the power cord from the server.
10. Remove or open the access panel.

**WARNING:**

To reduce the risk of personal injury from hot surfaces, allow the drives and the internal system components to cool before touching them.

1. Remove the riser.
2. Select an available x8 or larger PCIe expansion slot.

A x8 physical size slot is required, even though the slot width may be electrically x4 or x1. Hewlett Packard Enterprise recommends using a slot that is electrically x8.

3. Remove the slot cover.

Save the retaining screw, if one is present.

- .4. Slide the controller along the slot alignment guide, if one is present, and then press the board firmly into the expansion slot so that the contacts on the board edge are seated properly in the slot.
- .5. Secure the controller in place with the retaining screw. If the slot alignment guide has a latch (near the rear of the board), close the latch.
- .6. Connect the controller backup power cable.



**IMPORTANT:**

To enable SmartCache or CacheCade in a P-class type-p Smart Array controller, you must:

- Connect the controller backup power cable to the controller backup power connector on the system or riser board.
- Connect the energy pack cable to the energy pack connector on the system board.

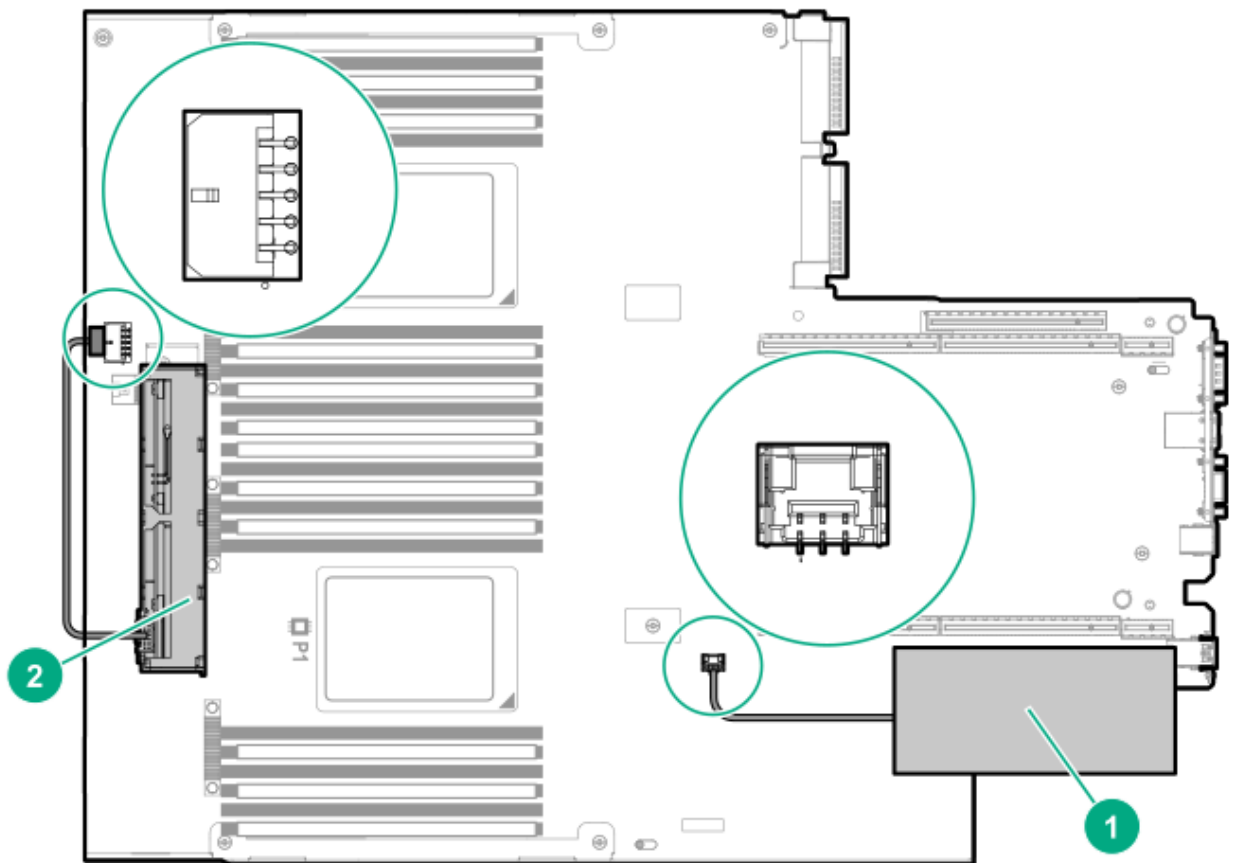

.7. Connect storage devices to the controller.

For cabling information, see the server user guide.

.8. Install the HPE Smart Storage Battery or HPE Smart Storage Hybrid Capacitor.

.9. Reinstall the riser.

!0. Connect peripheral devices to the server.

!1. Connect the power cord to the server.

!2. Connect the power cord to the power source.

!3. Power up all peripheral devices.

!4. Power up the server.

## Installing the operating system with the HPE Smart Array MR Gen10 P824i-p controller driver

### Prerequisites

Ensure that you have the HPE Smart Array MR Gen10 P824i-p controller driver available. Obtain it by extracting it from the SPP (<https://www.hpe.com/servers/spp>) or by downloading it from the Hewlett Packard Enterprise Support Center <https://www.hpe.com/support/hpesc>.

### Procedure

1. Power on the server.
2. If you are running the server in UEFI Boot Mode, select **F9 (System Utilities)**.
3. (Optional) If running the server in Legacy Boot Mode, set the controller as the boot controller.
4. (Optional) If running the server in Legacy Boot Mode, change the controller boot order.
5. Configure a logical drive or select physical drives for JBOD mode using the Smart Array configuration utility in UEFI System Utilities.
6. Launch the operating system installation and point to the controller driver when prompted.
7. If the operating system utility does not see the drive, repeat the step to configure the logical drive or select physical drives for JBOD and retry the installation.
8. After the installation is complete, use MR Storage Administrator, StorCLI, or the SPP to update the controller firmware if it is not the latest revision.

# Processor and heatsink options

## Subtopics

[Installing a processor heatsink assembly](#)

[Installing a high performance heatsink](#)

## Installing a processor heatsink assembly

### Prerequisites

Before installing this option, be sure that you have the following items:

- Processor or heatsink kit contents
- T-30 Torx screwdriver

### About this task

The server supports single-processor and dual processor operations.



#### **IMPORTANT:**

Existing HPE ProLiant and HPE Synergy Gen10 server products containing first-generation Intel Xeon Scalable processors may not be upgraded to second-generation Intel Xeon Scalable processors at this time.

Hewlett Packard Enterprise recommends identifying the processor heatsink module components before performing this procedure. See [Processor, heatsink, and socket components](#).

## Procedure

1. Observe the following alerts.



**CAUTION:** When handling the heatsink, always hold it along the top and bottom of the fins. Holding it from the sides can damage the fins.



**CAUTION:** To prevent possible server malfunction and damage to the equipment, multiprocessor configurations must contain processors with the same part number.



**CAUTION:** If installing a processor with a faster speed, update the system ROM before installing the processor.

To download the firmware and view installation instructions, see the **[Hewlett Packard Enterprise Support Center website](#)**.



**CAUTION: THE CONTACTS ARE VERY FRAGILE AND EASILY DAMAGED.**

To avoid damage to the socket or processor, do not touch the contacts.

2. Power down the server ([Power down the server](#)).
3. Remove all power:
  - a. Disconnect each power cord from the power source.
  - b. Disconnect each power cord from the server.
4. Remove the server from the rack ([Remove the server from the rack](#)).
5. Remove the access panel ([Remove the access panel](#)).
6. Remove the dust cover from the processor socket you intend to upgrade.
7. Install the processor heatsink assembly:
  - a. Locate and align the Pin 1 indicator on the processor carrier and the socket.
  - b. Align the processor-heatsink module with the heatsink alignment pins and gently lower it down until it sits evenly on the socket.

The heatsink alignment pins are keyed. The processor will only install one way.

Your heatsink may look different than the one shown.

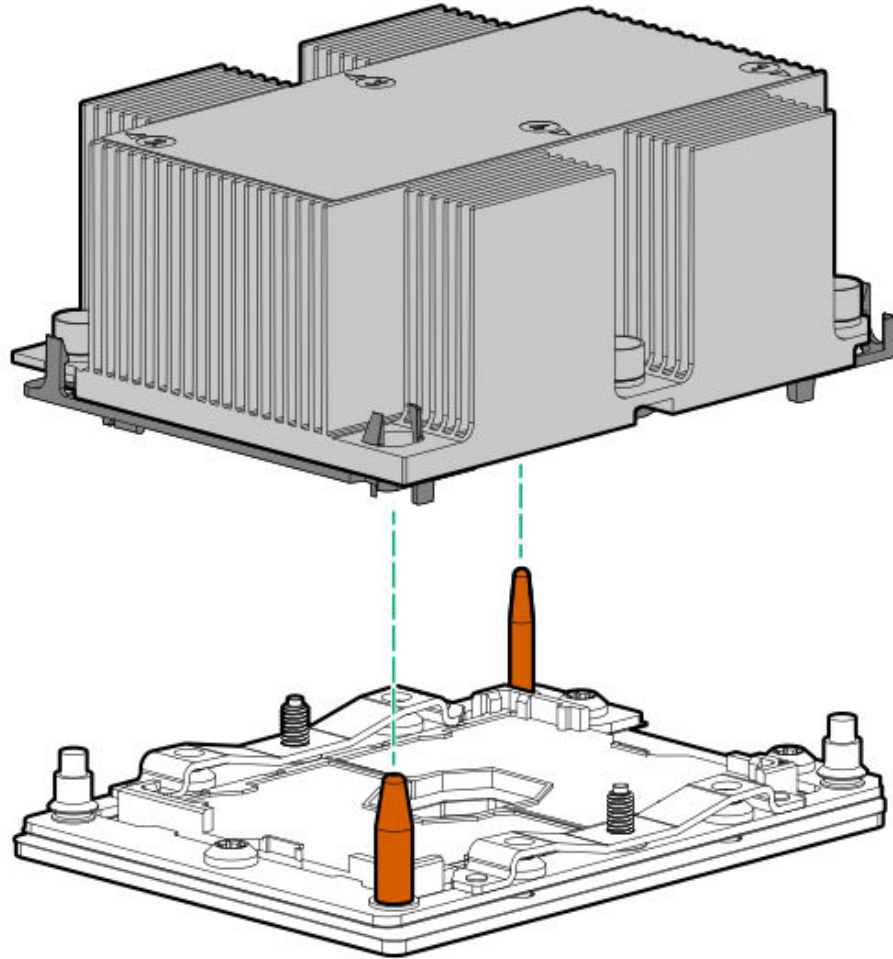

**CAUTION:** Be sure to tighten each nut or screw in the order indicated. Otherwise, boot failure or intermittent shutdowns might occur.

- c. Using a T-30 Torx screwdriver, fully tighten each heatsink nut in the order indicated on the heatsink label (1 -2 -3 -4) until it no longer turns.

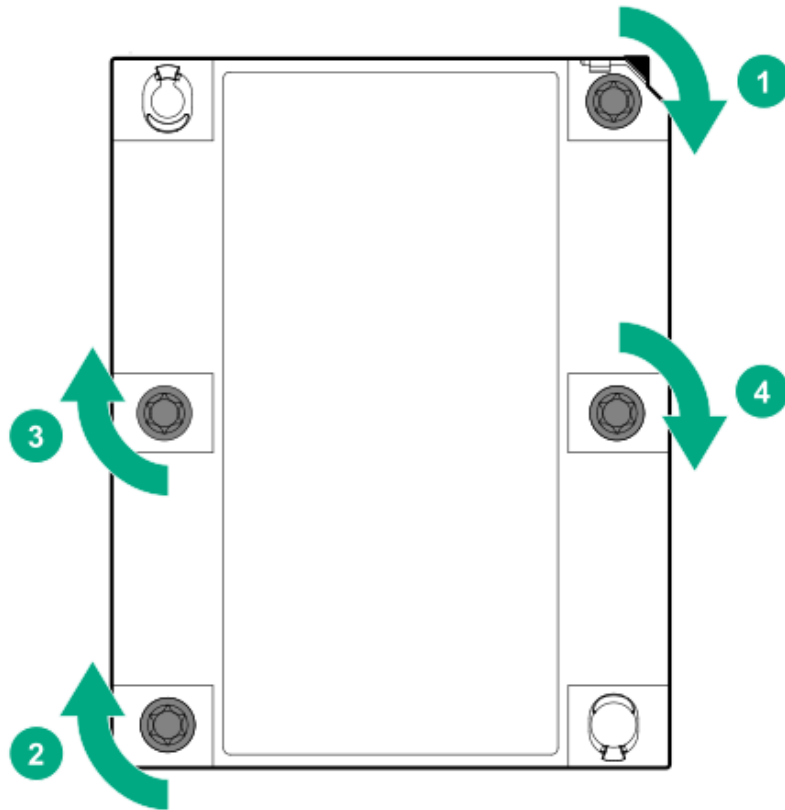

8. If installing a second processor, install high-performance fans in bays 7 and 8. These fans are provided with the processor option kit.
9. Install the access panel ([Install the access panel](#)).
10. Install the server in the rack.
11. Connect each power cord to the server.
12. Connect each power cord to the power source.
13. Power up the server ([Power up the server](#)).

## Installing a high performance heatsink

### Prerequisites



**CAUTION:** Installing a high performance heatsink requires the installation of a processor assembly onto the heatsink. To avoid damage to server or components, do not remove or install the processor assembly when installing or replacing other heatsinks.

To determine when a high performance heatsink should be installed in the server, see the server QuickSpecs on the Hewlett Packard Enterprise (<https://www.hpe.com/info/qs>).

Before installing this option, be sure that you have the following:

- The components included with the hardware option kit
- T-30 Torx screwdriver
- 1/4 in flat blade screwdriver or nonconductive tool  
Hewlett Packard Enterprise recommends using a nonconductive tool.

## Procedure

1. Observe the following alerts.



**CAUTION:** The processor and carrier must be removed and replaced as a unit.  
Do not remove the processor from the carrier.



**CAUTION:** When handling the heatsink, always hold it along the top and bottom of the fins. Holding it from the sides can damage the fins.



**CAUTION: THE CONTACTS ARE VERY FRAGILE AND EASILY DAMAGED.**  
To avoid damage to the socket or processor, do not touch the contacts.

2. Power down the server.
3. Remove all power:
  - a. Disconnect each power cord from the power source.
  - b. Disconnect each power cord from the server.
4. Do one of the following:
  - a. Extend the server from the rack.
  - b. Remove the server from the rack.
5. Remove the access panel.

6. Observe the following cautions.



**CAUTION:** Loosen each nut or screw in the order indicated. Otherwise, damage might occur to components.



**CAUTION:** Install the processor as soon as possible after removing it. Do not leave the socket unpopulated for extended periods of time.

7. Remove the existing processor heatsink assembly:

- a. Allow the heatsink to cool.
- b. Using a T-30 Torx screwdriver, loosen the heatsink nuts.

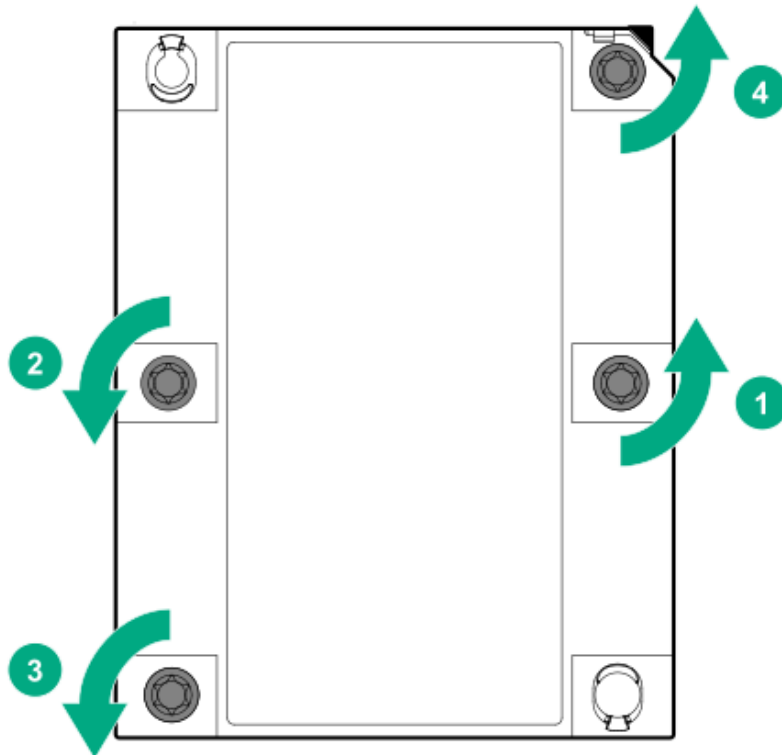

- c. Lift the processor heatsink assembly up and away from the system board.
- d. Turn the processor heatsink assembly over and place it on a work surface with the processor assembly facing up.

8. Release the thermal grease adhesion between the processor assembly and heatsink:

- a. Locate the TIM (thermal interface media) breaker slot between the processor assembly and heatsink.

The slot is across from the Pin 1 indicator, near the corner.

- b. Insert a 1/4" flat blade screwdriver or nonconductive tool into the slot.



**CAUTION:** To avoid damage to the processor, insert the tool between the processor and the heatsink base. The opening in the carrier provides access to a gap between the processor heatsink spreader and the heatsink base.

- c. To release the adhesion of the thermal grease, gently rotate the tool.

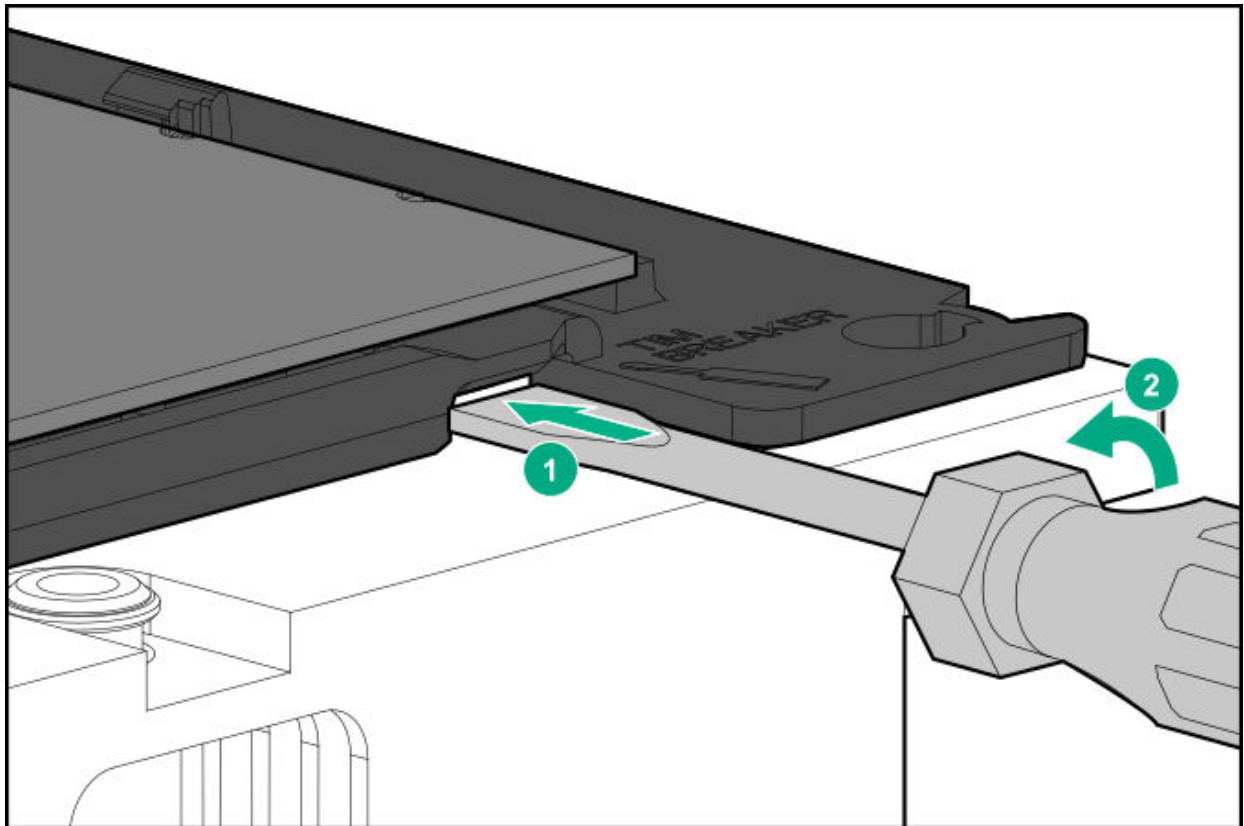

- d. Unlatch the remaining corners of the processor assembly.
- e. Separate the processor assembly from the heatsink.

The processor remains attached to the carrier.

9. Using an alcohol wipe, remove the existing thermal grease from the processor and heatsink. Allow the alcohol to evaporate before continuing.
- .0. Remove the plastic cover over the thermal grease on the high performance heatsink.
- .1. Install the processor assembly on the heatsink.

Align the Pin 1 indicator on the processor to the Pin 1 indicator on the heatsink, and then latch the processor assembly to the heatsink.

Your heatsink may look different than the one shown.

.2. Install the processor heatsink assembly:

- a. Locate the Pin 1 indicator on the processor carrier and the socket.
- b. Align the processor heatsink assembly with the heatsink alignment pins and gently lower it down until it sits evenly on the socket.

The heatsink alignment pins are keyed. The processor heatsink assembly will only install one way.

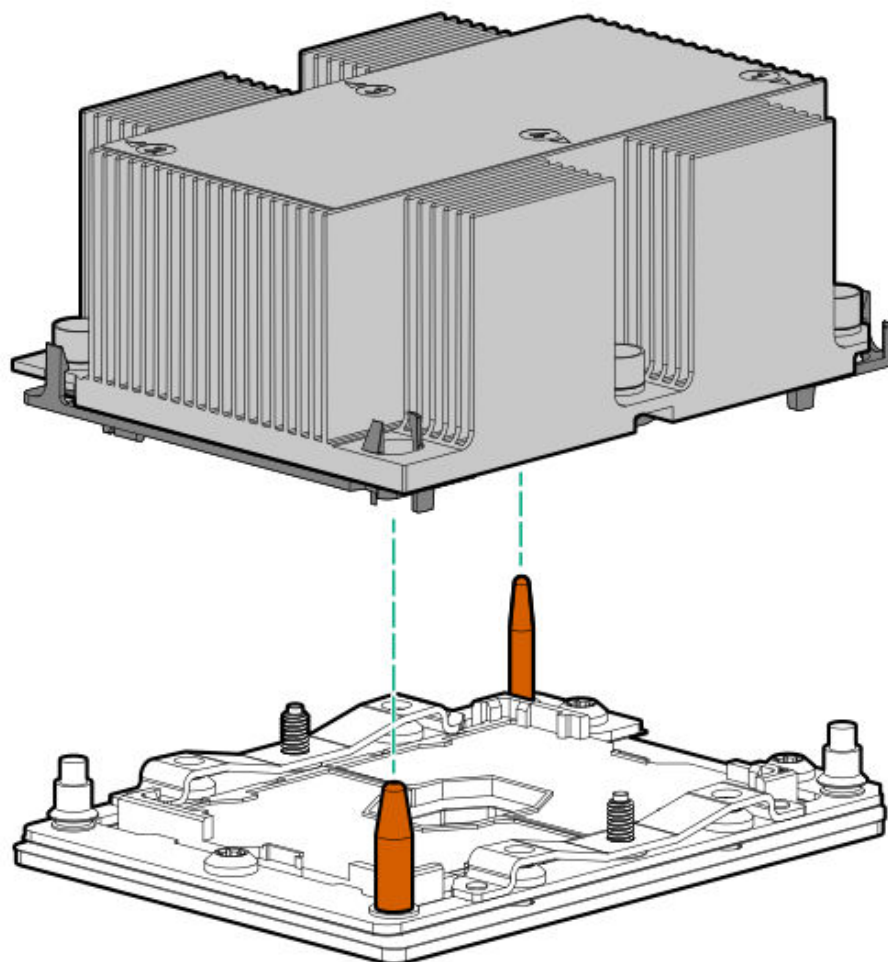

c.



**CAUTION:** Be sure to tighten each nut or screw in the order indicated. Otherwise, boot failure or intermittent shutdowns might occur.

Using a T-30 Torx screwdriver, fully tighten each heatsink nut until it no longer turns.

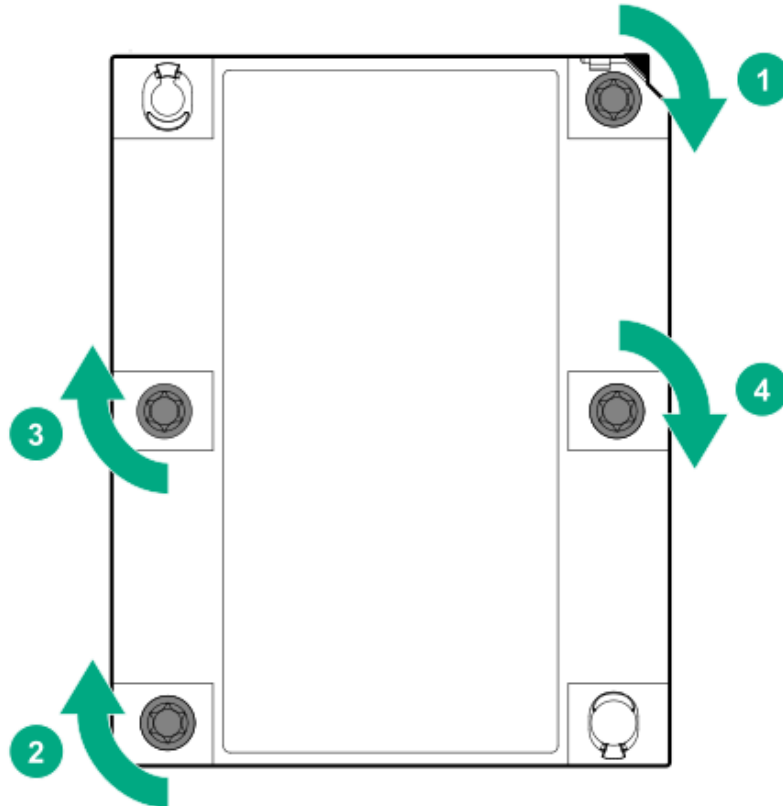

## Installing the Systems Insight Display power module

### Prerequisites

Before installing this option, be sure you have the following:

- The components included with the hardware option kit
- T-10 Torx screwdriver

## Procedure

1. Observe the following alerts:



**WARNING:** To reduce the risk of personal injury from hot surfaces, allow the drives and the internal system components to cool before touching them.



**CAUTION:** To prevent damage to electrical components, properly ground the server before beginning any installation procedure. Improper grounding can cause electrostatic discharge.

2. Back up all server data.
3. Power down the server (Power down the server).
4. Remove all power:
  - a. Disconnect each power cord from the power source.
  - b. Disconnect each power cord from the server.
5. Do one of the following:
  - a. Extend the server from the rack (Extend the server from the rack).
  - b. Remove the server from the rack (Remove the server from the rack).
6. Remove the access panel (Remove the access panel).
7. Disconnect the Power/UID/USB cable from the front power button/USB 3.0 on the system board.

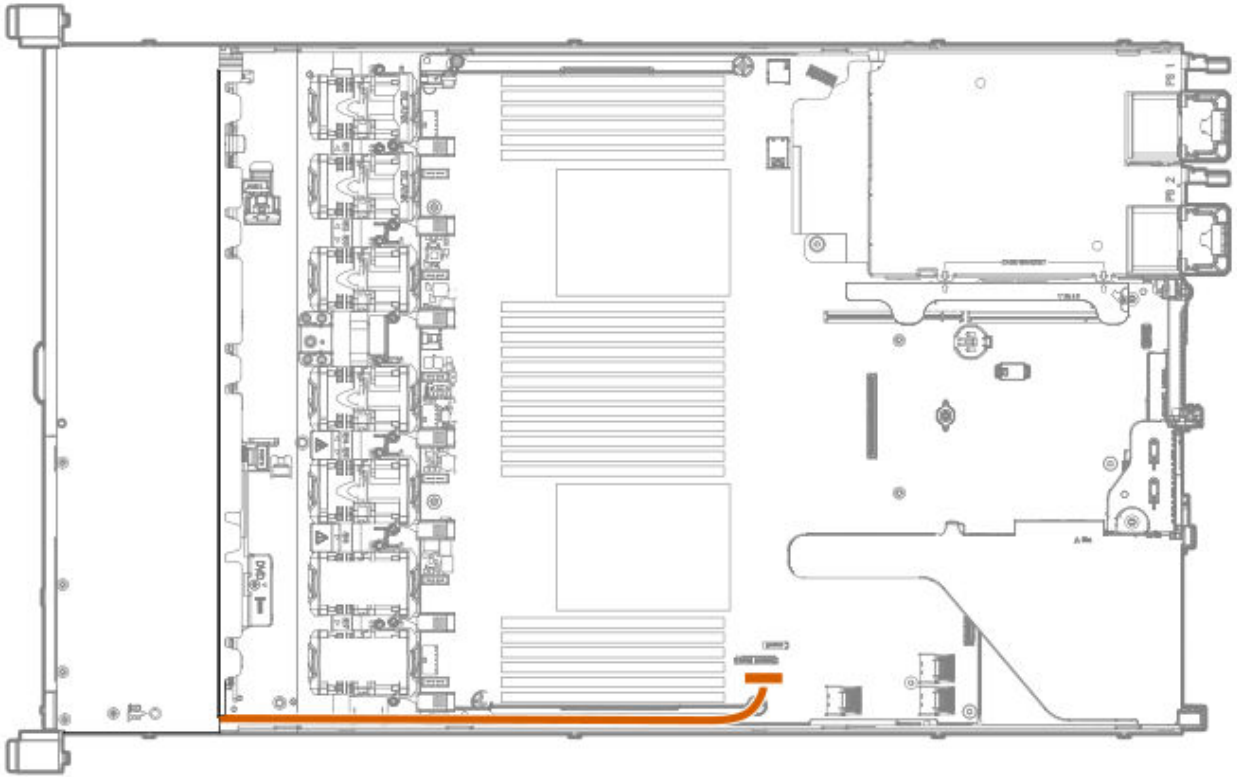

8. Using a Torx T-10 screwdriver, remove the Power/UID/USB assembly.

- 8 SFF

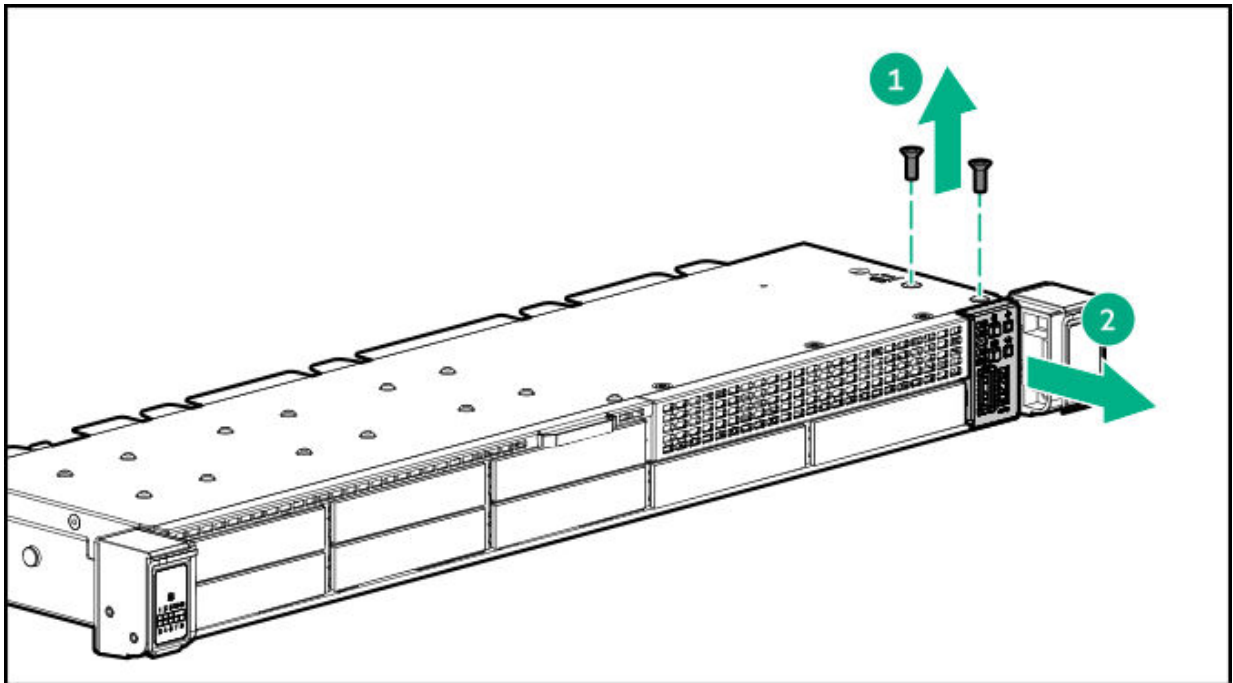

- 4 LFF

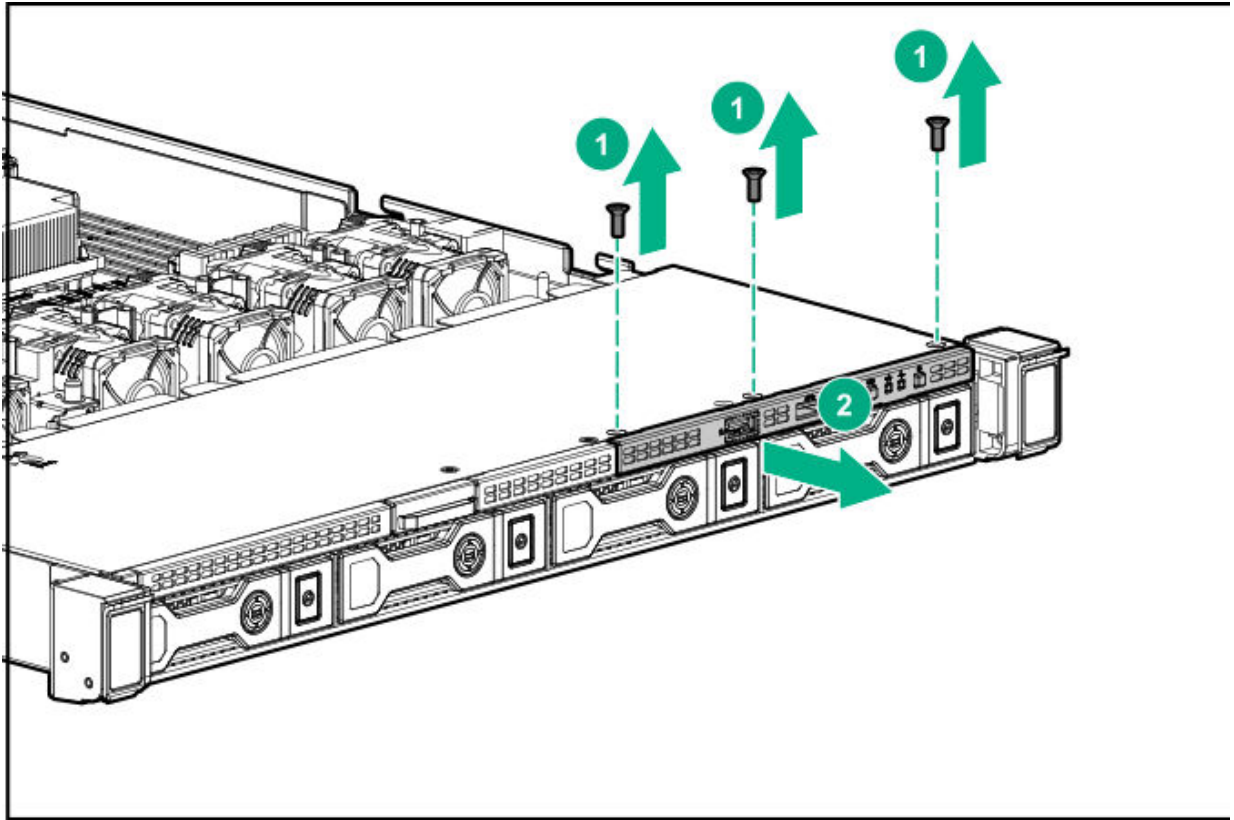

9. Guide the SID cable through the front of the server.

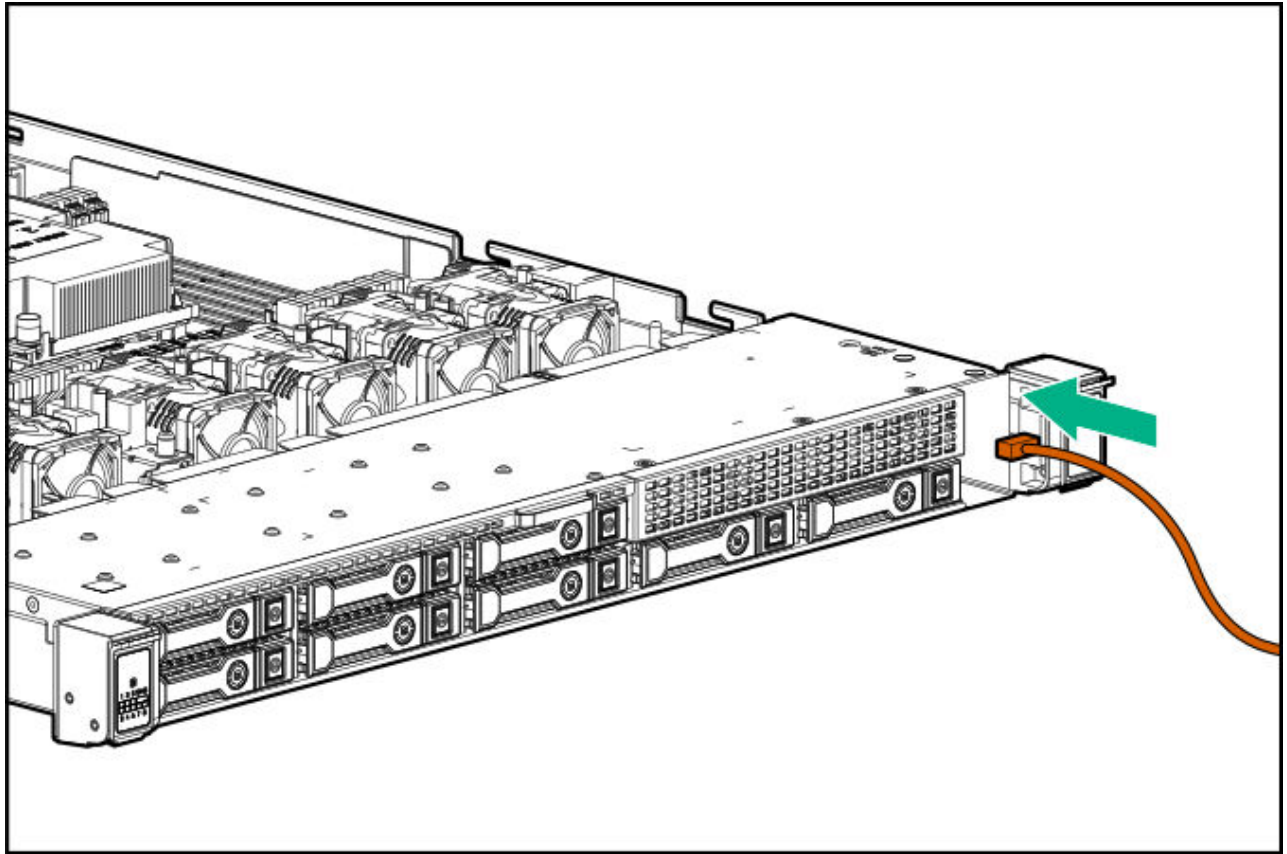

.0. Install the SID module into the front panel. Using a T-10 Torx screwdriver, secure the module to the chassis with the screws from the kit.

- 8 SFF

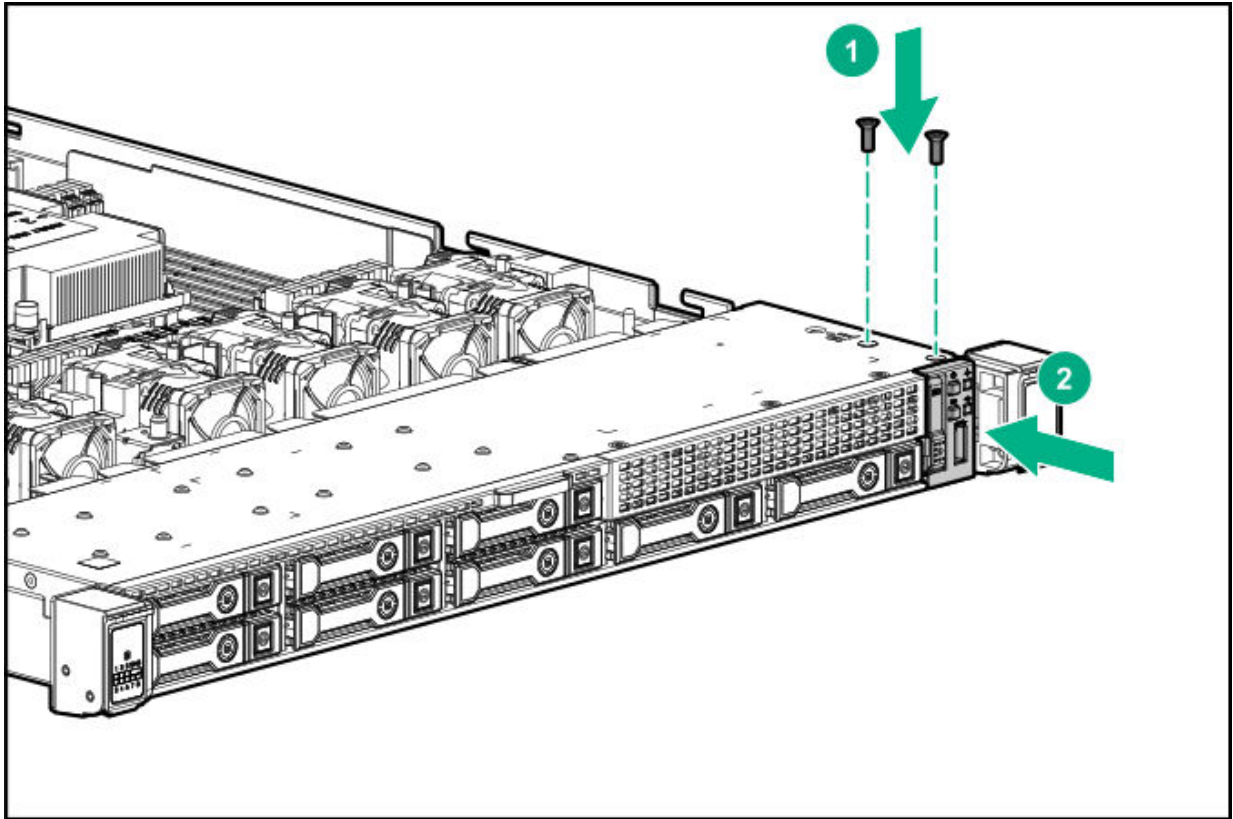

- 4 LFF

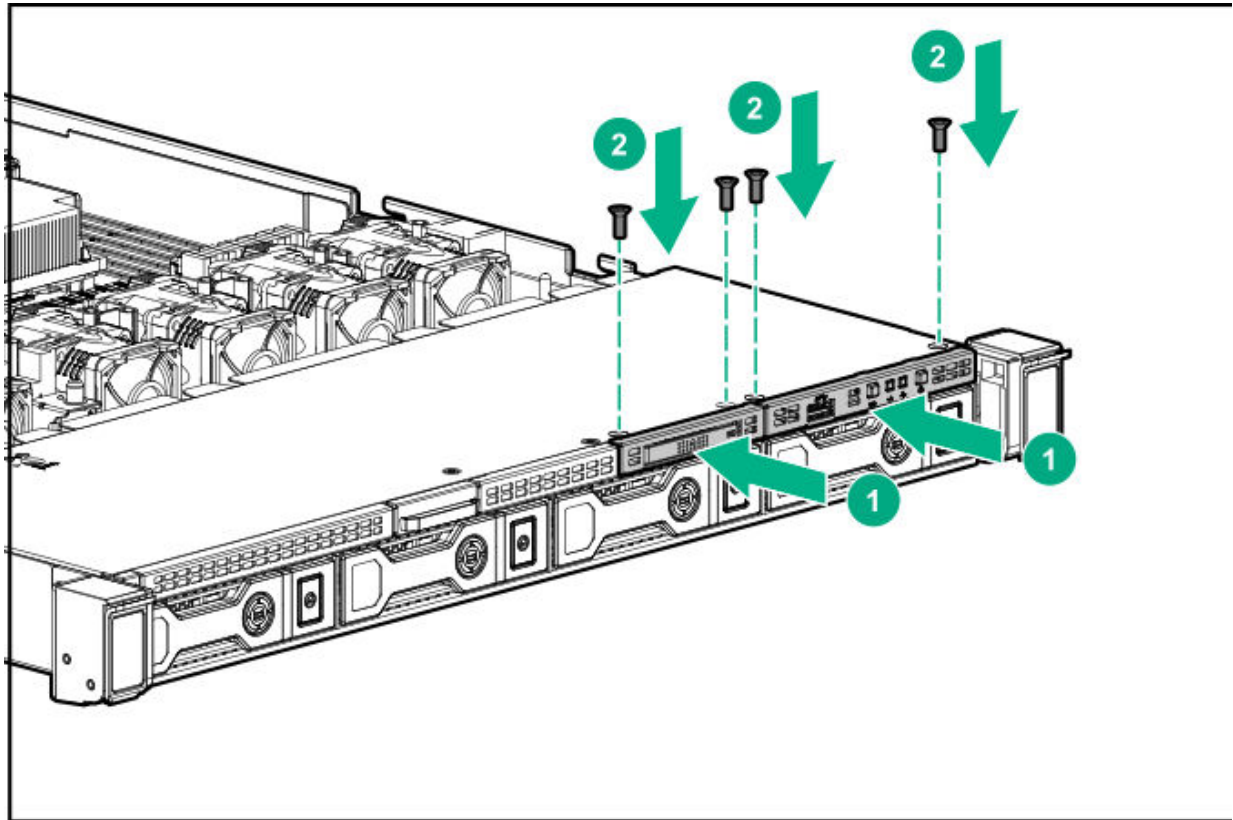

1. Connect the SID cables to the front power button/USB 3.0 connector on the system board.

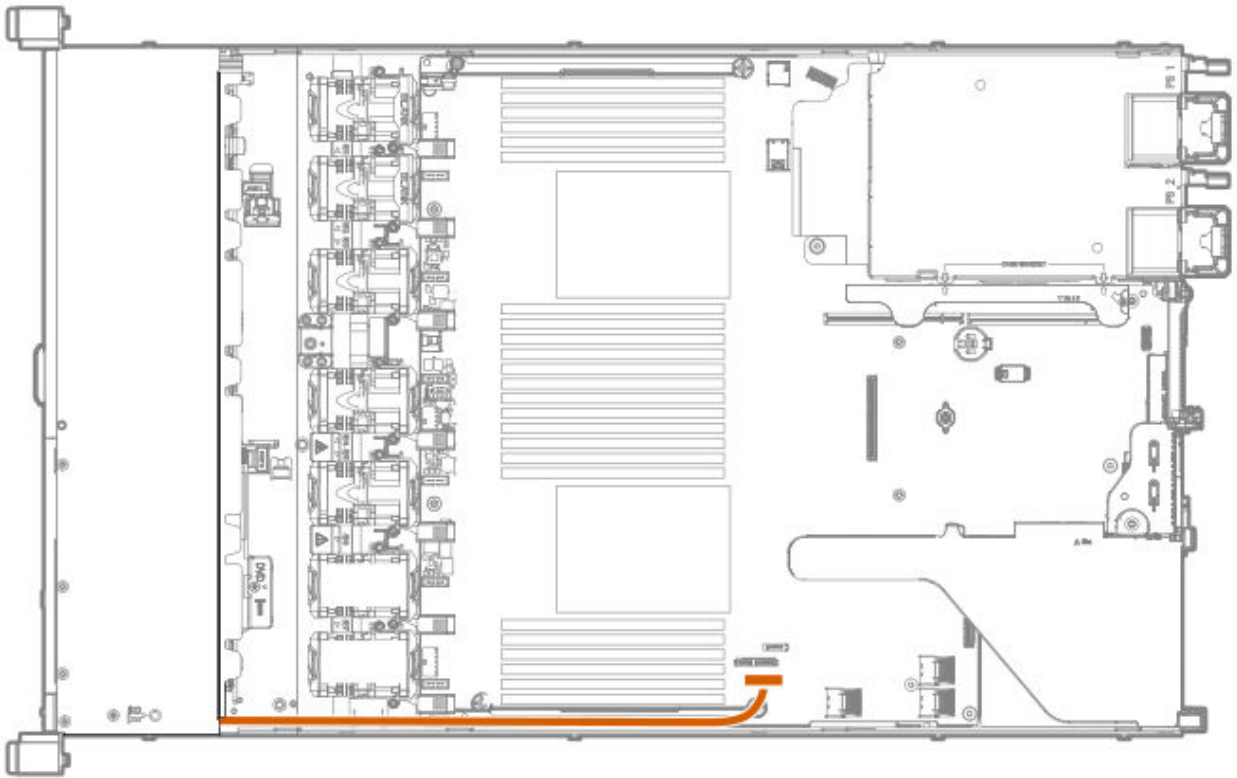

## Installing the 4 LFF display port/USB module

### Prerequisites

Before installing this option, be sure you have the following:

- The components included with the hardware option kit
- T-10 Torx screwdriver

### Procedure

1. Power down the server (Power down the server).
2. Remove all power:
  - a. Disconnect each power cord from the power source.
  - b. Disconnect each power cord from the server.

3. Do one of the following:
  - a. Extend the server from the rack (Extend the server from the rack).
  - b. Remove the server from the rack (Remove the server from the rack).
4. Remove the access panel (Remove the access panel).
5. Using a Torx T-10 screwdriver, remove the 4 LFF display port/USB blank.

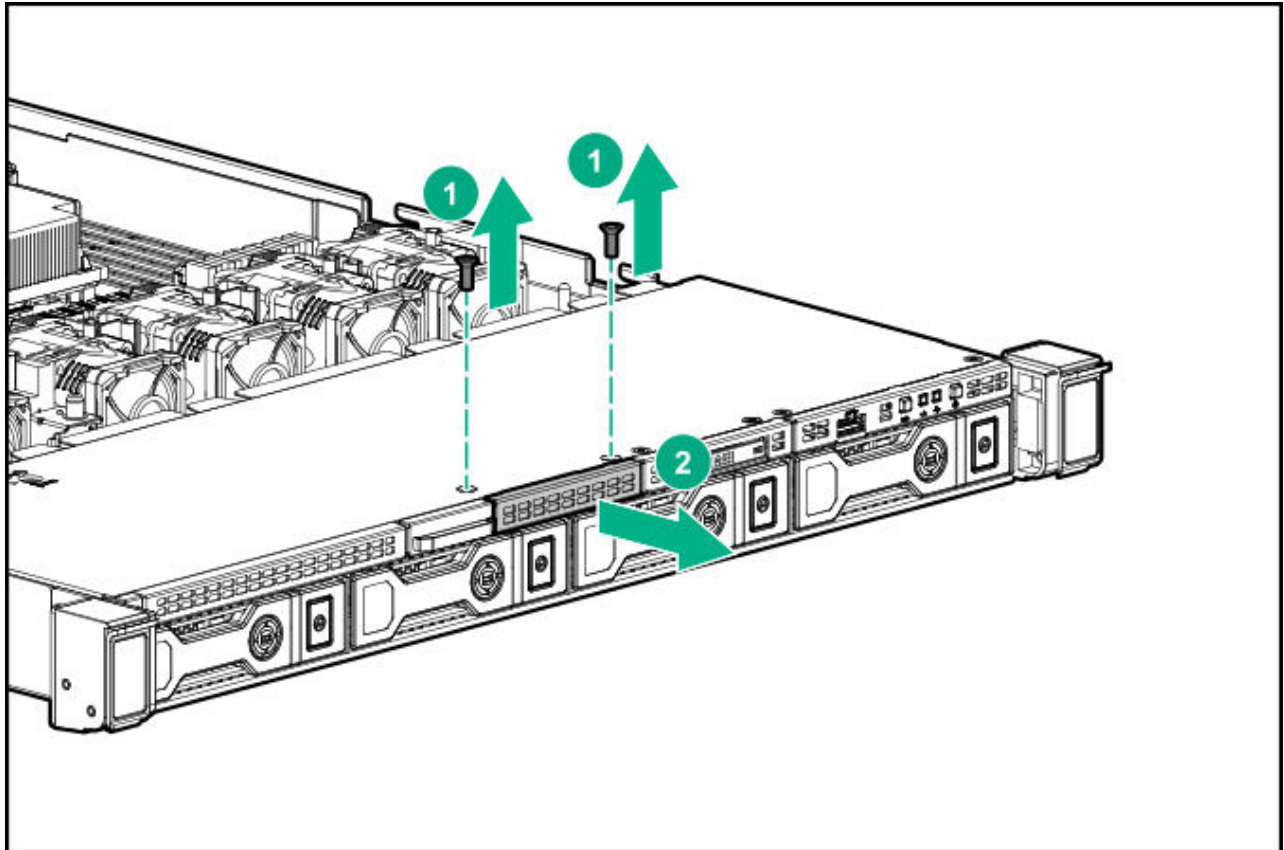

6. Install the 4 LFF display port/USB module.

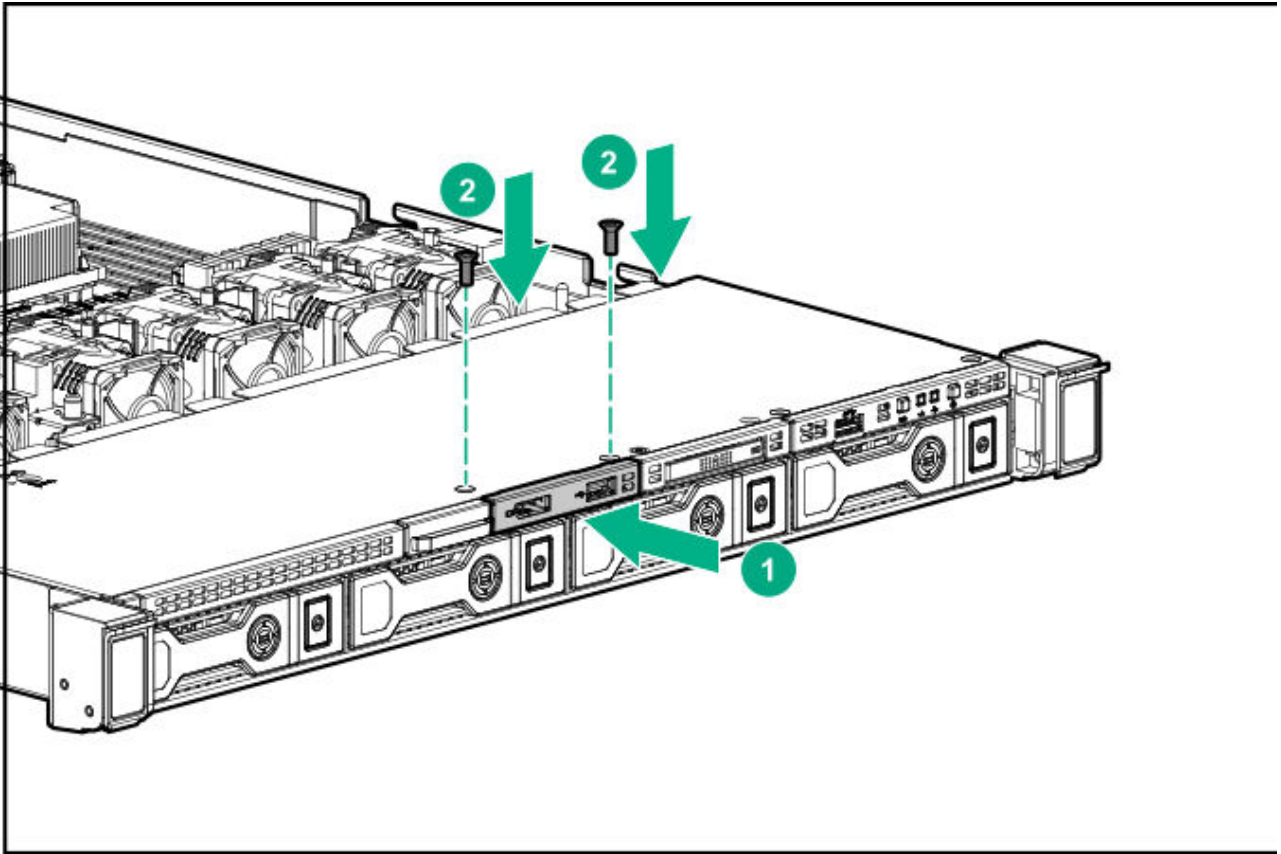

7. Route and connect the cable.

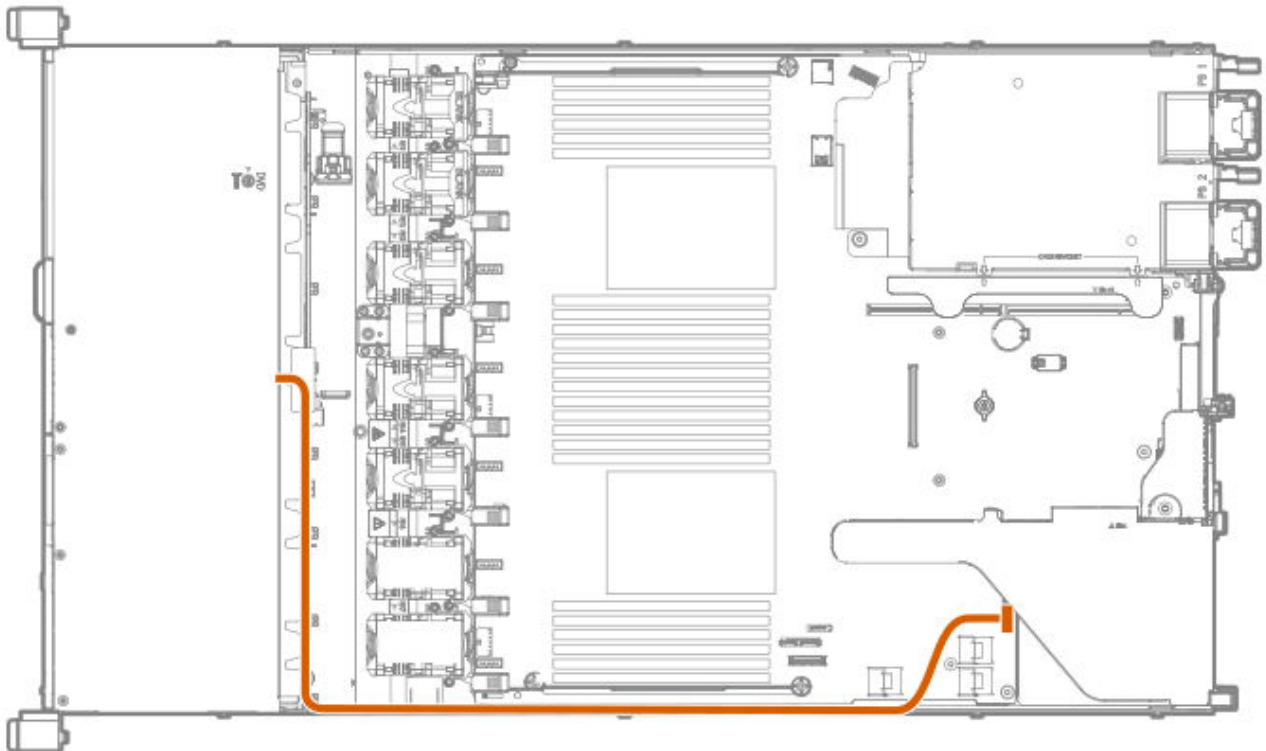

8. Install the access panel ([Install the access panel](#)).
9. Install the server in the rack.
10. Connect each power cord to the server.
  1. Connect each power cord to the power source.
  2. Power up the server ([Power up the server](#)).

## Installing the serial cable option

### Prerequisites

Before installing this option, be sure you have the following:

- The components included with the hardware option kit
- 5 mm socket

### Procedure

1. Observe the following alerts:



**WARNING:** To reduce the risk of personal injury from hot surfaces, allow the drives and the internal system components to cool before touching them.



**CAUTION:** To prevent damage to electrical components, properly ground the server before beginning any installation procedure. Improper grounding can cause electrostatic discharge.

2. Back up all server data.
3. Power down the server ([Power down the server](#)).
4. Remove all power:
  - a. Disconnect each power cord from the power source.
  - b. Disconnect each power cord from the server.
5. Do one of the following:

- a. Extend the server from the rack (Extend the server from the rack).
  - b. Remove the server from the rack (Remove the server from the rack).
6. Remove the access panel (Remove the access panel).
  7. Remove the serial cable blank.

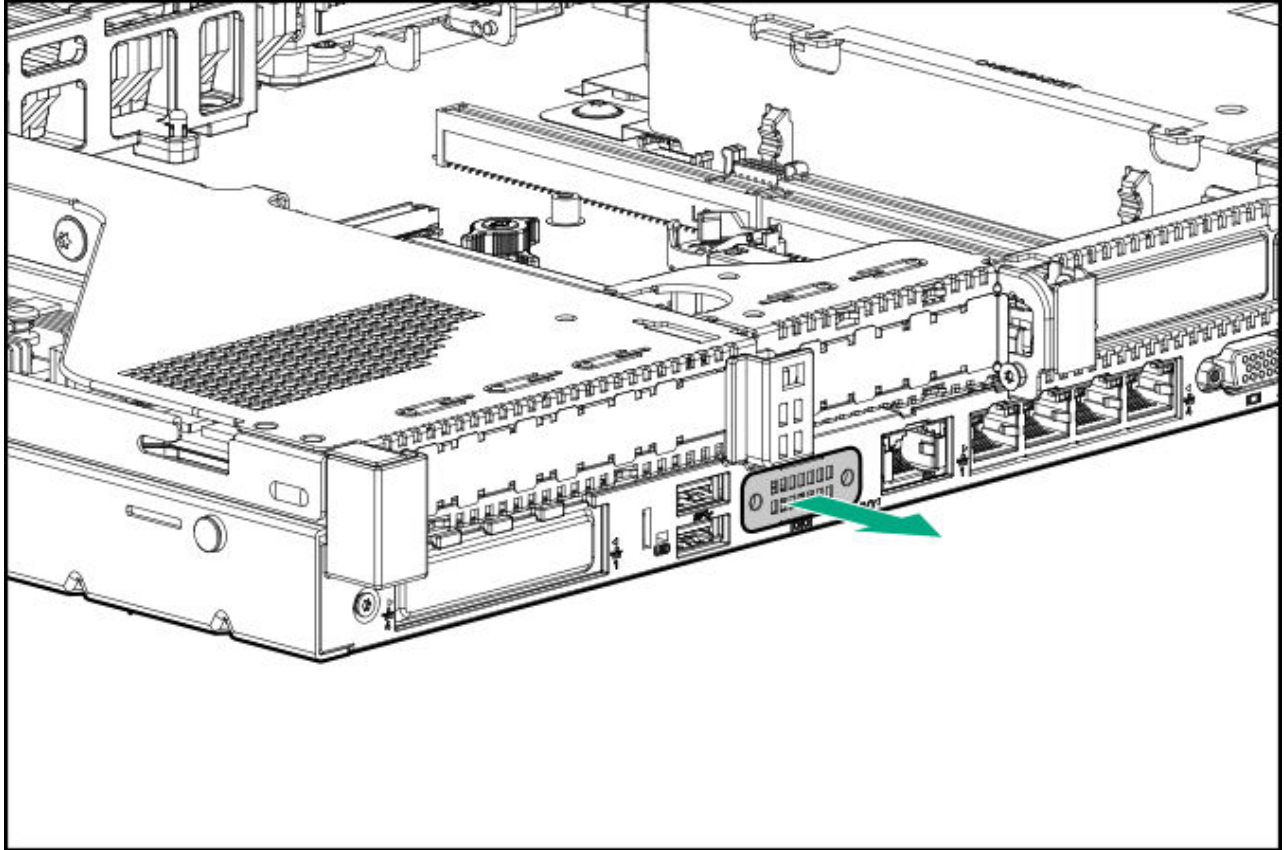

8. Connect the serial cable option, and then secure the cable with two T-10 screws. Then, remove the backing from the double-sided tape and press down where indicated.

A 5 mm socket is required for this step.

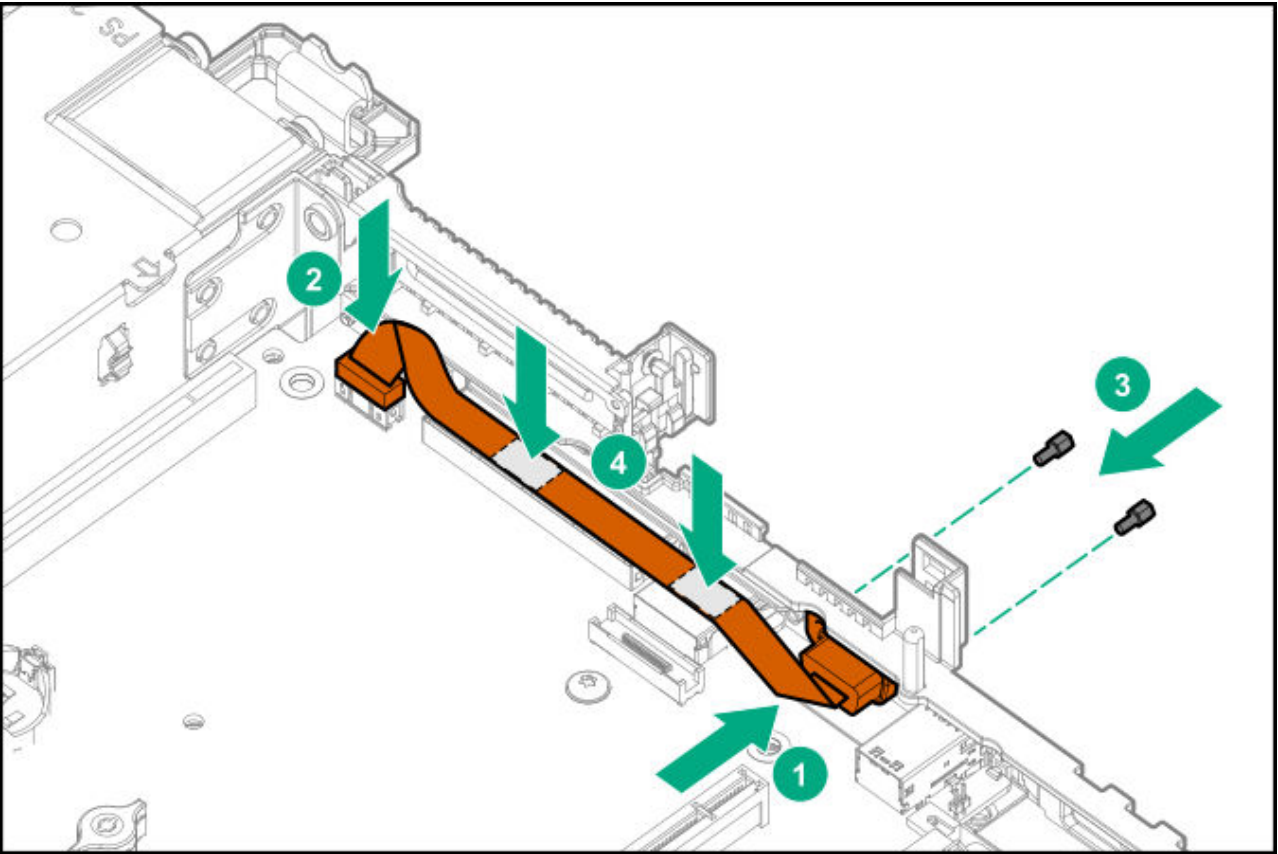

9. Install the access panel ([Install the access panel](#)).
0. Install the server in the rack.
- .1. Connect each power cord to the server.
- .2. Connect each power cord to the power source.
- .3. Power up the server ([Power up the server](#)).

## Installing the Chassis Intrusion Detection switch option

### Prerequisites

Before installing this option, be sure you have the following:

- The components included with the hardware option kit
- T-15 Torx screwdriver

## Procedure

1. Power down the server (Power down the server).
2. Remove all power:
  - a. Disconnect each power cord from the power source.
  - b. Disconnect each power cord from the server.
3. Do one of the following:
  - a. Extend the server from the rack (Extend the server from the rack).
  - b. Remove the server from the rack (Remove the server from the rack).
4. Remove the access panel (Remove the access panel).
5. Use a T-15 Torx screwdriver to remove the left DIMM guard from the system board.

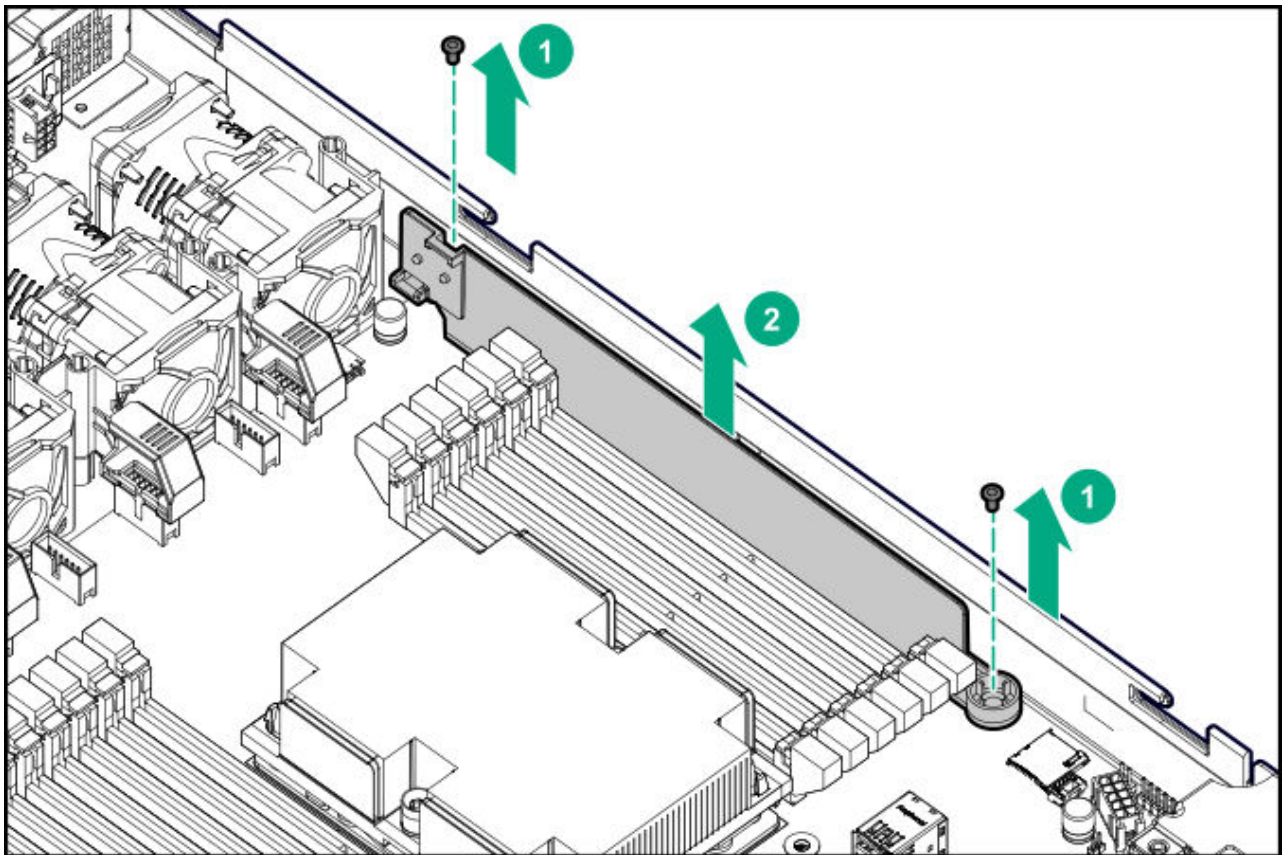

6. Assemble the connector/cable harness pin openings to the alignment pegs on the DIMM guard.
7. Install the plastic cover on the DIMM guard.

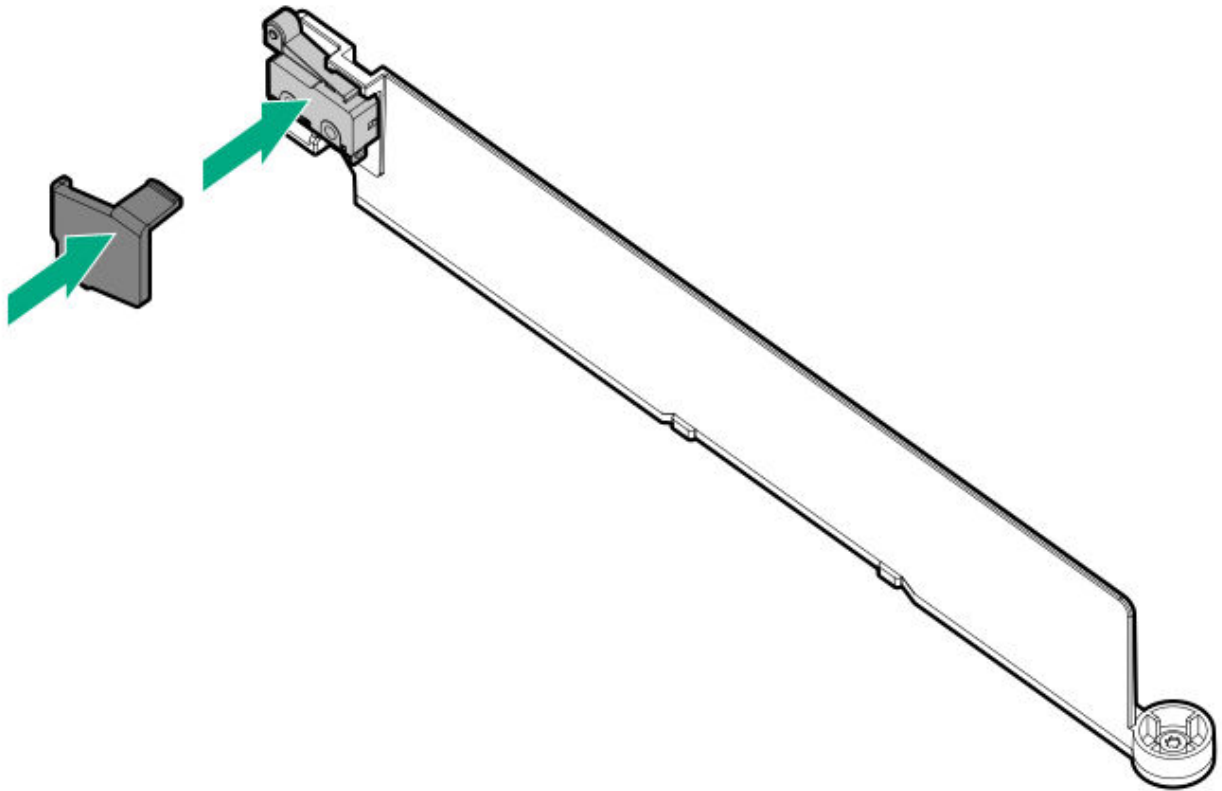

8. Use a T-15 Torx screwdriver to install the DIMM guard, and then connect the cable to the system board.

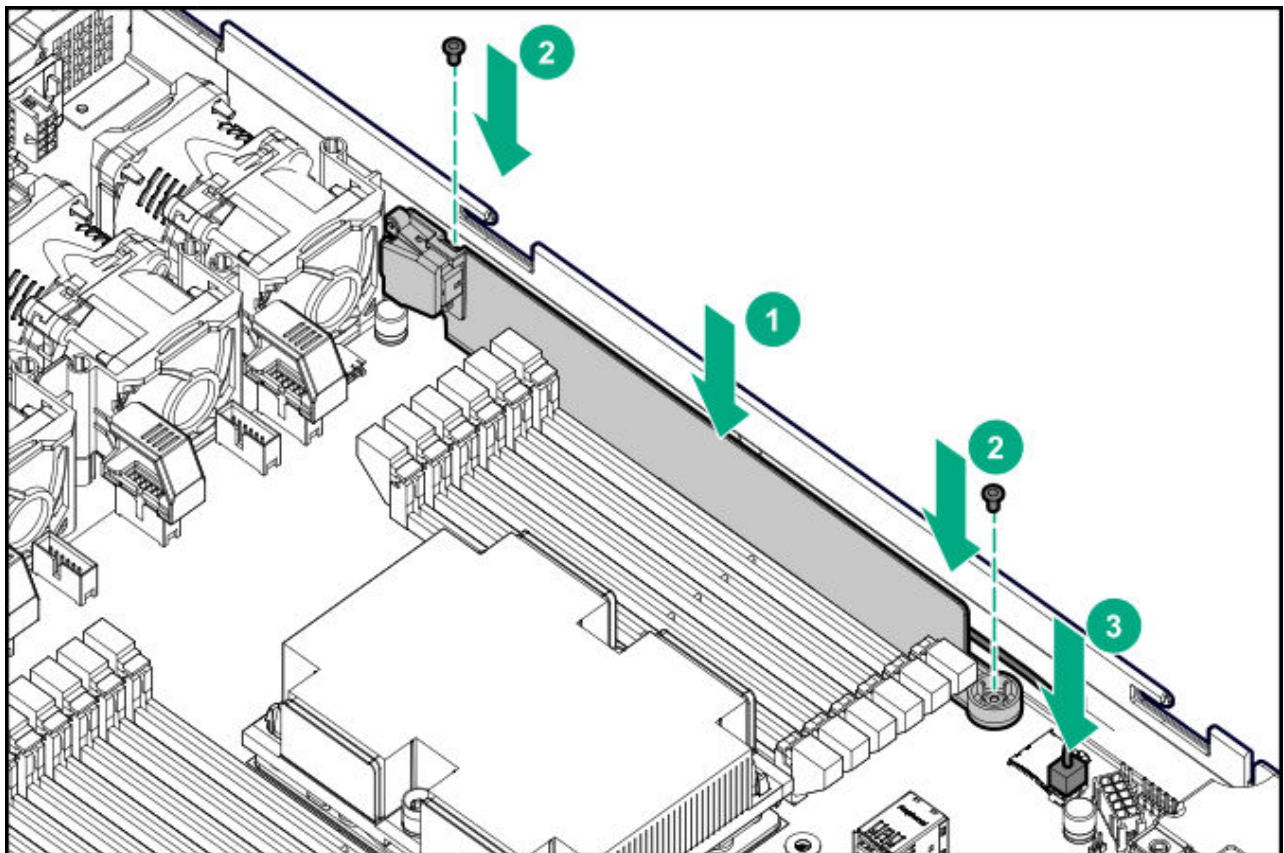

9. Install the access panel (Install the access panel).
- .0. Install the server in the rack.
- .1. Connect each power cord to the server.
- .2. Connect each power cord to the power source.
- .3. Power up the server (Power up the server).

## Installing the FlexibleLOM option

### Prerequisites

Before installing this option, be sure that you have the following:

- The components included with the hardware option kit
- T-10 Torx screwdriver

### Procedure

1. Power down the server.
2. Remove all power:
  - a. Disconnect each power cord from the power source.
  - b. Disconnect each power cord from the server.
3. Do one of the following:
  - Extend the server from the rack.
  - Remove the server from the rack.
4. Remove the access panel.
5. Use a T-10 Torx screwdriver to remove the FlexibleLOM slot blank.

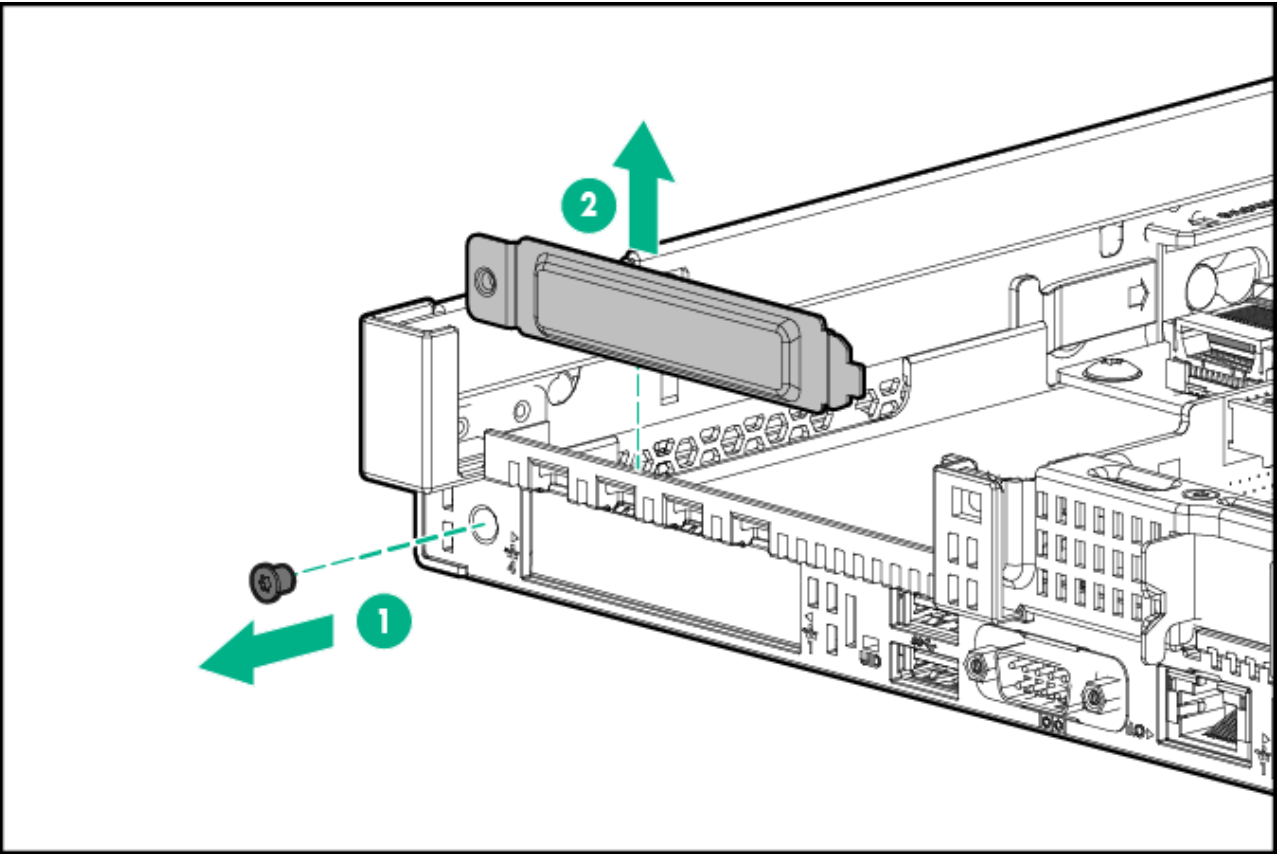

6. Install the FlexibleLOM:
  - a. Firmly seat the FlexibleLOM in the slot.
  - b. Tighten the thumbscrew.

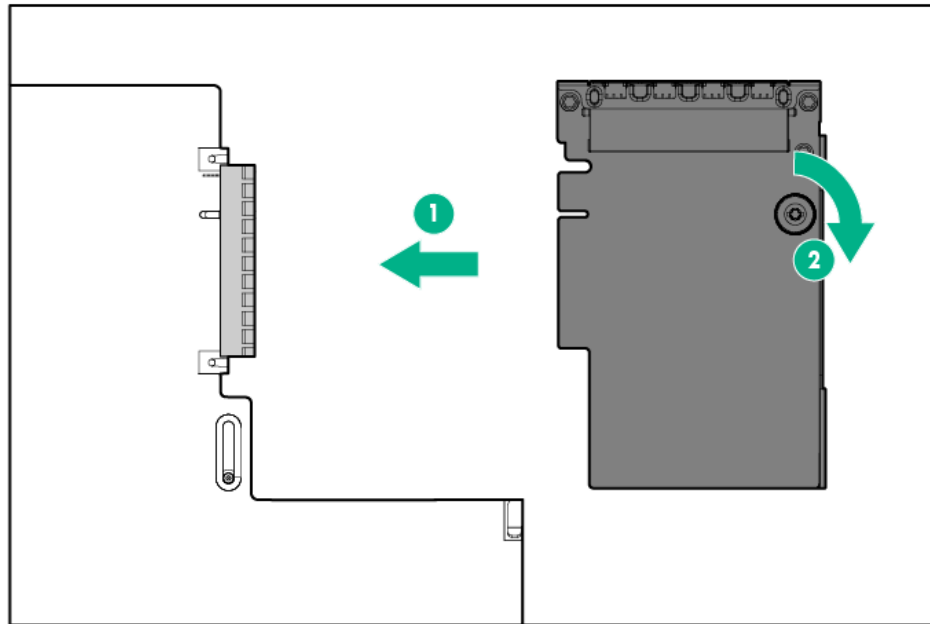

7. Install the access panel.
8. Slide the server into the rack.
9. Connect the LAN segment cables.
10. Connect each power cord to the server.
11. Connect each power cord to the power source.
12. Power up the server (Power up the server).

## Installing the Pensando DSP DSC-25 2p SFP28 card with the iLO Sideband ALOM Module

### Prerequisites

Before installing this option, be sure you have the following:

- The components included with the hardware option kit.

- T-10 Torx screwdriver.

### About this task

Pensando DSP iLO Sideband ALOM Module requires that the accompanying Smart I/O card (such as the Pensando DSP DSC-25 2p SFP28 card) be installed on slot 1 of the primary PCIe riser cage.

### Procedure

1. Observe the following alerts:



**WARNING:** To reduce the risk of personal injury from hot surfaces, allow the drives and the internal system components to cool before touching them.



**CAUTION:**

A discharge of static electricity from a finger or other conductor might damage system boards or other static-sensitive devices. To prevent damage, observe antistatic precautions.



**CAUTION:**

To prevent improper cooling and thermal damage, do not operate the server unless all PCI slots have either an expansion slot cover or an expansion card installed.

2. Power down the server.
3. Disconnect each power cord from the server.
4. Disconnect each power cord from the power source.
5. Extend the server from the rack.
6. Remove the server from the rack.
7. Remove the access panel.
8. Remove the primary PCIe riser cage to access the slot on the system board in which to install the ALOM module.

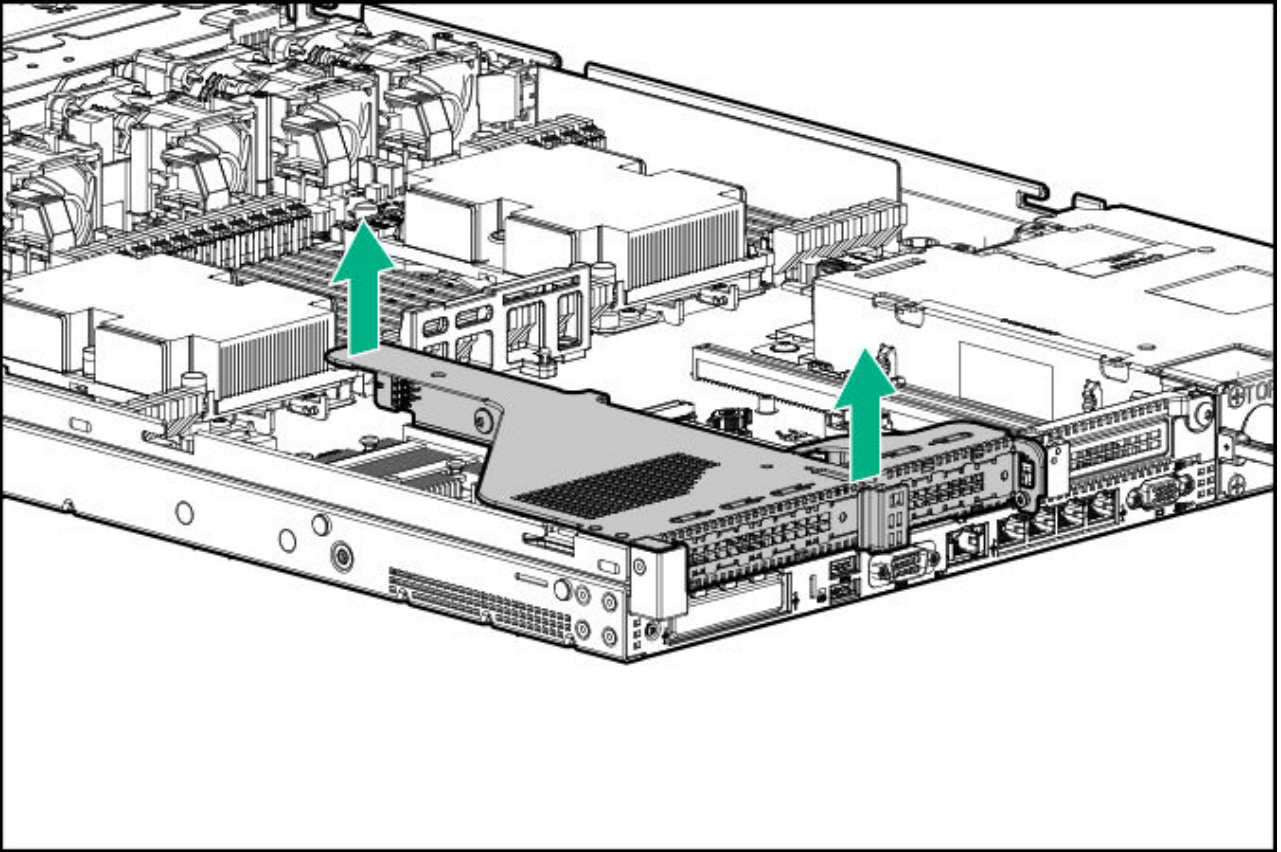

9. Install the Pensando DSP iLO Sideband ALOM Module into the FlexibleLOM adapter connector on the system board.

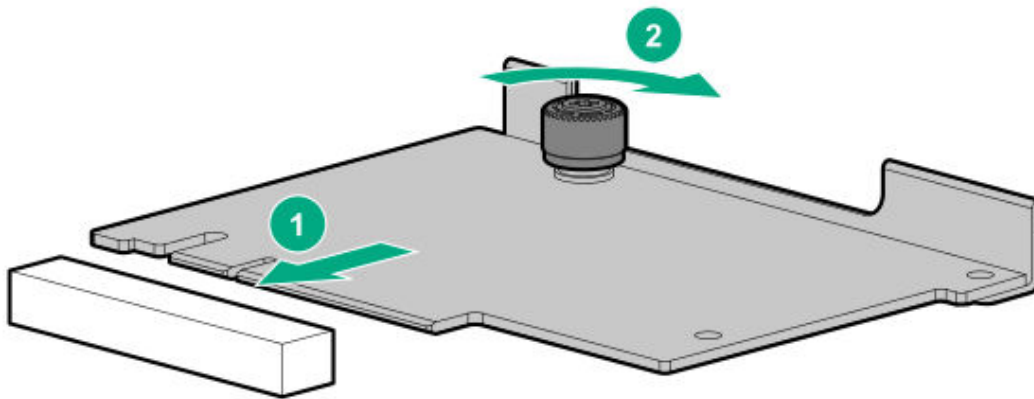

0. Remove the shipping cap from the auxiliary cable.
1. Connect the auxiliary cable to the iLO Sideband ALOM Module:

- a. Align the connector keying posts to the ALOM module.
- b. Secure the auxiliary cable to the ALOM module using the thumbscrew.



**CAUTION:**

Do not over torque the screw.



**CAUTION:**

Do not use a screwdriver to tighten the screw.



**CAUTION:**

Do not twist the cable service loop during installation.

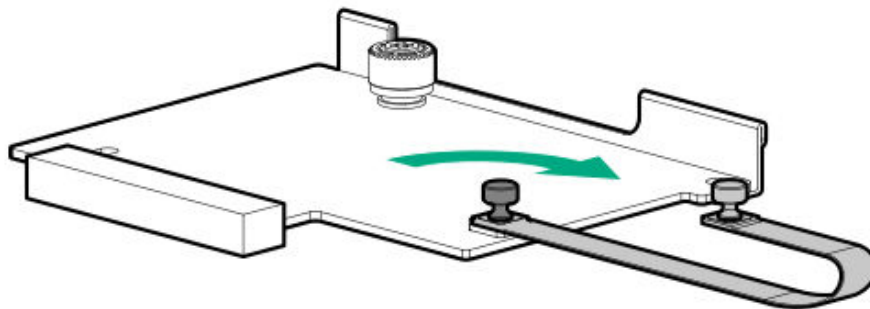

- .2. Remove the PCIe blank from slot 1 on the primary riser cage.

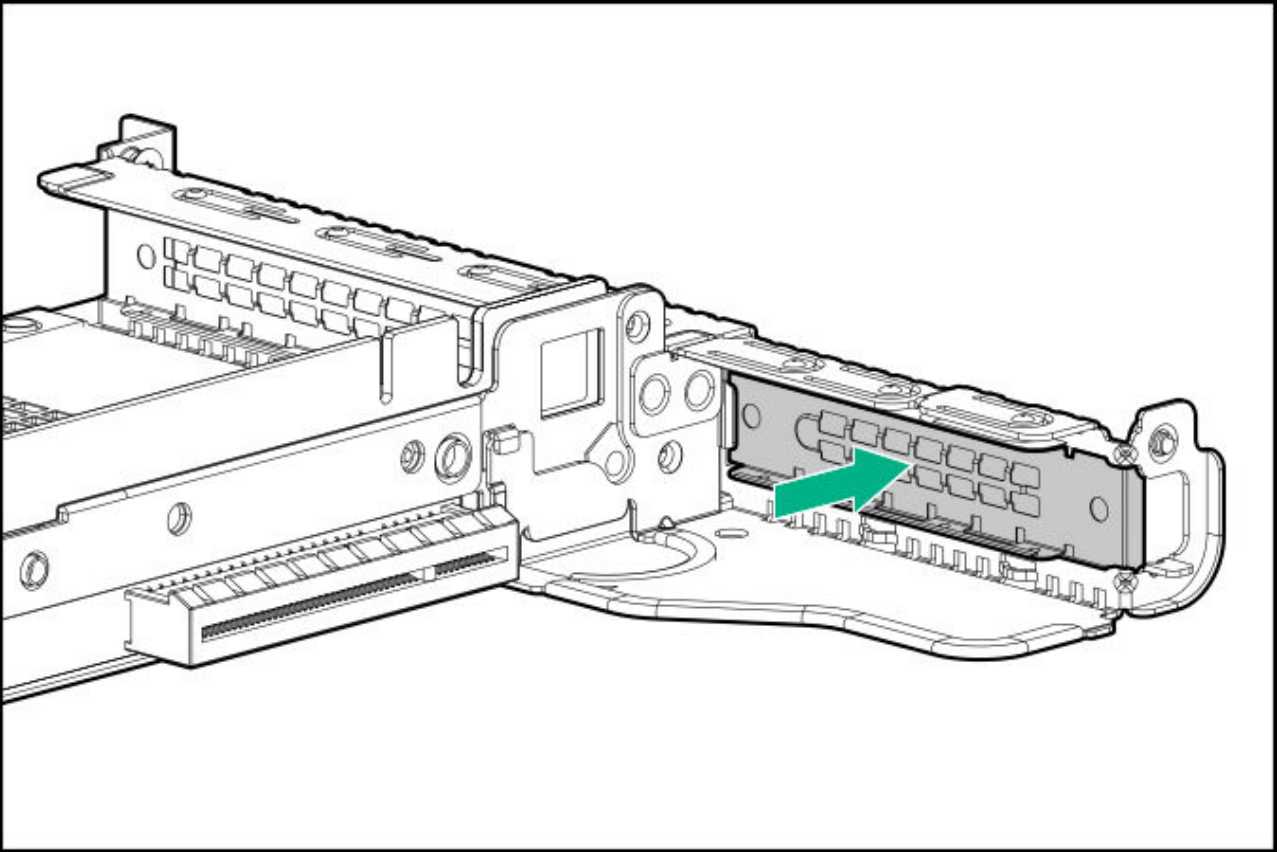

3. Install the DSC-25 card into the PCIe slot.

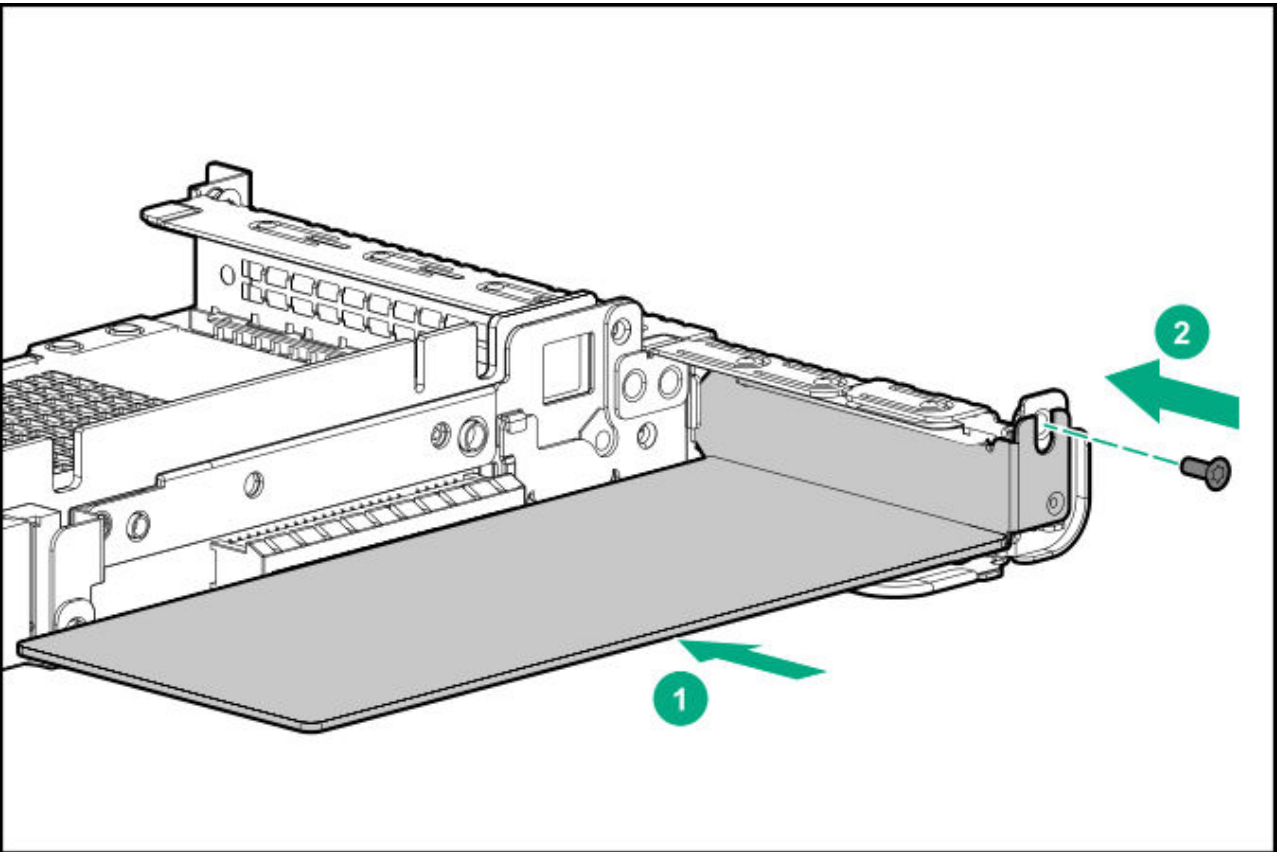

- .4. Install the PCIe riser cage into the server.

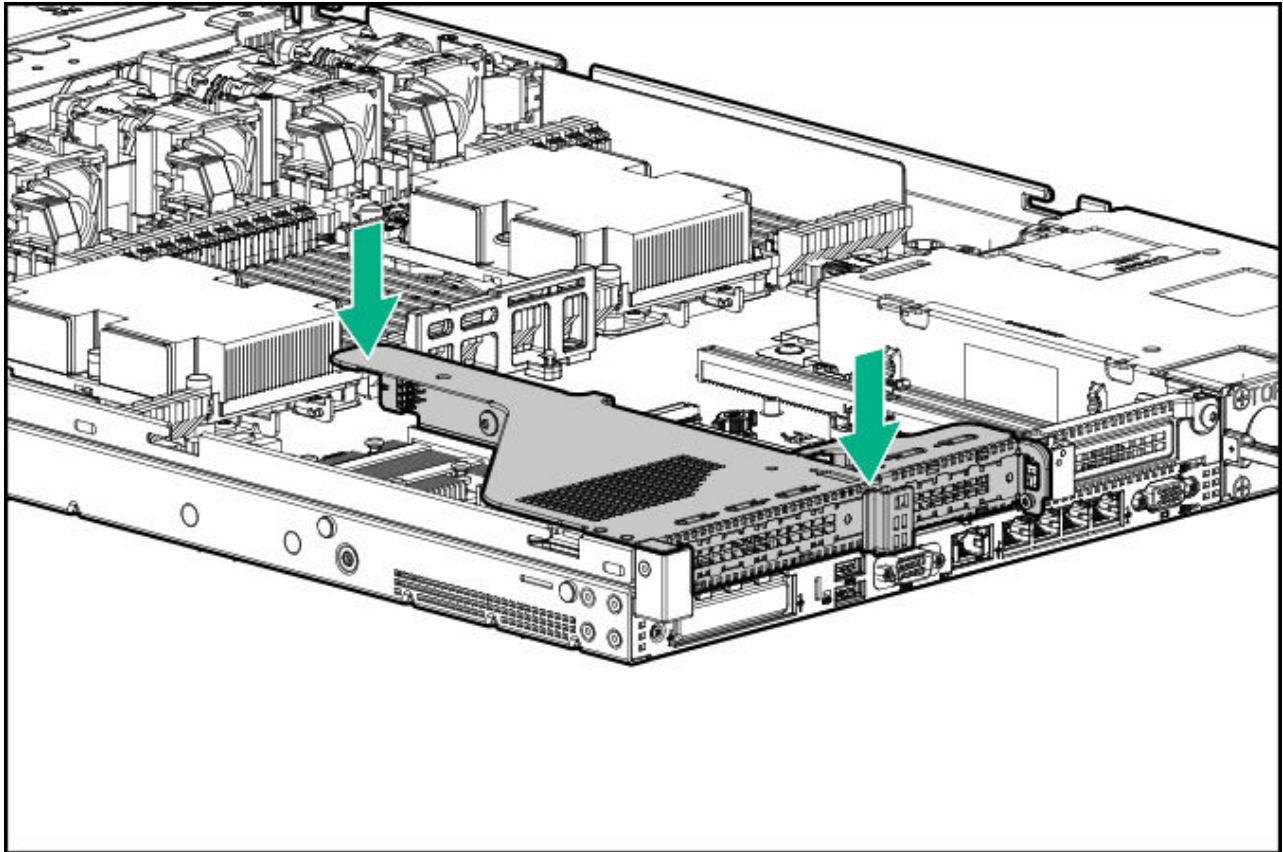

- .5. Apply the label that reads, "Card with cable attached. Remove riser with care" to the top of the PCIe riser cage.



**CAUTION:**

Be sure not to cover any other label or perforations on the PCIe riser cage when applying the label.

- .6. Remove the shipping cap from the auxiliary cable.
- .7. Connect the auxiliary cable to the DSC-25 card:
  - a. Align the connector keying posts to the DSC-25 card.

b. Secure the auxiliary cable to the DSC-25 card using the thumbscrew.



**CAUTION:**

Do not over torque the screw.



**CAUTION:**

Do not use a screwdriver to tighten the screw.



**CAUTION:**

Do not twist the cable service loop during installation.



**NOTE:**

The PCIe riser cage is not shown in this illustration for clarity purposes.

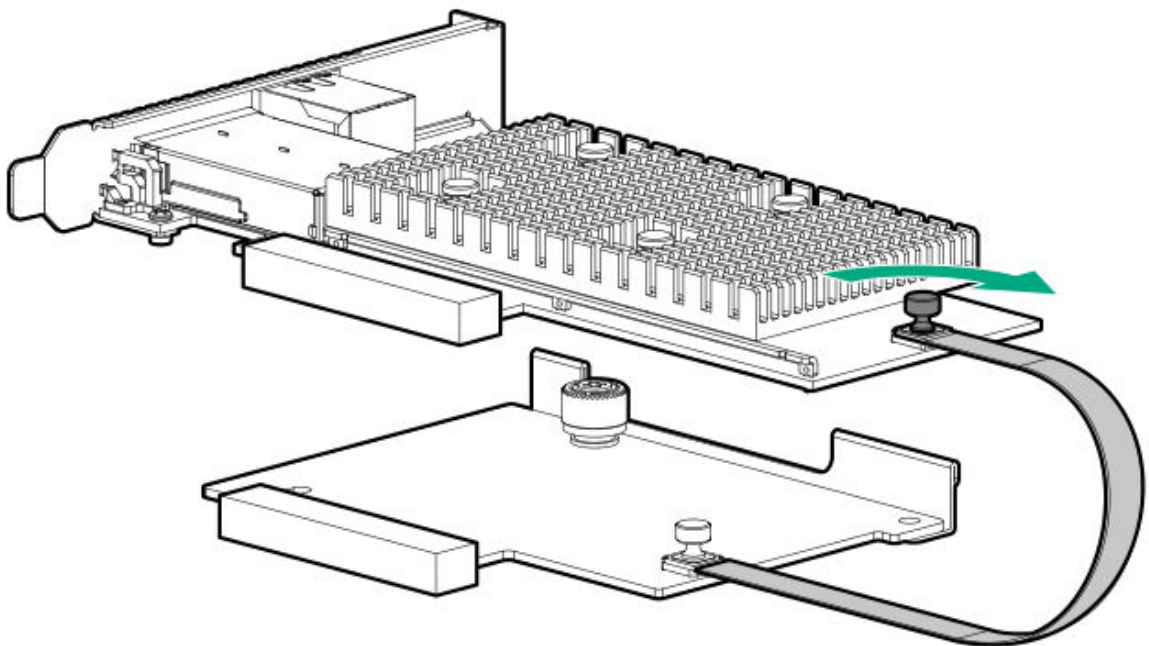

.8. Install the access panel.

.9. Install the server in the rack.

!0. Connect each power cord to the server.

1. Connect each power cord to the power source.
2. [Power up the server.](#)
3. Admit the new card to the Pensando Policy and Services Manager (PSM).

For more information, see the PSM Enterprise Edition User Guide.

## Results

The installation is complete.

# Installing the HPE NS204i-p Gen10 Plus Boot Device option

## Prerequisites

Before beginning installation, ensure that the server is updated with the latest operating system firmware and drivers.

Before installing this option, be sure you have the following:

- The components included with the hardware option kit.
- T-10 Torx screwdriver.

## Procedure

### Installing drives onto the boot device

1. Remove the liner from the thermal interface pad.

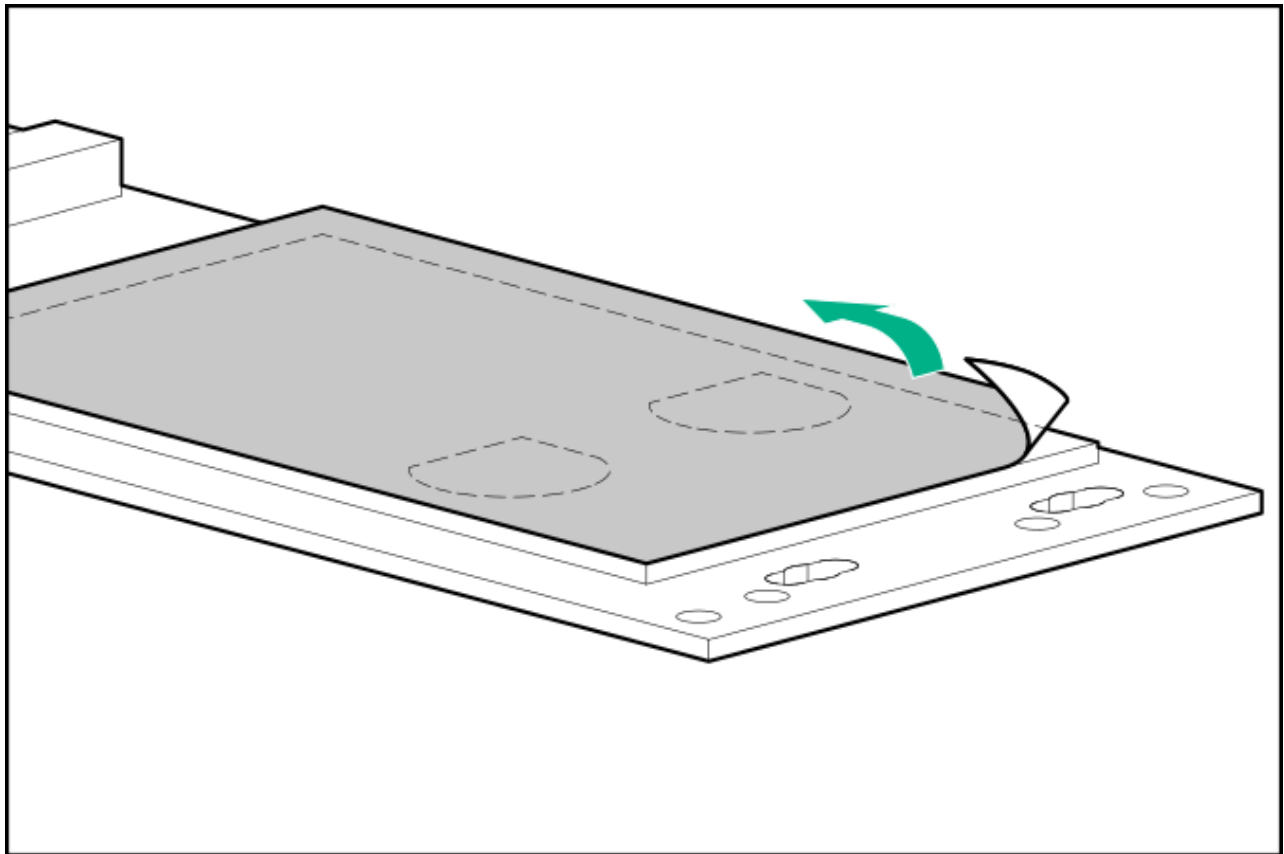

2. Install the drives.

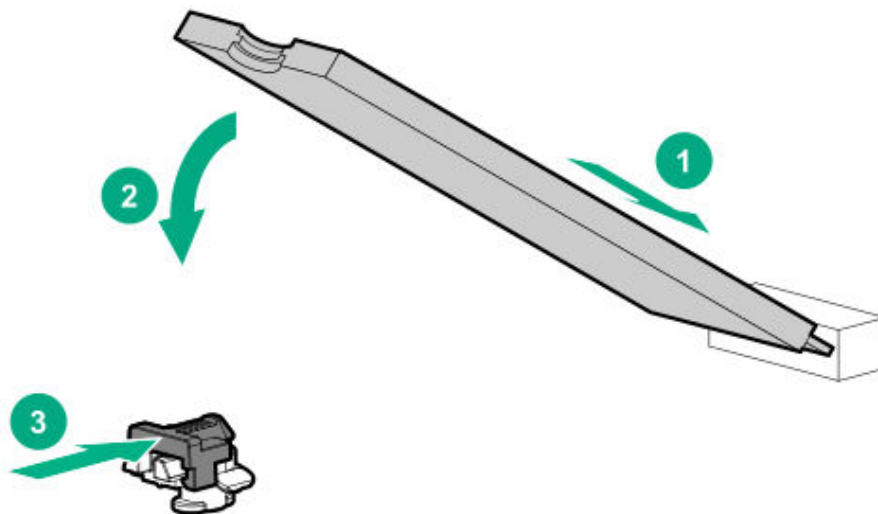

### Installing the boot device

3. Power down the server.
4. Remove all power:

- a. Disconnect each power cord from the power source.
- b. Disconnect each power cord from the server.
5. Extend the server from the rack.
6. Remove the server from the rack.
7. Place the server on a flat, level work surface.
8. Remove the access panel.
9. Select an available PCIe expansion slot that is x8 physical size and x4 electrical.
0. Remove the riser cage (Remove the primary PCI riser cage or Remove the secondary PCI riser cage).
- .1. Remove the expansion slot cover.  
Save the retaining screw, if one is present.
- .2. Install the boot device.

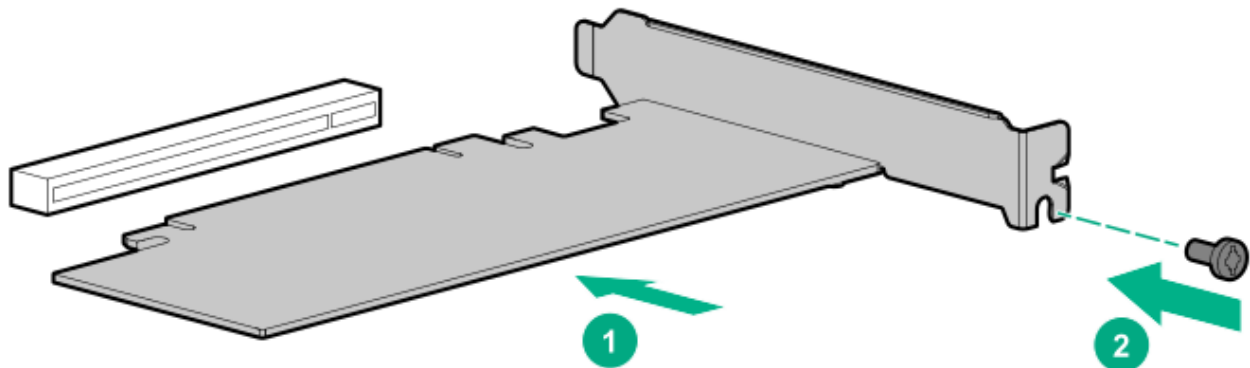

- .3. Install any components that were removed to access the expansion slot.
- .4. Install the access panel.
- .5. Install the server in the rack.
- .6. Connect each power cord to the server.
- .7. Connect each power cord to the power source.
- .8. Power up the server.

### **Deploying an operating system**

- .9. Deploy a supported operating system to the boot device drive.

For more information, see the product QuickSpecs (<https://www.hpe.com/info/qs>).

After the OS installation completes, the system automatically copies the operating system to the second, mirrored drive on the boot device.

!0. Proceed with normal system setup and operation.

## Energy pack options

Hewlett Packard Enterprise offers two centralized backup power source options to back up write cache content on the controllers in case of an unplanned server power outage.

- [HPE Smart Storage Battery](#)
- [HPE Smart Storage Hybrid Capacitor](#)



### **IMPORTANT:**

The HPE Smart Storage Hybrid Capacitor is only supported on Gen10 and later servers.

One energy pack option can support multiple devices. An energy pack option is required for 900 series controllers. Once installed, the status of the energy pack displays in HPE iLO. For more information, see the HPE iLO user guide on the [Hewlett Packard Enterprise website](#).

### Subtopics

[HPE Smart Storage Battery](#)

[HPE Smart Storage Hybrid Capacitor](#)

[Minimum firmware versions](#)

[Energy pack option configurations](#)

## HPE Smart Storage Battery

The HPE Smart Storage Battery supports the following devices:

- HPE Smart Array SR controllers
- HPE Smart Array MR controllers

- NVDIMMs



**IMPORTANT:**

To support NVDIMMs, the HPE Smart Storage Battery must be installed.

A single 96W battery can support up to 24 devices.

After the battery is installed, it might take up to two hours to charge. Controller features requiring backup power are not re-enabled until the battery is capable of supporting the backup power.

This server supports the 96W HPE Smart Storage Battery with the 145mm cable.

## HPE Smart Storage Hybrid Capacitor

The HPE Smart Storage Hybrid Capacitor supports the following devices:

- HPE SR controllers
- HPE MR controllers



**IMPORTANT:**

NVDIMMs are only supported by the HPE Smart Storage Battery.

The capacitor pack can support up to two devices.

This server supports the HPE Smart Storage Hybrid Capacitor with the 145 mm cable.

Before installing the HPE Smart Storage Hybrid Capacitor, verify that the system BIOS meets the minimum firmware requirements to support the capacitor pack.



**IMPORTANT:**

If the system BIOS or controller firmware is older than the minimum recommended firmware versions, the capacitor pack will only support one device.

The capacitor pack is fully charged after the system boots.

## Minimum firmware versions

<b>Product</b>	<b>Minimum firmware version</b>
HPE ProLiant DL360 Gen10 Server system ROM	2.00
HPE Smart Array SR controllers	1.90
HPE Smart Array MR controllers	24.23.0-0041

## Energy pack option configurations

In the HPE ProLiant DL360 Gen10 Server , an energy pack can be installed in two different orientations, depending on configuration:

- [Installing an energy pack in 8 SFF and 4 LFF configurations](#)
- [Installing an energy pack in the 10 SFF SAS/SATA/NVMe Combo backplane configuration](#)

### Subtopics

[\*\*Installing an energy pack in the 10 SFF SAS/SATA/NVMe Combo backplane configuration\*\*](#)

[\*\*Installing an energy pack in 8 SFF and 4 LFF configurations\*\*](#)

## Installing an energy pack in the 10 SFF SAS/SATA/NVMe Combo backplane configuration

### Prerequisites

The energy pack must be installed in this orientation when the 10 SFF SAS/SATA/NVMe Combo backplane is installed.

### Procedure

1. Power down the server ([Power down the server](#)).
2. Remove all power:
  - a. Disconnect each power cord from the power source.
  - b. Disconnect each power cord from the server.
3. Do one of the following:
  - a. [Extend the server from the rack](#).

- b. Remove the server from the rack.
- 4. Remove the access panel.
- 5. Remove the right retainer. Set aside.

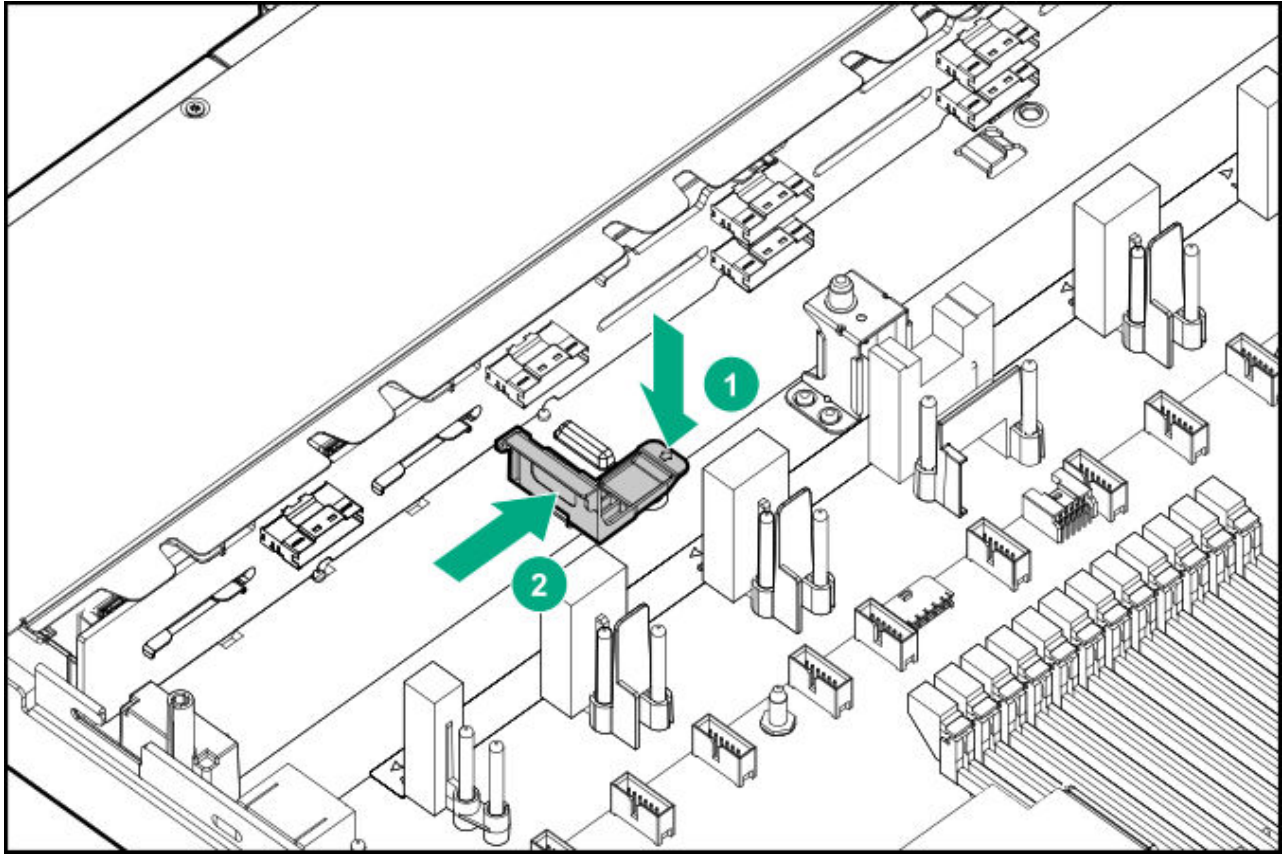

- 6. Slide the energy pack into the left retainer, and then install the right retainer.

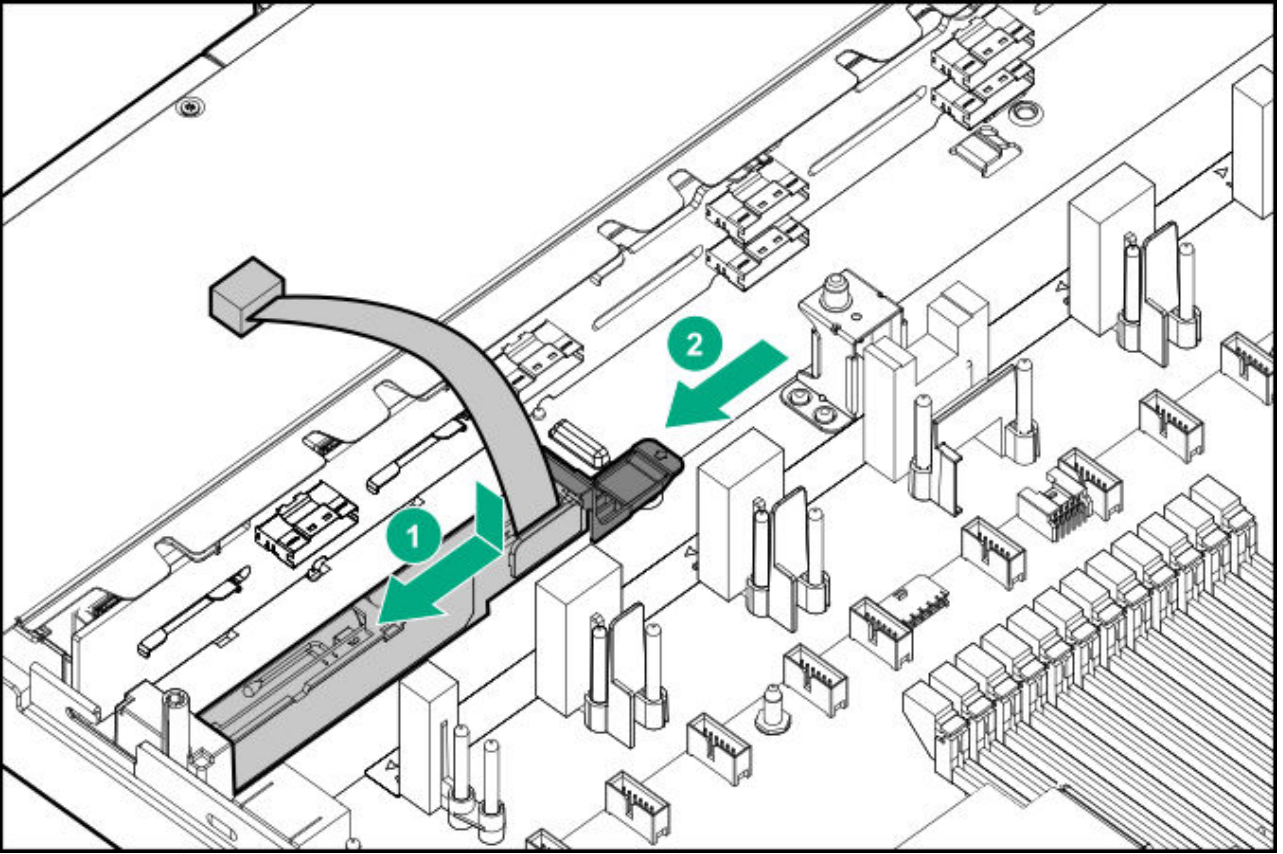

7. Connect the energy pack cable:
  - a. Remove the center fan baffle.

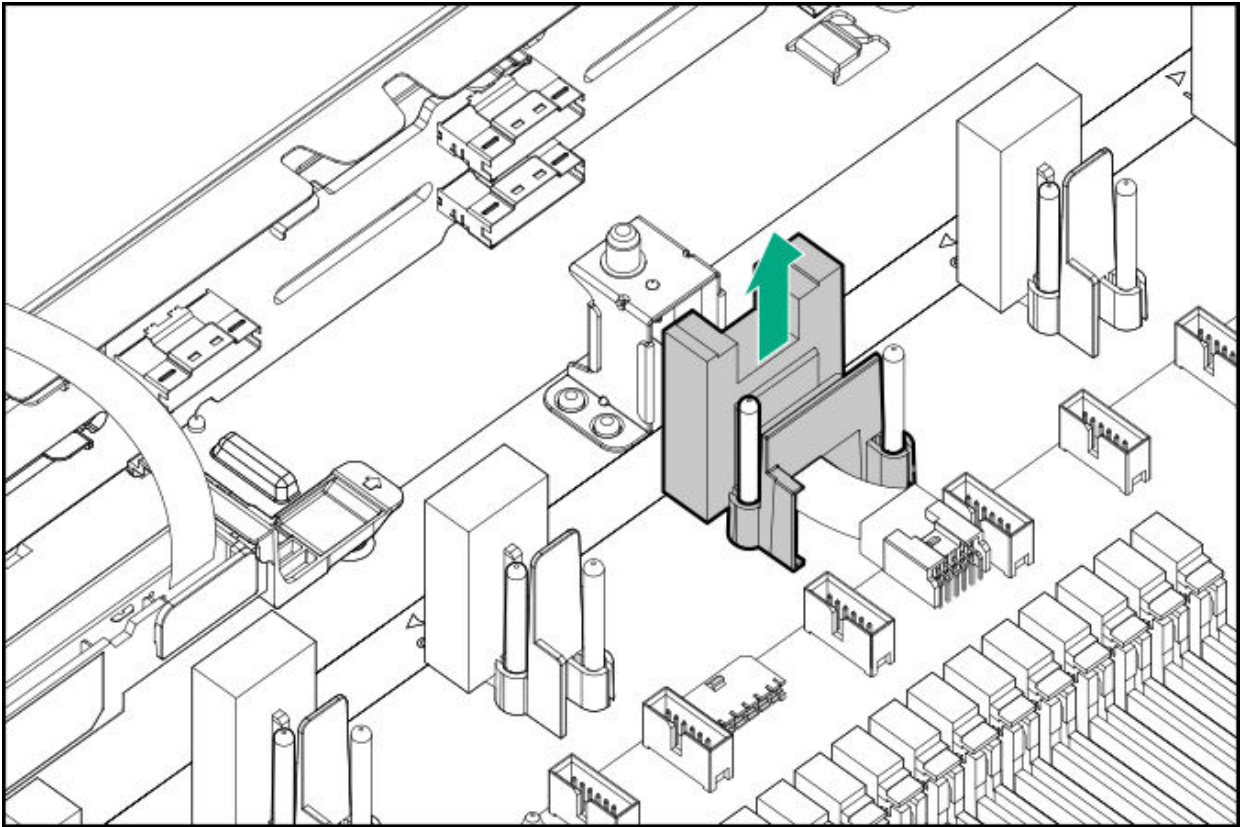

b. Connect the energy pack cable to the extender cable.

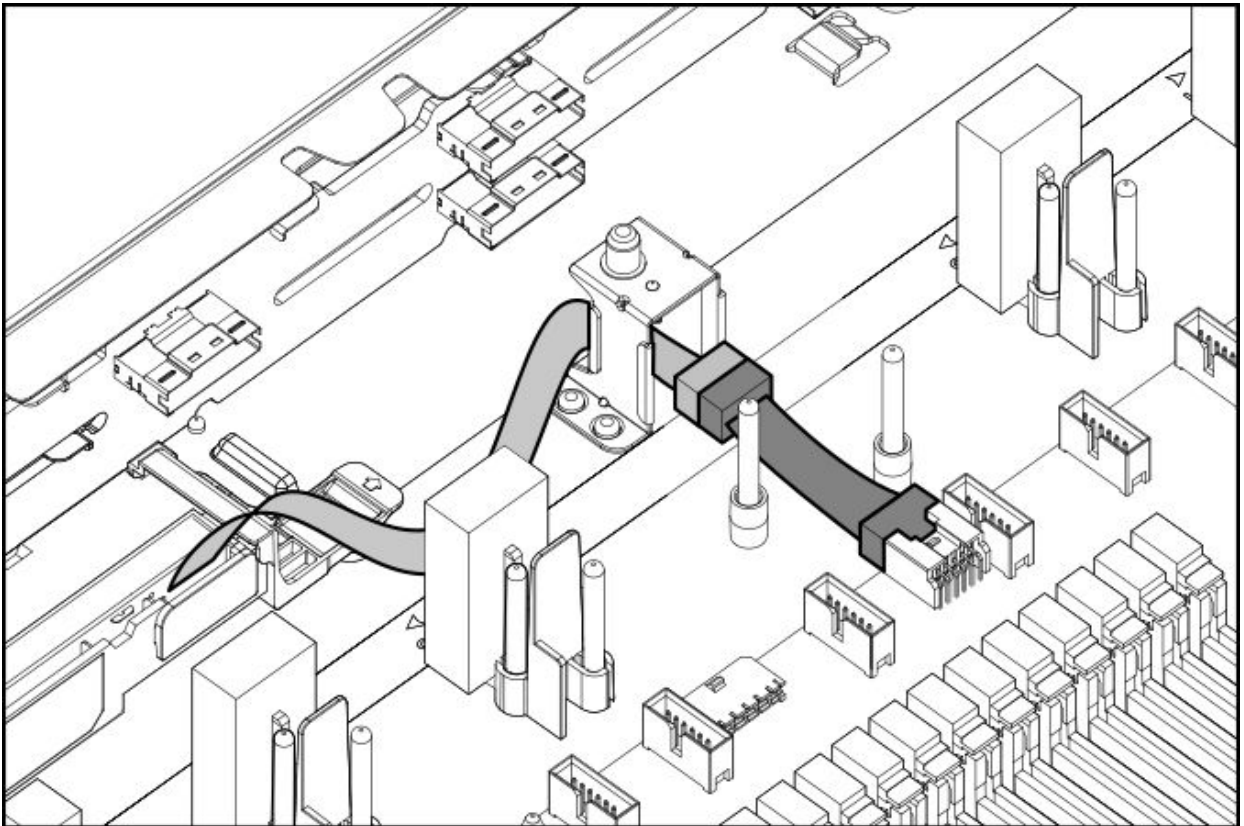



**IMPORTANT:**

To enable SmartCache or CacheCade in a P-class type-p Smart Array controller, you must:

- Connect the controller backup power cable to the controller backup power connector on the system or riser board.
- Connect the energy pack cable to the energy pack connector on the system board.

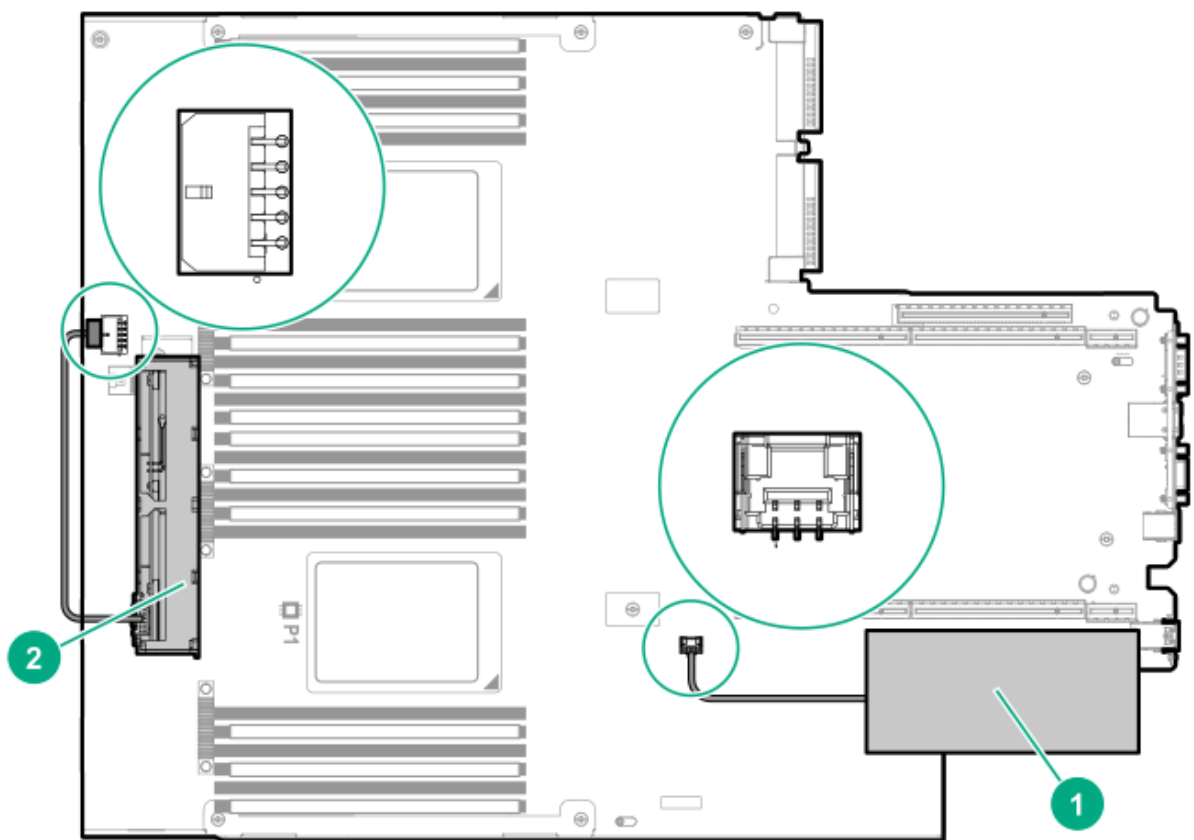

c. Install the center fan baffle.

8. Install the access panel ([Install the access panel](#)).
9. Install the server in the rack.
10. Connect each power cord to the server.
11. Connect each power cord to the power source.

- .2. Power up the server.

## Installing an energy pack in 8 SFF and 4 LFF configurations

### Prerequisites

Before installing this option, be sure you that have the components included with the hardware option kit.

### Procedure

1. Power down the server (Power down the server).
2. Remove all power:
  - a. Disconnect each power cord from the power source.
  - b. Disconnect each power cord from the server.
3. Do one of the following:
  - a. Extend the server from the rack.
  - b. Remove the server from the rack.
4. Remove the access panel.
5. Install the energy pack and connect the energy pack cable.

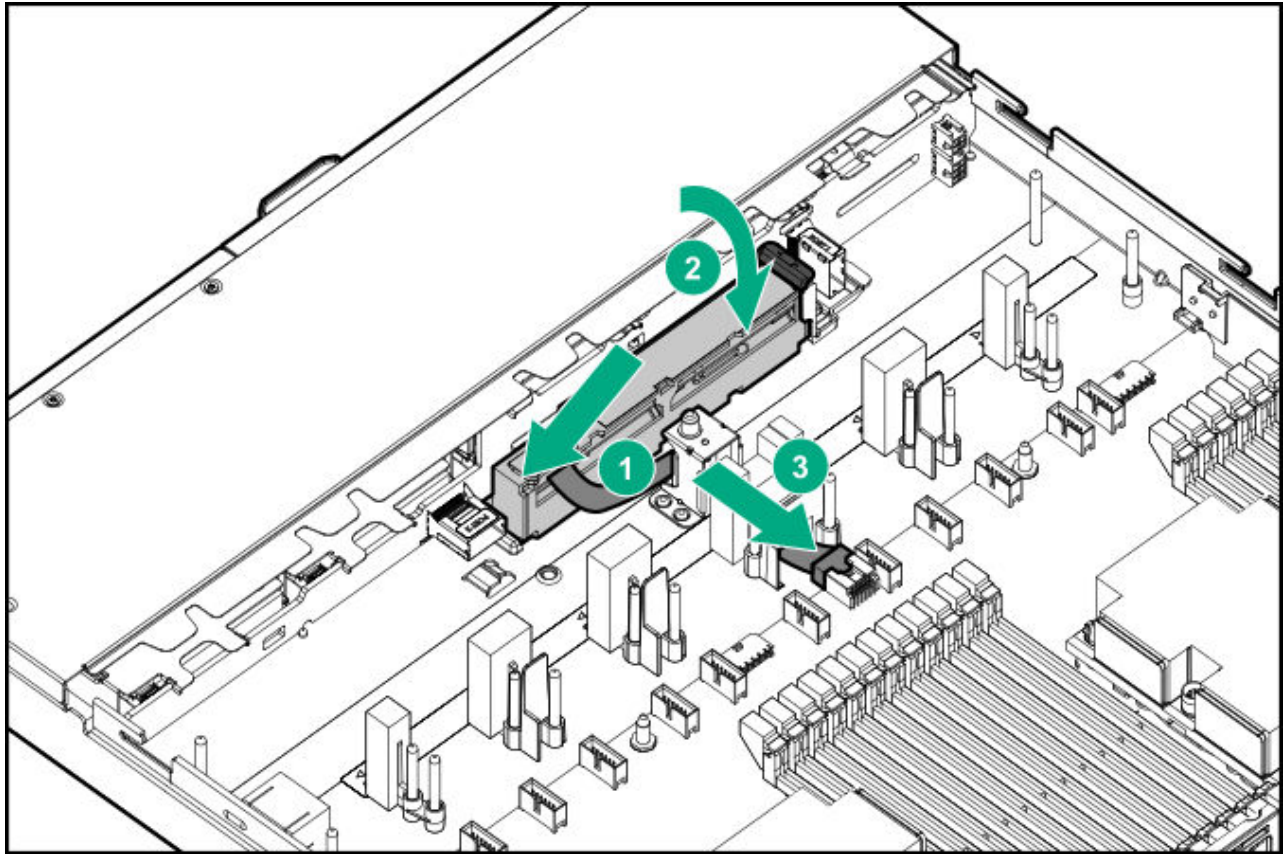

**IMPORTANT:**

To enable SmartCache or CacheCade in a P-class type-p Smart Array controller, you must:

- Connect the controller backup power cable to the controller backup power connector on the system or riser board.
- Connect the energy pack cable to the energy pack connector on the system board.

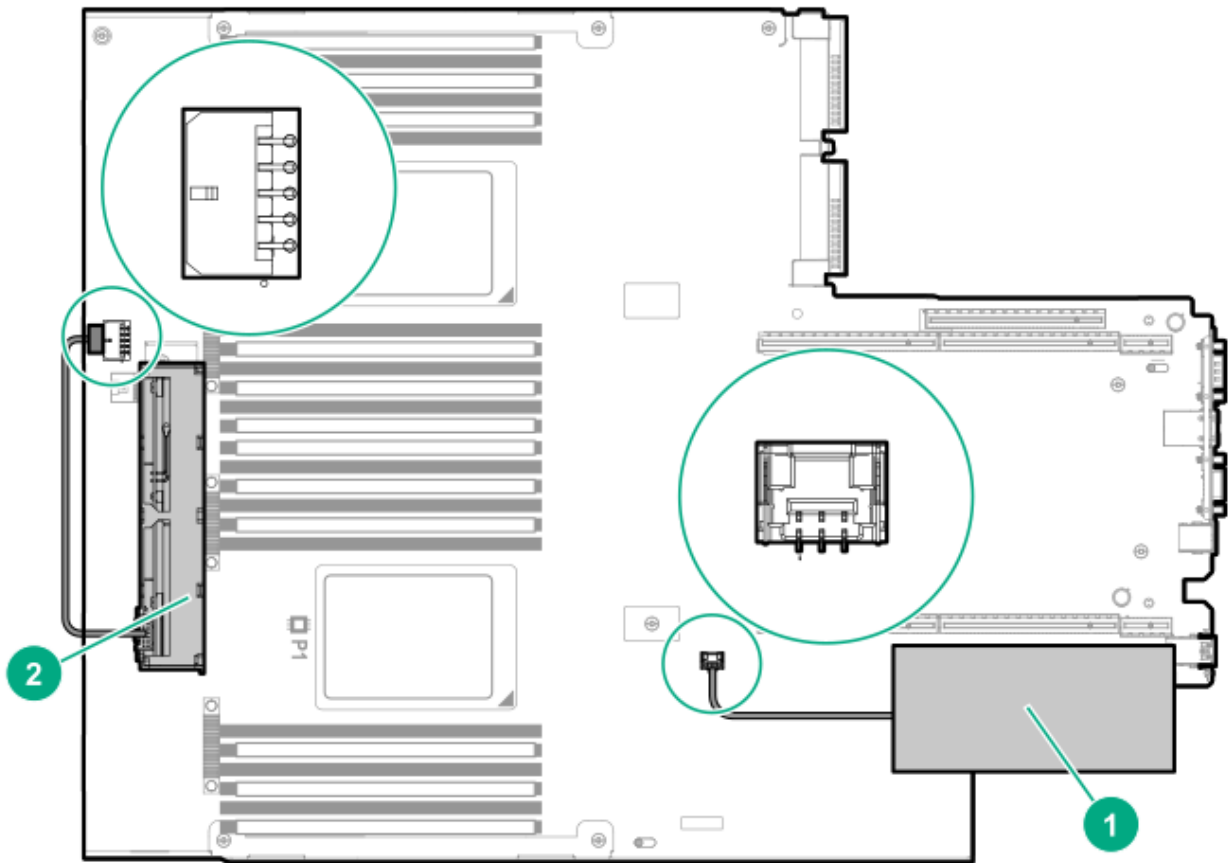

6. Install the access panel ([Install the access panel](#)).
7. Install the server in the rack.
8. Connect each power cord to the server.
9. Connect each power cord to the power source.
10. [Power up the server](#).

## HPE Trusted Platform Module 2.0 Gen10 option

### Subtopics

#### [Overview](#)

#### [HPE Trusted Platform Module 2.0 Guidelines](#)

#### [Installing and enabling the HPE TPM 2.0 Gen10 option](#)

## Overview

Use these instructions to install and enable an HPE TPM 2.0 Gen10 Kit in a supported server. This option is not supported on a Gen9 and earlier server.

This procedure includes three sections:

1. Installing the Trusted Platform Module board.
2. Enabling the Trusted Platform Module.
3. Retaining the recovery key/password.

HPE TPM 2.0 installation is supported with specific operating system support such as Microsoft Windows Server 2012 R2 and later. For more information about operating system support, see the product QuickSpecs on the Hewlett Packard Enterprise website (<https://www.hpe.com/info/qs>). For more information about Microsoft Windows BitLocker Drive Encryption feature, see the Microsoft website (<https://www.microsoft.com>).



**CAUTION:** If the TPM is removed from the original server and powered up on a different server, data stored in the TPM including keys will be erased.



**IMPORTANT:** In UEFI Boot Mode, the HPE TPM 2.0 Gen10 Kit can be configured to operate as TPM 2.0 (default) or TPM 1.2 on a supported server. In Legacy Boot Mode, the configuration can be changed between TPM 1.2 and TPM 2.0, but only TPM 1.2 operation is supported.

## HPE Trusted Platform Module 2.0 Guidelines



**CAUTION:** Always observe the guidelines in this document. Failure to follow these guidelines can cause hardware damage or halt data access.

When installing or replacing a TPM, observe the following guidelines:

- Do not remove an installed TPM. Once installed, the TPM is bound to the system board. If an OS is configured to use the TPM and it is removed, the OS may go into recovery mode, data loss can occur, or both.
- When installing or replacing hardware, Hewlett Packard Enterprise service providers cannot enable the TPM or the encryption technology. For security reasons, only the customer can enable these features.

- When returning a system board for service replacement, do not remove the TPM from the system board. When requested, Hewlett Packard Enterprise Service provides a TPM with the spare system board.
- Any attempt to remove the cover of an installed TPM from the system board can damage the TPM cover, the TPM, and the system board.
- If the TPM is removed from the original server and powered up on a different server, data stored in the TPM including keys will be erased.
- When using BitLocker, always retain the recovery key/password. The recovery key/password is required to complete Recovery Mode after BitLocker detects a possible compromise of system integrity or system configuration.
- Hewlett Packard Enterprise is not liable for blocked data access caused by improper TPM use. For operating instructions, see the TPM documentation or the encryption technology feature documentation provided by the operating system.

## **Installing and enabling the HPE TPM 2.0 Gen10 option**

### **Subtopics**

**[Installing the Trusted Platform Module board](#)**

**[Enabling the Trusted Platform Module](#)**

**[Retaining the BitLocker recovery key/password](#)**

## **Installing the Trusted Platform Module board**

### **Subtopics**

**[Preparing the server for installation](#)**

**[Installing the TPM board and cover](#)**

**[Preparing the server for operation](#)**

# Preparing the server for installation

## Procedure

1. Observe the following warnings:



**WARNING:** The front panel Power On/Standby button does not shut off system power. Portions of the power supply and some internal circuitry remain active until AC power is removed.

To reduce the risk of personal injury, electric shock, or damage to the equipment, remove power from the server:

- For rack and tower servers, remove the power cord.
- For server blades and compute modules, remove the server blade or compute module from the enclosure .



**WARNING:** To reduce the risk of personal injury from hot surfaces, allow the drives and the internal system components to cool before touching them.

2. Update the system ROM.

Locate and download the latest ROM version from the [\*\*Hewlett Packard Enterprise Support Center website\*\*](#). Follow the instructions on the website to update the system ROM.

3. Power down the server ([Power down the server](#)).
4. Remove all power:
  - a. Disconnect each power cord from the power source.
  - b. Disconnect each power cord from the server.
5. Do one of the following:
  - Extend the server from the rack ([Extend the server from the rack](#)).
  - Remove the server from the rack ([Remove the server from the rack](#)).
6. Place the server on a flat, level work surface.
7. Remove the access panel ([Remove the access panel](#)).
8. If needed, remove any expansion boards installed in slot 3.

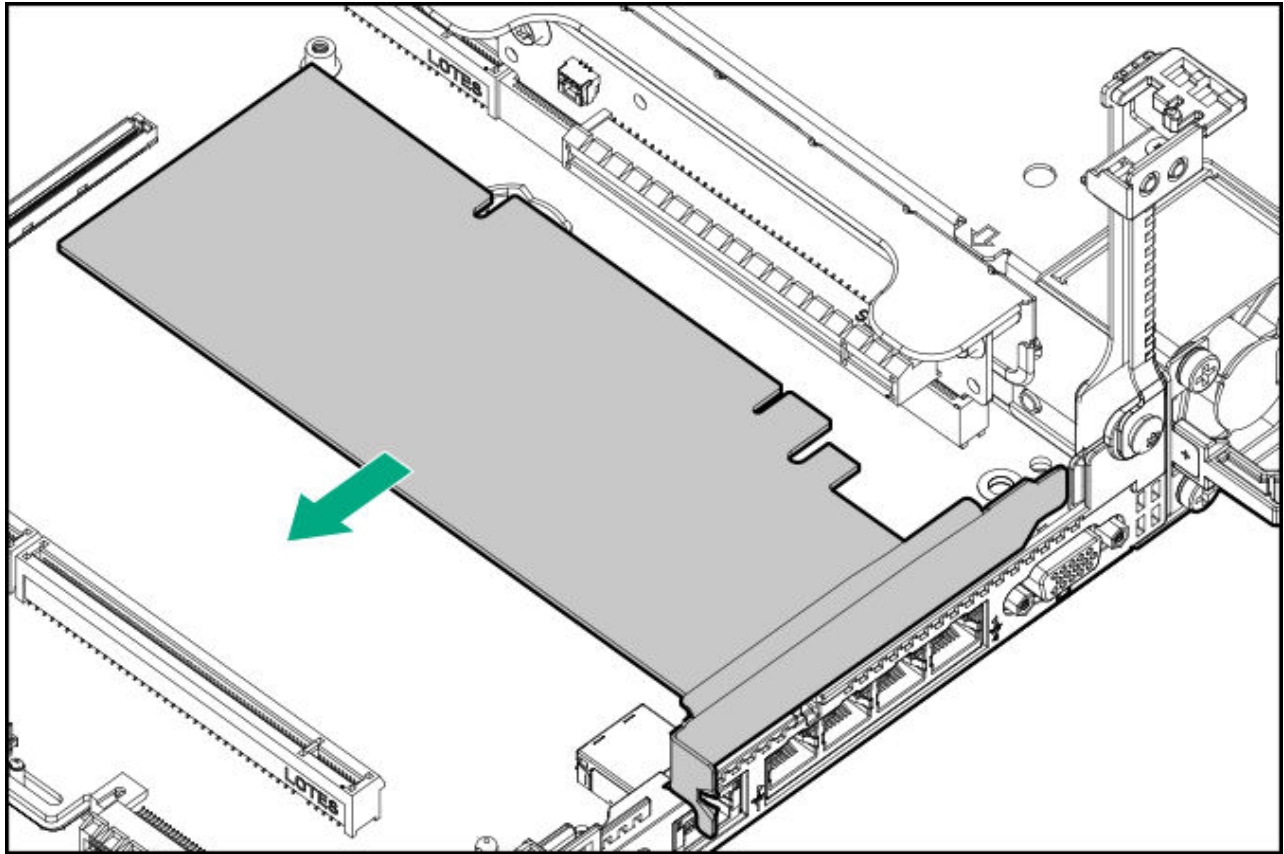

9. Remove the primary PCI riser cage (Remove the primary PCI riser cage).
10. Proceed to Installing the TPM board and cover.

## Installing the TPM board and cover

### Procedure

1. Observe the following alerts:



**CAUTION:** If the TPM is removed from the original server and powered up on a different server, data stored in the TPM including keys will be erased.



**CAUTION:** The TPM is keyed to install only in the orientation shown. Any attempt to install the TPM in a different orientation might result in damage to the TPM or system board.

2. Align the TPM board with the key on the connector, and then install the TPM board. To seat the board, press the TPM board firmly into the connector. To locate the TPM connector on the system board, see the server label on the access panel.

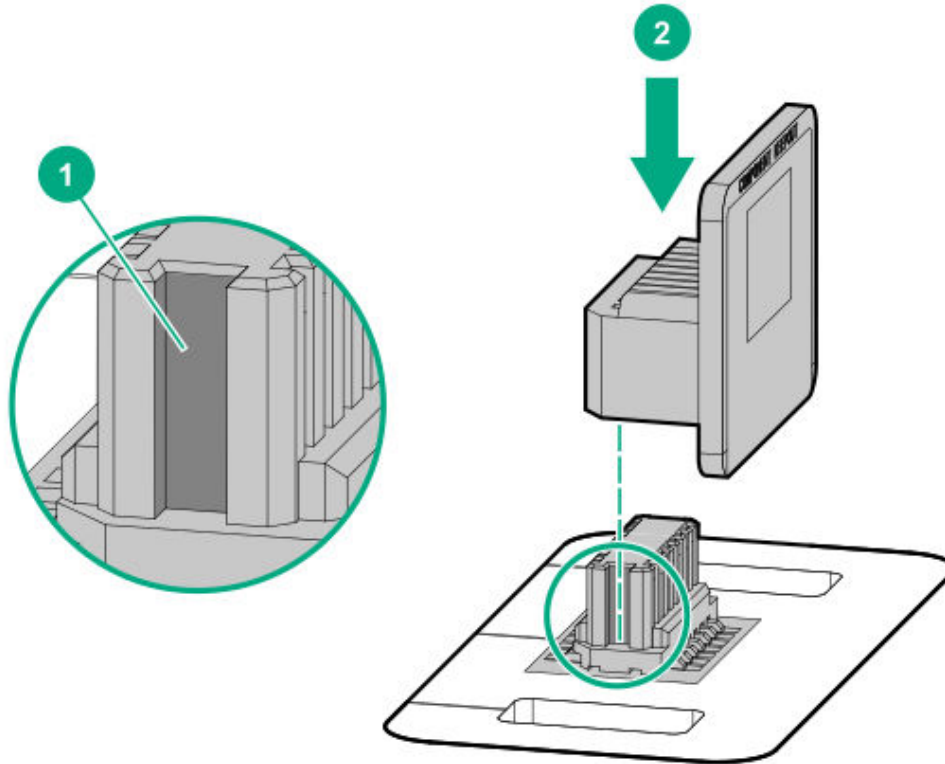

3. Install the TPM cover:
  - a. Line up the tabs on the cover with the openings on either side of the TPM connector.
  - b. To snap the cover into place, firmly press straight down on the middle of the cover.

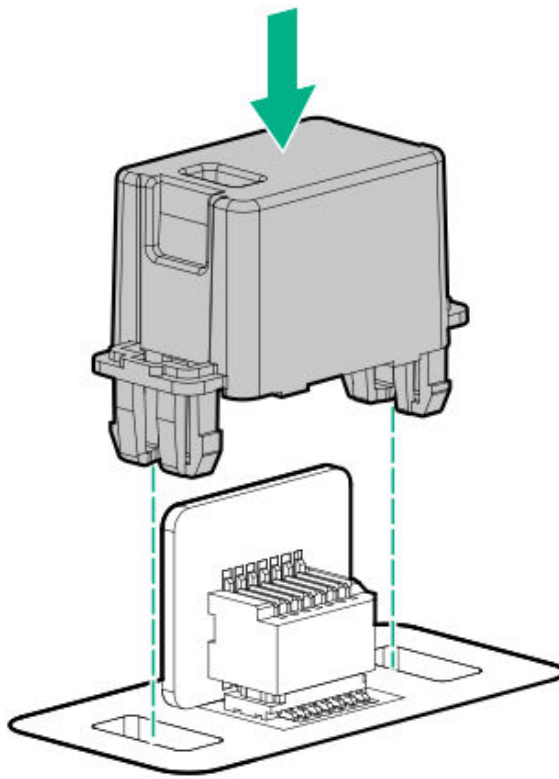

4. Proceed to [Preparing the server for operation](#).

## Preparing the server for operation

### Procedure

1. Install any options or cables previously removed to access the TPM connector.
2. Install the access panel.
3. Do one of the following:
  - a. Install the server in the rack, if necessary.
  - b. Install the server in the enclosure.
4. Power up the server.
  - a. Connect the power cords (rack and tower servers).
  - b. Press the Power On/Standby button.

# Enabling the Trusted Platform Module

When enabling the Trusted Platform module, observe the following guidelines:

- By default, the Trusted Platform Module is enabled as TPM 2.0 when the server is powered on after installing it.
- In UEFI Boot Mode, the Trusted Platform Module can be configured to operate as TPM 2.0 (default) or TPM 1.2.
- In Legacy Boot Mode, the Trusted Platform Module configuration can be changed between TPM 1.2 and TPM 2.0 (default), but only TPM 1.2 operation is supported.

## Subtopics

[Enabling the Trusted Platform Module as TPM 2.0](#)

[Enabling the Trusted Platform Module as TPM 1.2](#)

# Enabling the Trusted Platform Module as TPM 2.0

## About this task

### Procedure

1. From the boot screen, press **F9** to access the UEFI System Utilities.
2. From the **System Utilities** screen, select **System Configuration > BIOS/Platform Configuration (RBSU) > Server Security > Trusted Platform Module options**.
3. Verify the following:
  - "Current TPM Type" is set to **TPM 2.0**.
  - "Current TPM State" is set to **Present and Enabled**.
  - "TPM Visibility" is set to **Visible**.
4. If changes were made in the previous step, press **F10** to save your selection.
5. If **F10** was pressed in the previous step, do one of the following:
  - If in graphical mode, click **Yes**.
  - If in text mode, press the **Y** key.

6. Press **Esc** to exit System Utilities.
7. If changes were made and saved, the server prompts for reboot request. Press **Enter** to confirm reboot.

If the following actions were performed, the server reboots a second time without user input. During this reboot, the TPM setting becomes effective.

- Changing from TPM 1.2 and TPM 2.0
  - Changing TPM bus from FIFO to CRB
  - Enabling or disabling TPM
  - Clearing the TPM
8. Enable TPM functionality in the OS, such as Microsoft Windows BitLocker or measured boot.

For more information, see the [Microsoft website](#).

## Enabling the Trusted Platform Module as TPM 1.2

### About this task

### Procedure

1. From the boot screen, press **F9** to access the UEFI System Utilities.
2. From the **System Utilities** screen, select **System Configuration > BIOS/Platform Configuration (RBSU) > Server Security > Trusted Platform Module options**.
3. Change the **TPM Mode Switch Operation** to **TPM 1.2**.
4. Verify that "TPM Visibility" is set to **Visible**.
5. Press **F10** to save your selection.
6. When prompted to save the change in System Utilities, do one of the following:
  - If in graphical mode, click **Yes**.
  - If in text mode, press the **Y** key.
7. Press **Esc** to exit System Utilities.

The server reboots a second time without user input. During this reboot, the TPM setting becomes effective.

8. Enable TPM functionality in the OS, such as Microsoft Windows BitLocker or measured boot.

For more information, see the [Microsoft website](#).

## Retaining the BitLocker recovery key/password

The recovery key/password is generated during BitLocker setup, and can be saved and printed after BitLocker is enabled. When using BitLocker, always retain the recovery key/password. The recovery key/password is required to enter Recovery Mode after BitLocker detects a possible compromise of system integrity.

To help ensure maximum security, observe the following guidelines when retaining the recovery key/password:

- Always store the recovery key/password in multiple locations.
- Always store copies of the recovery key/password away from the server.
- Do not save the recovery key/password on the encrypted hard drive.

## Cabling

### Subtopics

[Cabling overview](#)

[SFF cables](#)

[LFF cables](#)

## Cabling overview

This section provides guidelines that help you make informed decisions about cabling the server and hardware options to optimize performance.



**CAUTION:** When routing cables, always be sure that the cables are not in a position where they can be pinched or crimped.

## SFF cables

Option kit	Cable part number	Connects from	Connects to
SFF P824i-p Cable Kit	876864-001	8 SFF SAS/SATA Backplane	Port 1i/2i on the P824i-p Smart Array Controller
	876865-002	2 SFF SAS/SATA Backplane	Port 3i on the P824i-p Smart Array Controller
	876866-002	10 SFF SAS/SATA Backplane	Port 1i/2i on the P824i-p Smart Array Controller
SFF Internal Cables Kit	874618-001	2 SFF SAS/SATA Backplane	Embedded SATA
	869662-001	8 SFF SAS/SATA Backplane	Embedded SATA Type -a Smart Array Controller
	876867-001	2 SFF SAS/SATA Backplane	Type -p Smart Array Controller (Slot 1)
	874615-001	8 SFF SAS/SATA Backplane	Type -p Smart Array Controller (Slot 2)
2 SFF Backplane Option Kit	876867-001	2 SFF SAS/SATA Backplane	Embedded SATA Type -p Smart Array Controller
	869669-001	2 SFF SAS/SATA Backplane	P816i-a Smart Array Controller
2 SFF SCM Backplane Option Kit	869668-001	2 SFF SCM Backplane	Embedded SATA
	869669-001	2 SFF SCM Backplane	P816i-a Smart Array Controller
		2 SFF SCM Backplane	Slot 1
1 SFF Rear Backplane Option Kit	869685-001	1 SFF Rear Backplane	Embedded SATA Type -p Smart Array Controller
	876868-001	1 SFF Rear Backplane	P816i-a Smart Array Controller
10 SFF SAS/SATA/NVMe Combo backplane	869675-001	10 SFF backplane, SAS port	P408i-a controller
	869676-001	10 SFF backplane, ports 1, 2, and 3	NVMe riser, ports 1, 2, and 3
	869681-001	10 SFF backplane, port 5	NVMe riser, port 5

Option kit	Cable part number	Connects from	Connects to
	869680-001	10 SFF backplane, port 4	NVMe riser, port 4

## Subtopics

**SFF configuration cable routing**

**Additional SFF cabling**

## SFF configuration cable routing



### NOTE:

The following information describes the standard cable routing for this component. For more information on optional cable routing, see the HPE ProLiant DL360 Gen10 Server cabling matrix on the Hewlett Packard Enterprise website (<https://www.hpe.com/info/CablingMatrixGen10>).

## Subtopics

**SFF backplane to P824i-p controller**

**8 SFF backplane to a P408i-a/P816i-a controller**

**2 SFF backplane to P816i-a controller**

**10 SFF NVMe backplane to NVMe riser**

**2 SFF NVMe backplane to primary riser**

**1 SFF rear backplane to system board SATA**

**10 SFF backplane to P408i-a controller**

## SFF backplane to P824i-p controller

**8 SFF to ports 1i/2i in the primary**

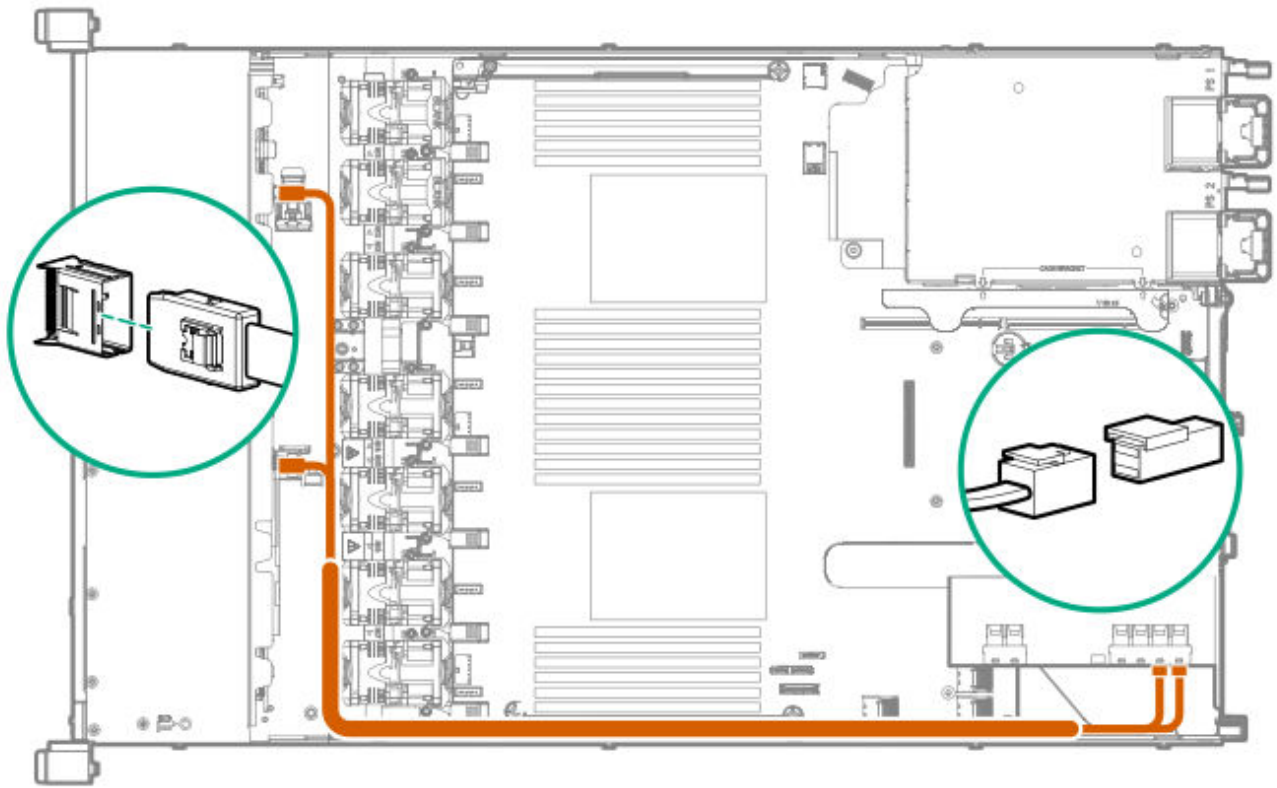

**8 SFF to ports 1i/2i + 2 SFF to port 3i in the primary**



**10 SFF premium backplane to ports 1i/2i in the primary**

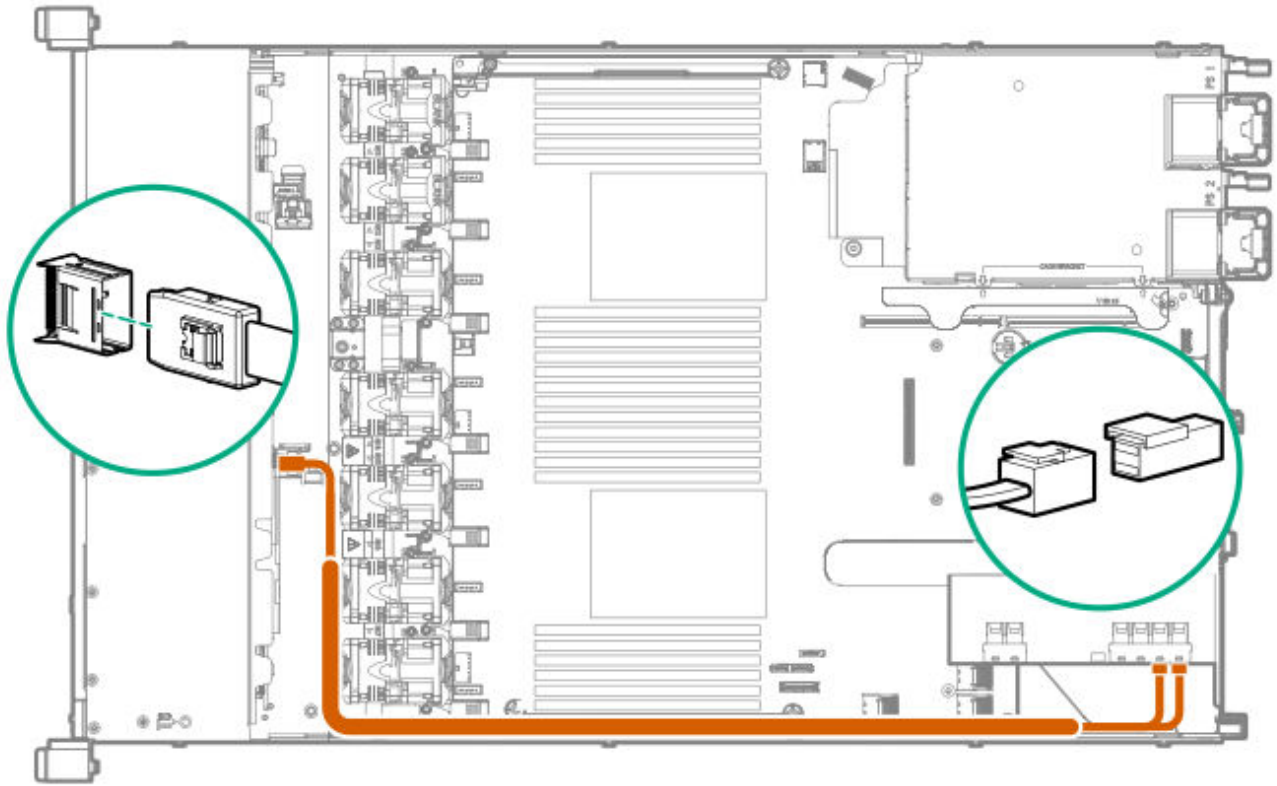

## 8 SFF backplane to a P408i-a/P816i-a controller

A P408i-a controller is shown, but the routing is the same for the P816i-a.



## 2 SFF backplane to P816i-a controller



## 10 SFF NVMe backplane to NVMe riser

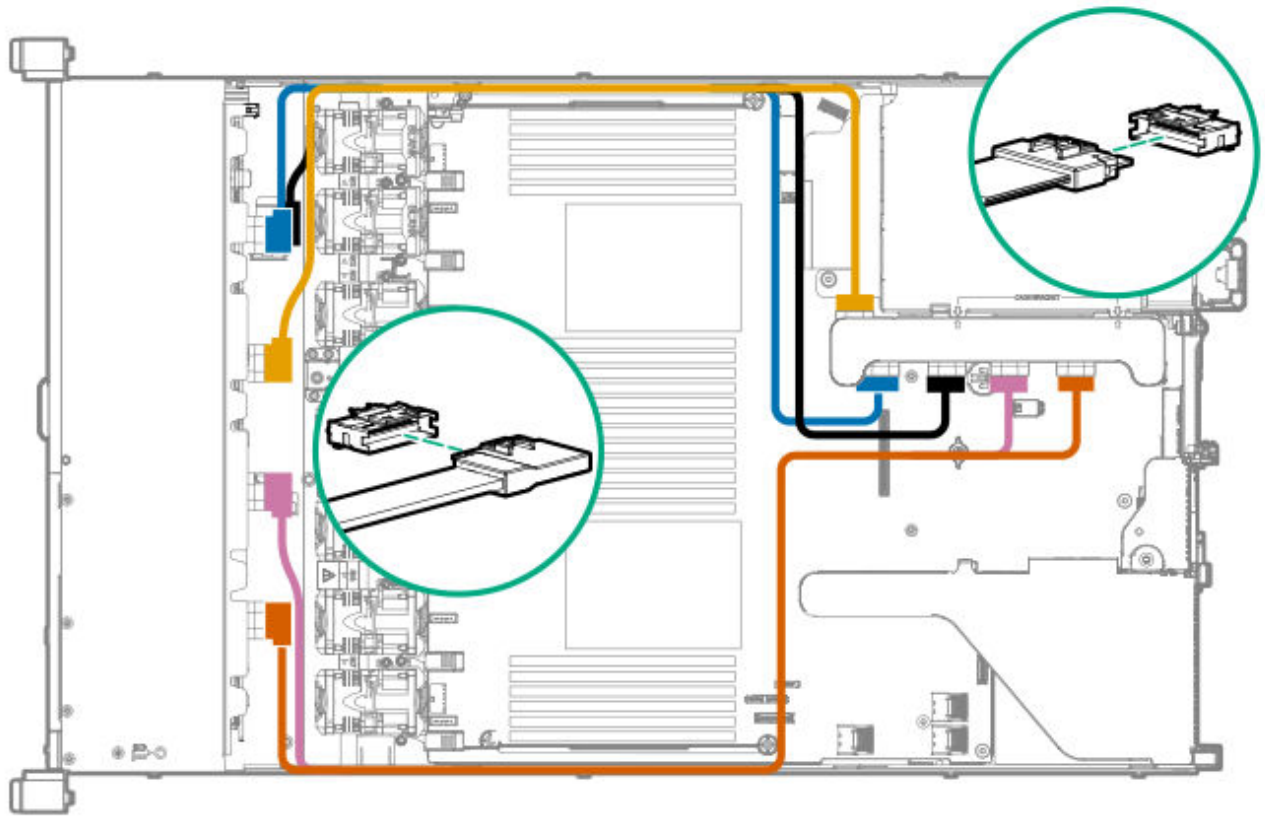

## 2 SFF NVMe backplane to primary riser

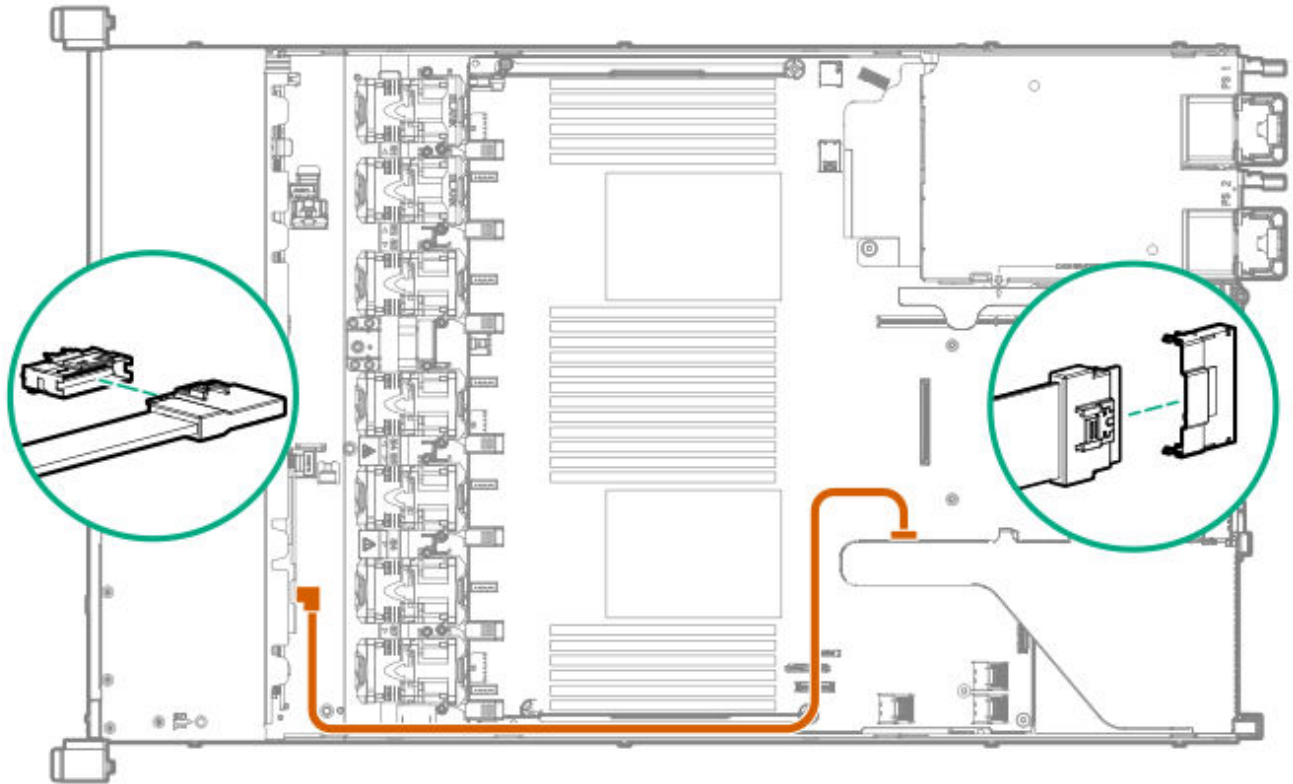

## 1 SFF rear backplane to system board SATA

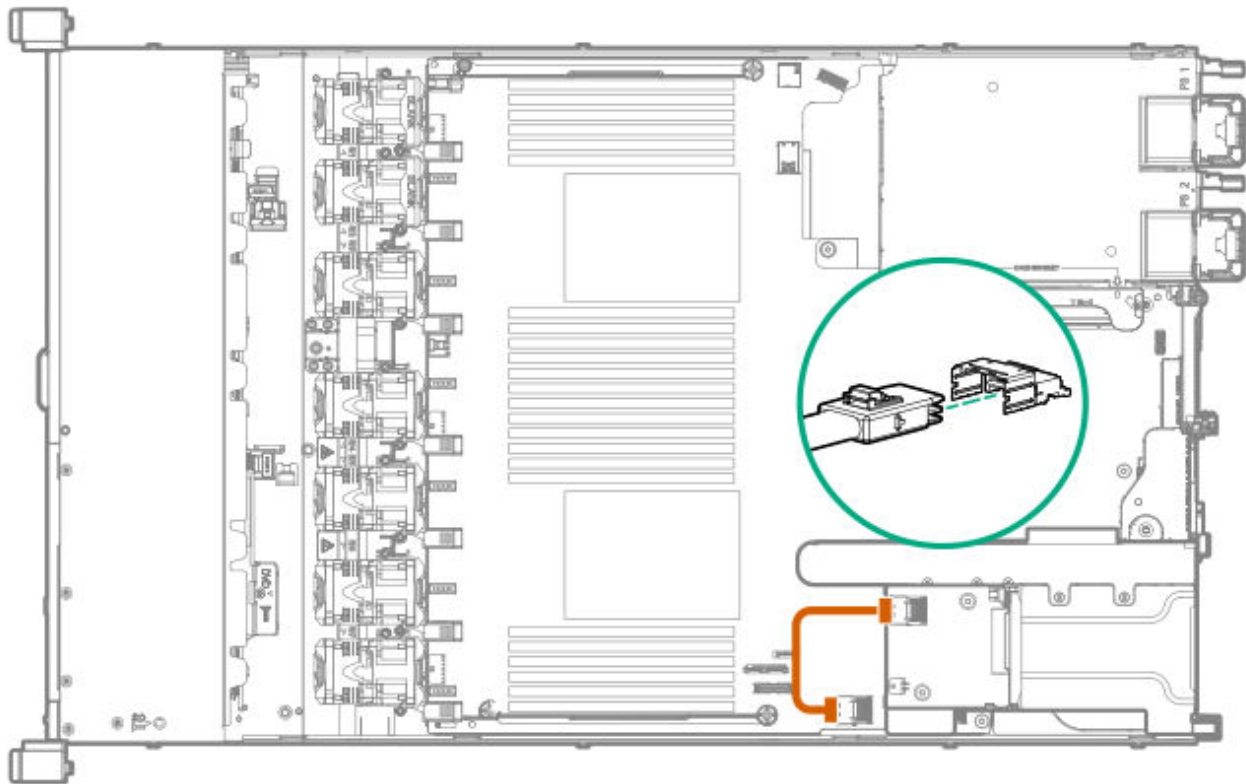

## 10 SFF backplane to P408i-a controller

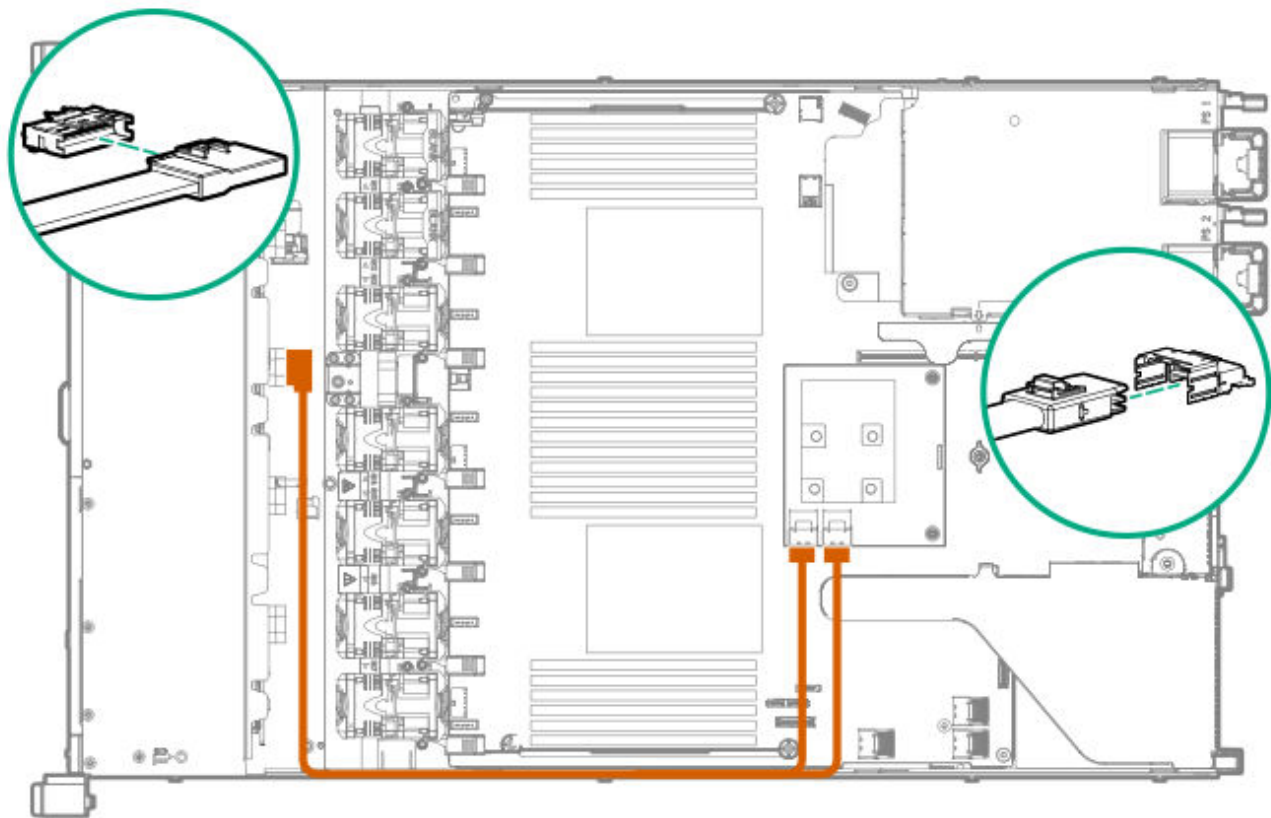

## Additional SFF cabling

For more information on the following cables and cabling configurations, see the HPE DL360 Gen10 Server cabling matrix on the Hewlett Packard Enterprise website (<https://www.hpe.com/info/CablingMatrixGen10>):

- 8 SFF backplane to P408i-p controller
- 8 SFF backplane to system board SATA
- 8 SFF backplane power cable
- 2 SFF backplane to P408i-p controller
- 2 SFF backplane to system board SATA
- 2 SFF to 8 SFF power cable
- 1 SFF rear backplane to P816i-a controller

- SFF system power/USB cable

## LFF cables

Option kit	Cable part number	Connects from	Connects to
HPE Gen10 LFF Internal Cable Kit	869673-001	4 LFF backplane	Type -p Smart Array controller, slot 1 Type -a Smart Array controller Embedded SATA
	874616-001	4 LFF backplane	PCI controller, slot 2
HPE Gen9 LFF Optical Cable Kit	756914-001	LFF optical drive	System board SATA, port 5

### Subtopics

[LFF configuration cable routing](#)

[Additional LFF cabling](#)

## LFF configuration cable routing



### NOTE:

The following information describes the standard cable routing for this component. For more information on optional cable routing, see the HPE ProLiant DL360 Gen10 Server cabling matrix on the Hewlett Packard Enterprise website (<https://www.hpe.com/info/CablingMatrixGen10>).

### Subtopics

[4 LFF backplane to P408i-a controller](#)

## 4 LFF backplane to P408i-a controller

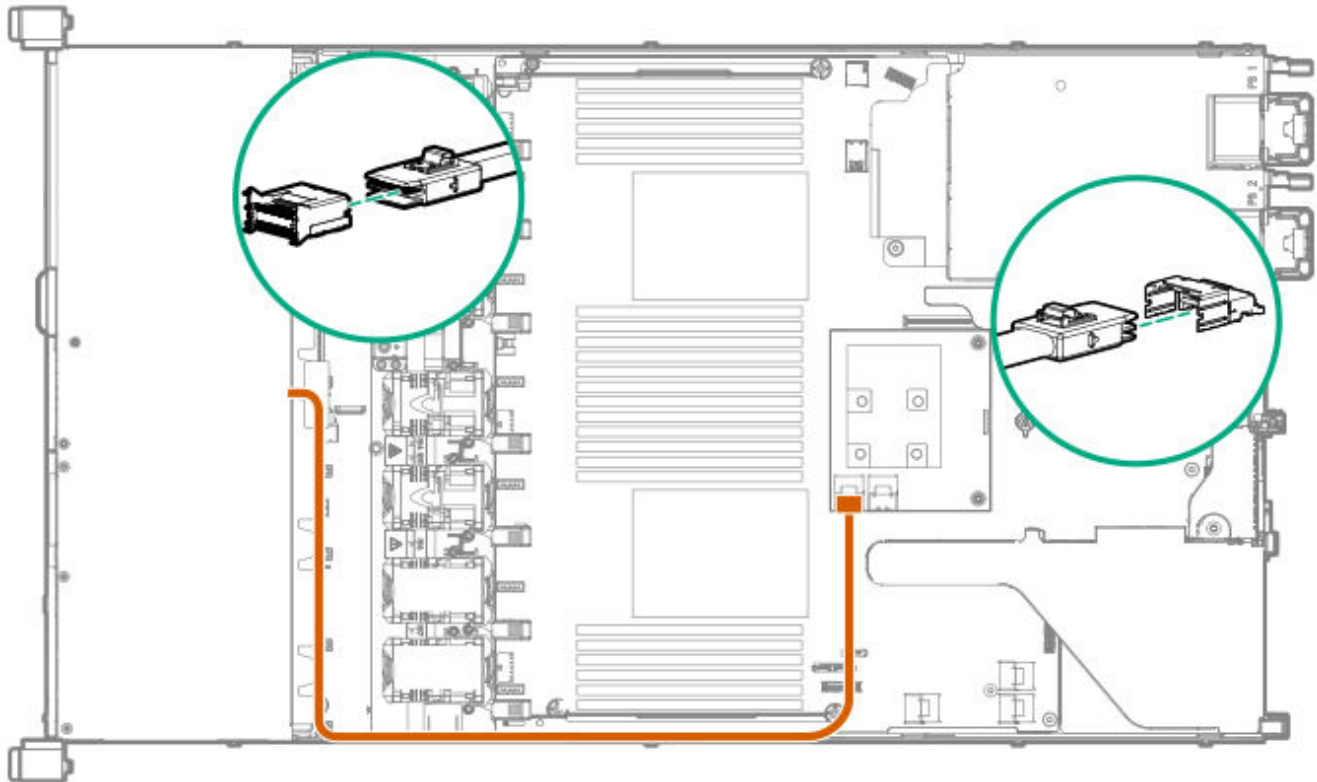

### Additional LFF cabling

For more information on the following cables and cabling configurations, see the HPE DL360 Gen10 Server cabling matrix on the Hewlett Packard Enterprise website (<https://www.hpe.com/info/CablingMatrixGen10>):

- 4 LFF backplane to P408i-p controller
- 4 LFF backplane to system board SATA

### Software and configuration utilities

#### Subtopics

- Server mode**
- HPE iLO 5**
- Integrated Management Log**
- Intelligent Provisioning**
- Management security**
- Scripting Toolkit for Windows and Linux**
- UEFI System Utilities**
- HPE Smart Storage Administrator**
- HPE MR Storage Administrator**
- HPE InfoSight for servers**
- StorCLI**
- USB support**
- Redundant ROM support**
- Keeping the system current**

## Server mode

The software and configuration utilities presented in this section operate in online mode, offline mode, or in both modes.

<b>Software or configuration utility</b>	<b>Server mode</b>
<a href="#"><u>HPE iLO 5</u></a>	Online and Offline
<a href="#"><u>HPE Smart Storage Administrator</u></a>	Online and Offline
<a href="#"><u>iLO RESTful API</u></a>	Online and Offline
<a href="#"><u>Intelligent Provisioning</u></a>	Online and Offline
<a href="#"><u>Scripting Toolkit for Windows and Linux</u></a>	Online
<a href="#"><u>Service Pack for ProLiant</u></a>	Online and Offline
<a href="#"><u>Introduction to Smart Update Manager</u></a>	Online and Offline
<a href="#"><u>UEFI System Utilities</u></a>	Offline
<a href="#"><u>HPE MR Storage Administrator</u></a>	Online
<a href="#"><u>StorCLI</u></a>	Online

# HPE iLO 5

iLO 5 is a remote server management processor embedded on the system boards of supported HPE servers and compute modules. iLO enables the monitoring and controlling of servers from remote locations. iLO management is a powerful tool that provides multiple ways to configure, update, monitor, and repair servers remotely.

For more information about iLO, see the iLO user guide at the following website: <https://www.hpe.com/support/ilo-docs>.

## Subtopics

**iLO Federation**

**iLO RESTful API**

**RESTful Interface Tool**

**Description iLO Amplifier Pack**

## iLO Federation

iLO Federation enables you to manage multiple servers from one system using the iLO web interface.

When configured for iLO Federation, iLO uses multicast discovery and peer-to-peer communication to enable communication between the systems in iLO Federation groups.

When you navigate to one of the iLO Federation pages, a data request is sent from the iLO system running the web interface to its peers, and from those peers to other peers until all data for the selected iLO Federation group is retrieved.

iLO supports the following features:

- Group health status—View server health and model information.
- Group virtual media—Connect URL-based media for access by a group of servers.
- Group power control—Manage the power status of a group of servers.
- Group power capping—Set dynamic power caps for a group of servers.
- Group firmware update—Update the firmware of a group of servers.
- Group license installation—Enter a license key to activate iLO licensed features on a group of servers.
- Group configuration—Add iLO Federation group memberships for multiple iLO systems.

Any user can view information on iLO Federation pages, but a license is required for using the following features: Group virtual media, Group power control, Group power capping, Group configuration, and Group firmware update.

For more information about iLO Federation, see the iLO user guide at the following website: <https://www.hpe.com/support/ilo-docs>.

## iLO RESTful API

iLO includes the iLO RESTful API, which is Redfish API conformant. The iLO RESTful API is a management interface that server management tools can use to perform configuration, inventory, and monitoring tasks by sending basic HTTPS operations (GET, PUT, POST, DELETE, and PATCH) to the iLO web server.

To learn more about the iLO RESTful API, see the Hewlett Packard Enterprise website (<https://www.hpe.com/support/restfulinterface/docs>).

For specific information about automating tasks using the iLO RESTful API, see libraries and sample code at <https://www.hpe.com/info/redfish>.

 For more information, watch the [Redfish & How it works with HPE Server Management](#) video.

## RESTful Interface Tool

The RESTful Interface Tool (iLOREST) is a scripting tool that allows you to automate HPE server management tasks. It provides a set of simplified commands that take advantage of the iLO RESTful API. You can install the tool on your computer for remote use or install it locally on a server with a Windows or Linux Operating System. The RESTful Interface Tool offers an interactive mode, a scriptable mode, and a file-based mode similar to CONREP to help decrease automation times.

For more information, see the following website: <https://www.hpe.com/info/resttool>.

## Description iLO Amplifier Pack

iLO Amplifier Pack is an advanced server inventory, firmware and driver update solution that enables rapid discovery, detailed inventory reporting, firmware, and driver updates by leveraging iLO advanced functionality. iLO Amplifier Pack performs rapid server discovery and inventory for thousands of supported servers for the purpose of updating firmware and drivers at scale.

For more information about iLO Amplifier Pack, see the iLO Amplifier Pack User Guide at the following website: <https://www.hpe.com/support/ilo-ap-ug-en>.

## Integrated Management Log

The IML records hundreds of events and stores them in an easy-to-view form. The IML timestamps each event with one-minute granularity.

You can view recorded events in the IML in several ways, including the following:

- From within HPE SIM
- From within the UEFI System Utilities
- From within the Embedded UEFI shell
- From within the iLO web interface

## Intelligent Provisioning

Intelligent Provisioning is a single-server deployment tool embedded in ProLiant servers and HPE Synergy compute modules. Intelligent Provisioning simplifies server setup, providing a reliable and consistent way to deploy servers.



### NOTE:

- Rapid Setup Software is only available on the ProLiant 300 Series servers or below. When you launch F10 mode from the POST screen, you are prompted to select whether you want to enter the Intelligent Provisioning or HPE Rapid Setup Software mode.
- After you have selected a mode, you must re provision the server to change the mode that launches when you boot to F10.

Intelligent Provisioning prepares the system for installing original, licensed vendor media and Hewlett Packard Enterprise-branded versions of OS software. Intelligent Provisioning also prepares the system to integrate optimized server support software from the Service Pack for ProLiant (SPP). SPP is a comprehensive systems software and firmware solution for ProLiant servers, server blades, their enclosures,

and HPE Synergy compute modules. These components are preloaded with a basic set of firmware and OS components that are installed along with Intelligent Provisioning.



**IMPORTANT:**

HPE ProLiant DX/XL servers do not support operating system installation with Intelligent Provisioning, but they do support the maintenance features. For more information, see "Performing Maintenance" in the Intelligent Provisioning user guide and online help.

After the server is running, you can update the firmware to install additional components. You can also update any components that have been outdated since the server was manufactured.

To access Intelligent Provisioning:

- Press **F10** from the POST screen and enter either Intelligent Provisioning or HPE Rapid Setup Software.
- From the iLO web interface using **Lifecycle Management**. **Lifecycle Management** allows you to access Intelligent Provisioning without rebooting your server.

**Subtopics**

**Intelligent Provisioning operation**

## Intelligent Provisioning operation



**NOTE:**

Intelligent Provisioning 3.40 and later requires iLO firmware version 2.10 or later.

Intelligent Provisioning includes the following components:

- Critical boot drivers
- Active Health System (AHS)
- Erase Utility

- Deployment Settings

**IMPORTANT:**

- Although your server is preloaded with firmware and drivers, Hewlett Packard Enterprise recommends updating the firmware upon initial setup. Also, downloading and updating the latest version of Intelligent Provisioning ensures the latest supported features are available.
- For ProLiant servers, firmware is updated using the Intelligent Provisioning Firmware Update utility.
- Do not update firmware if the version you are currently running is required for compatibility.

**NOTE:**

Intelligent Provisioning does not function within multihomed configurations. A multihomed host is one that is connected to two or more networks or has two or more IP addresses.

Intelligent Provisioning provides installation help for the following operating systems:

- Microsoft Windows Server
- Red Hat Enterprise Linux
- SUSE Linux Enterprise Server
- VMware ESXi/vSphere Custom Image
- ClearOS

Not all versions of an OS are supported. For information about specific versions of a supported operating system, see the OS Support Matrix on the Hewlett Packard Enterprise website (<https://www.hpe.com/info/ossupport>).

## Management security

HPE ProLiant Gen10, HPE ProLiant Gen10 Plus, and HPE Apollo servers are built with some of the industry's most advanced security capabilities, out of the box, with a foundation of secure embedded management applications and firmware. The management security provided by HPE embedded management products enables secure support of modern workloads, protecting your components from unauthorized access and unapproved use. The range of embedded management and optional software and

firmware available with the iLO Advanced license provides security features that help ensure protection, detection, and recovery from advanced cyber attacks. For more information, see the HPE Gen10 and Gen10 Plus Security Reference Guide on the Hewlett Packard Enterprise Information Library at <https://www.hpe.com/support/gen10-security-ref-en>.

## Scripting Toolkit for Windows and Linux

The STK for Windows and Linux is a server deployment product that delivers an unattended automated installation for high-volume server deployments. The STK is designed to support ProLiant servers. The toolkit includes a modular set of utilities and important documentation that describes how to apply these tools to build an automated server deployment process.

The STK provides a flexible way to create standard server configuration scripts. These scripts are used to automate many of the manual steps in the server configuration process. This automated server configuration process cuts time from each deployment, making it possible to scale rapid, high-volume server deployments.

For more information or to download the STK, see the [Hewlett Packard Enterprise website](#).

## UEFI System Utilities

The UEFI System Utilities is embedded in the system ROM. Its features enable you to perform a wide range of configuration activities, including:

- Configuring system devices and installed options.
- Enabling and disabling system features.
- Displaying system information.
- Selecting the primary boot controller or partition.
- Configuring memory options.
- Launching other preboot environments.

HPE servers with UEFI can provide:

- Support for boot partitions larger than 2.2 TB. Such configurations could previously only be used for boot drives when using RAID solutions.
- Secure Boot that enables the system firmware, option card firmware, operating systems, and software collaborate to enhance platform security.

- UEFI Graphical User Interface (GUI)
- An Embedded UEFI Shell that provides a preboot environment for running scripts and tools.
- Boot support for option cards that only support a UEFI option ROM.

## Subtopics

### Selecting the boot mode

#### Secure Boot

#### Launching the Embedded UEFI Shell

## Selecting the boot mode

### About this task

This server provides two **Boot Mode** configurations: UEFI Mode and Legacy BIOS Mode. Certain boot options require that you select a specific boot mode. By default, the boot mode is set to **UEFI Mode**. The system must boot in **UEFI Mode** to use certain options, including:

- Secure Boot, UEFI Optimized Boot, Generic USB Boot, IPv6 PXE Boot, iSCSI Boot, and Boot from URL
- Fibre Channel/FCoE Scan Policy



#### **NOTE:**

The boot mode you use must match the operating system installation. If not, changing the boot mode can impact the ability of the server to boot to the installed operating system.

### Prerequisite

When booting to **UEFI Mode**, leave **UEFI Optimized Boot** enabled.

### Procedure

1. From the **System Utilities** screen, select **System Configuration > BIOS/Platform Configuration (RBSU) > Boot Options > Boot Mode**.
2. Select a setting.
  - **UEFI Mode** (default)—Configures the system to boot to a UEFI compatible operating system.
  - **Legacy BIOS Mode**—Configures the system to boot to a traditional operating system in Legacy BIOS compatibility mode.
3. Save your setting.

4. Reboot the server.

## Secure Boot

Secure Boot is a server security feature that is implemented in the BIOS and does not require special hardware. Secure Boot ensures that each component launched during the boot process is digitally signed and that the signature is validated against a set of trusted certificates embedded in the UEFI BIOS. Secure Boot validates the software identity of the following components in the boot process:

- UEFI drivers loaded from PCIe cards
- UEFI drivers loaded from mass storage devices
- Preboot UEFI Shell applications
- OS UEFI boot loaders

When Secure Boot is enabled:

- Firmware components and operating systems with boot loaders must have an appropriate digital signature to execute during the boot process.
- Operating systems must support Secure Boot and have an EFI boot loader signed with one of the authorized keys to boot. For more information about supported operating systems, see <https://www.hpe.com/servers/ossupport>.

You can customize the certificates embedded in the UEFI BIOS by adding or removing your own certificates, either from a management console directly attached to the server, or by remotely connecting to the server using the iLO Remote Console.

You can configure Secure Boot:

- Using the **System Utilities** options described in the following sections.
- Using the iLO RESTful API to clear and restore certificates. For more information, see the Hewlett Packard Enterprise website (<https://www.hpe.com/info/redfish>).
- Using the `secboot` command in the Embedded UEFI Shell to display Secure Boot databases, keys, and security reports.

# Launching the Embedded UEFI Shell

## Prerequisites

- **Embedded UEFI Shell** is set to **Enabled**.

## About this task

Use the **Embedded UEFI Shell** option to launch the Embedded UEFI Shell. The Embedded UEFI Shell is a preboot command-line environment for scripting and running UEFI applications, including UEFI boot loaders. The Shell also provides CLI-based commands you can use to obtain system information, and to configure and update the system BIOS.

## Procedure

1. From the **System Utilities** screen, select **Embedded Applications > Embedded UEFI Shell**.

The **Embedded UEFI Shell** screen appears.

2. Press any key to acknowledge that you are physically present.

This step ensures that certain features, such as disabling **Secure Boot** or managing the **Secure Boot** certificates using third-party UEFI tools, are not restricted.

3. If an administrator password is set, enter it at the prompt and press **Enter**.

The `Shell>` prompt appears.

4. Enter the commands required to complete your task.
5. Enter the `exit` command to exit the Shell.

## HPE Smart Storage Administrator

HPE SSA is the main tool for configuring arrays on HPE Smart Array SR controllers. It exists in three interface formats: the HPE SSA GUI, the HPE SSA CLI, and HPE SSA Scripting. All formats provide support for configuration tasks. Some of the advanced tasks are available in only one format.

The diagnostic features in HPE SSA are also available in the standalone software HPE Smart Storage Administrator Diagnostics Utility CLI.

During the initial provisioning of the server or compute module, an array is required to be configured before the operating system can be installed. You can configure the array using SSA.

HPE SSA is accessible both offline (either through HPE Intelligent Provisioning or as a standalone bootable ISO image) and online:

- Accessing HPE SSA in the offline environment



**IMPORTANT:** If you are updating an existing server in an offline environment, obtain the latest version of HPE SSA through Service Pack for ProLiant before performing configuration procedures.

Using one of multiple methods, you can run HPE SSA before launching the host operating system. In offline mode, users can configure or maintain detected and supported devices, such as optional Smart Array controllers and integrated Smart Array controllers. Some HPE SSA features are only available in the offline environment, such as setting the boot controller and boot volume.

- Accessing HPE SSA in the online environment

This method requires an administrator to download the HPE SSA executables and install them. You can run HPE SSA online after launching the host operating system.

For more information, see HPE Smart Array SR Gen10 Configuration Guide at the [\*\*Hewlett Packard Enterprise website\*\*](#).

## HPE MR Storage Administrator

HPE MR Storage Administrator is a web-based application that enables you to monitor, configure, maintain, and troubleshoot the HPE Smart Array MR controller. MR Storage Administrator enables you to view, create, and manage storage configurations.



**IMPORTANT:**

The HPE MR Storage Administrator manages **only** the HPE Smart Array MR controllers. It does not manage HPE Smart Array SR controllers.

- **Monitoring and configuring:** MR Storage Administrator enables you to monitor the controllers and configure the drives on the controller. It displays the status of the controller cards, logical drives, and drives on the controller. The device status icons notify you if there are drive failures and other events that require your immediate attention. Email notifications about the status of the server are sent based on your alert settings. The system errors and events are recorded and displayed in an event log file. You can also import or clear foreign configurations.



**IMPORTANT:**

Limited alerting and monitoring is available through iLO when HPE Agentless Management Service is installed. The HPE Smart Array P824i-p MR Gen10 controller supports limited alerts through iLO using the AMS agent.

- **Maintaining:** Using MR Storage Administrator, you can perform system maintenance tasks, such as updating the controller firmware.
- **Troubleshooting:** MR Storage Administrator displays information related to drive failures, device failures, and other issues. It also provides recommendations and displays contextual links, helping you to locate the drives/devices that have issues and troubleshoot them. You can also download a report of the devices and their configurations, properties, and settings and send it to Hewlett Packard Enterprise Support for further troubleshooting.

Obtain MR Storage Administrator installation files through the Service Pack for ProLiant, or SPP, which you can download from the Hewlett Packard Enterprise website (<https://www.hpe.com/servers/spp/download>). Be sure to use the latest SPP version for the server.

For more information about the MR Storage Administrator, see MR Storage Administrator User Guide on the Hewlett Packard Enterprise website (<https://www.hpe.com/info/P824i-pdocs>).

## HPE InfoSight for servers

The HPE InfoSight portal is a secure web interface hosted by HPE that allows you to monitor supported devices through a graphical interface.

HPE InfoSight for servers:

- Combines the machine learning and predictive analytics of HPE InfoSight with the health and performance monitoring of Active Health System (AHS) and HPE iLO to optimize performance and predict and prevent problems
- Provides automatic collection and analysis of the sensor and telemetry data from AHS to derive insights from the behaviors of the install base to provide recommendations to resolve problems and improve performance

For more information on getting started and using HPE InfoSight for servers, go to: <https://www.hpe.com/info/infosight-servers-docs>.

## StorCLI

The Storage Command Line Interface (StorCLI) tool is the command line management software designed for the HPE MegaRAID MR controller. StorCLI is a command line interface that is designed to be easy to use, consistent, and easy to script.

Obtain StorCLI through the Service Pack for ProLiant, or SPP, which you can download from <https://www.hpe.com/servers/spp/download>. Be sure to use the latest SPP version for the server.

For more information about StorCLI, see StorCLI User Guide on the [Hewlett Packard Enterprise website](#).

## USB support

Hewlett Packard Enterprise Gen10 and Gen10 Plus servers support all USB operating speeds depending on the device that is connected to the server.

### Subtopics

#### External USB functionality

## External USB functionality

Hewlett Packard Enterprise provides external USB support to enable local connection of USB devices for server administration, configuration, and diagnostic procedures.

For additional security, external USB functionality can be disabled through USB options in UEFI System Utilities.

## Redundant ROM support

The server enables you to upgrade or configure the ROM safely with redundant ROM support. The server has a single ROM that acts as two separate ROM images. In the standard implementation, one side of the ROM contains the current ROM program version, while the other side of the ROM contains a backup version.



**NOTE:** The server ships with the same version programmed on each side of the ROM.

### Subtopics

#### Safety and security benefits

## Safety and security benefits

When you flash the system ROM, the flashing mechanism writes over the backup ROM and saves the current ROM as a backup, enabling you to switch easily to the alternate ROM version if the new ROM becomes

corrupted for any reason. This feature protects the existing ROM version, even if you experience a power failure while flashing the ROM.

## Keeping the system current

### Subtopics

[Updating firmware or system ROM](#)

[Drivers](#)

[Software and firmware](#)

[Operating system version support](#)

[HPE Pointnext Portfolio](#)

[Proactive notifications](#)

## Updating firmware or system ROM

### About this task

To update firmware or system ROM, use one of the following methods:

- The **Firmware Update** option in the System Utilities.
- The `fwupdate` command in the **Embedded UEFI Shell**.
- Service Pack for ProLiant (SPP)
- HPE online flash components
- Moonshot Component Pack

### Subtopics

[Service Pack for ProLiant](#)

[Updating firmware from the System Utilities](#)

[Updating the firmware from the UEFI Embedded Shell](#)

[Online Flash components](#)

# Service Pack for ProLiant

SPP is a systems software and firmware solution delivered as a single ISO file download. This solution uses SUM as the deployment tool and is tested and supports HPE ProLiant, HPE BladeSystem, HPE Synergy, and HPE Apollo servers and infrastructure.

SPP, along with SUM and iSUT, provides Smart Update system maintenance tools that systematically update HPE ProLiant, HPE BladeSystem, HPE Synergy, and HPE Apollo servers and infrastructure.

SPP can be used in an online mode on a server running Windows, Linux, or VMware vSphere ESXi, or in an offline mode where the server is booted to an operating system included in the ISO file.

The preferred method for downloading an SPP is using the SPP Custom Download at <https://www.hpe.com/servers/spp/custom>.

## Subtopics

[Introduction to Smart Update Manager](#)

[Integrated Smart Update Tools](#)

## Introduction to Smart Update Manager

SUM is an innovative tool for maintaining and updating the firmware, drivers, and system software of HPE ProLiant, HPE BladeSystem, HPE Synergy, HPE Superdome Flex servers, HPE Edgeline and HPE Apollo servers, infrastructure, and associated options.

SUM identifies associated nodes that you can update at the same time to avoid interdependency issues.

The Key features of SUM include:

- Discovery engine that finds installed versions of hardware, firmware, and software on nodes.
- SUM deploys updates in the correct order and ensures that all dependencies are met before deploying an update.
- Interdependency checking.
- Automatic and step-by-step Localhost Guided Update process.
- Web browser-based user interface.
- Ability to create custom baselines and ISOs.
- Support for iLO Repository (Gen10/iLO5 and later nodes only).
- Simultaneous firmware and software deployment for multiple remote nodes.
- Local offline firmware deployments with SPP deliverables.

- Extensive logging in all modes.

**NOTE:**

Support for HPE Integrity servers has been discontinued from SUM 8.x.

## Integrated Smart Update Tools

Integrated Smart Update Tools (SUT) is the smart update solution for performing online firmware and driver updates. SUT is used with iLO 4, iLO 5, and with update solutions (management appliances such as iLO Amplifier Pack or HPE OneView and Smart Update Manager (SUM) to stage, install, and activate firmware and driver updates.

The solution must be installed on the operating system, where it updates results through Rich Infrastructure Services (RIS) communication.

- **SUT:** Polls iLO to check for requests from SUM, iLO Amplifier Pack, or HPE OneView for updates through local iLO using the iLO channel interface driver installed on the OS and orchestrates staging, deploying, and activating updates. You can adjust the polling interval by issuing the appropriate command-line option provided by SUT. Performs inventory on target servers, stages deployment, deploys updates, and then reboots the servers.
- **iLO 5 with integrated Smart Update** (Gen10 or later servers only): Performs iLO Repository-based updates by downloading the components from iLO Repository when iLO Installation Queue has the components which can be updated by SUT.
- **iLO Amplifier Pack and HPE OneView:** Displays available updates for servers. Communicates with SUT (or SUT 1.x) to initiate updates using the iLO Redfish interface. SUT reports the status of updates to iLO Amplifier Pack through iLO Restful Interface.
- **SUM:** A tool for firmware and driver maintenance for HPE ProLiant servers and associated options.

**NOTE:**

SUM and iLO Amplifier Pack should not manage the same nodes.

## Updating firmware from the System Utilities

### About this task

Use the **Firmware Updates** option to update firmware components in the system, including the system BIOS, NICs, and storage cards.

## Procedure

1. Access the System ROM Flash Binary component for your server from the Hewlett Packard Enterprise Support Center.
2. Copy the binary file to a USB media or iLO virtual media.
3. Attach the media to the server.
4. Launch the **System Utilities**, and select **Embedded Applications > Firmware Update**.
5. Select a device.

The **Firmware Updates** screen lists details about your selected device, including the current firmware version in use.

6. Select **Select Firmware File**.
7. Select the flash file in the **File Explorer** list.

The firmware file is loaded and the **Firmware Updates** screen lists details of the file in the **Selected firmware file** field.

8. Select **Image Description**, and then select a firmware image.

A device can have multiple firmware images.

9. Select **Start firmware update**.

## Updating the firmware from the UEFI Embedded Shell

### Procedure

1. Access the System ROM Flash Binary component for your server from the Hewlett Packard Enterprise Support Center (<https://www.hpe.com/support/hpesc>).
2. Copy the binary file to a USB media or iLO virtual media.
3. Attach the media to the server.
4. Boot to the UEFI Embedded Shell.
5. To obtain the assigned file system volume for the USB key, enter `map -r`.
6. Change to the file system that contains the System ROM Flash Binary component for your server. Enter one of the `fsx` file systems available, such as `fs0:` or `fs1:`, and press **Enter**.

7. Use the `cd` command to change from the current directory to the directory that contains the binary file.
8. Flash the system ROM by entering `fwupdate -d BIOS -f filename`.
9. Reboot the server. A reboot is required after the firmware update in order for the updates to take effect and for hardware stability to be maintained.

## Online Flash components

This component provides updated system firmware that can be installed directly on supported operating systems. Additionally, when used in conjunction with SUM, this Smart Component allows the user to update firmware on remote servers from a central location. This remote deployment capability eliminates the need for the user to be physically present at the server to perform a firmware update.

## Drivers



**IMPORTANT:** Always perform a backup before installing or updating device drivers.

Update drivers using any of the following **Smart Update Solutions**:

- Download the latest Service Pack for ProLiant (includes Smart Update Manager)
- Create a custom SPP download
- Download Smart Update Manager for Linux
- Download specific drivers

To locate the drivers for a server, go to the **[Hewlett Packard Enterprise Support Center website](#)**, and then search for the product name/number.

## Software and firmware

Update software and firmware before using the server for the first time, unless any installed software or components require an older version.

For system software and firmware updates, use one of the following sources:

- Download the SPP from the Hewlett Packard Enterprise website (<https://www.hpe.com/servers/spp/download>).
- Download individual drivers, firmware, or other system software components from the server product page in the Hewlett Packard Enterprise Support Center website (<https://www.hpe.com/support/hpesc>).

## Operating system version support

For information about specific versions of a supported operating system, refer to the [operating system support matrix](#).

## HPE Pointnext Portfolio

HPE Pointnext delivers confidence, reduces risk, and helps customers realize agility and stability. Hewlett Packard Enterprise helps customers succeed through Hybrid IT by simplifying and enriching the on-premise experience, informed by public cloud qualities and attributes.

Operational Support Services enable you to choose the right service level, length of coverage, and response time to fit your business needs. For more information, see the Hewlett Packard Enterprise website:

<https://www.hpe.com/us/en/services/operational.html>

Utilize the Advisory and Transformation Services in the following areas:

- Private or hybrid cloud computing
- Big data and mobility requirements
- Improving data center infrastructure
- Better use of server, storage, and networking technology

For more information, see the Hewlett Packard Enterprise website:

<https://www.hpe.com/services/consulting>

## Proactive notifications

30 to 60 days in advance, Hewlett Packard Enterprise sends notifications to subscribed customers on upcoming:

- Hardware, firmware, and software changes
- Bulletins
- Patches
- Security alerts

You can subscribe to proactive notifications on the [\*\*Hewlett Packard Enterprise website\*\*](#).

## Troubleshooting

### Subtopics

#### [\*\*Troubleshooting resources\*\*](#)

## Troubleshooting resources

Troubleshooting resources are available for HPE Gen10 and Gen10 Plus server products in the following documents:

- Troubleshooting Guide for HPE ProLiant Gen10 and Gen10 Plus servers provides procedures for resolving common problems and comprehensive courses of action for fault isolation and identification, issue resolution, and software maintenance.
- Error Message Guide for HPE ProLiant Gen10 servers and HPE Synergy provides a list of error messages and information to assist with interpreting and resolving error messages.
- Integrated Management Log Messages and Troubleshooting Guide for HPE ProLiant Gen10 and Gen10 Plus servers and HPE Synergy provides IML messages and associated troubleshooting information to resolve critical and cautionary IML events.

To access troubleshooting resources for your product, see the [\*\*Hewlett Packard Enterprise website\*\*](#).

# Removing and replacing the system battery

## About this task

The system battery provides power to the real-time clock. If the server no longer automatically displays the correct date and time, you might need to replace the system battery.



**WARNING:** The computer contains an internal lithium manganese dioxide, a vanadium pentoxide, or an alkaline battery pack. A risk of fire and burns exists if the battery pack is not properly handled. To reduce the risk of personal injury:

- Do not attempt to recharge the battery.
- Do not expose the battery to temperatures higher than 60°C (140°F).
- Do not expose the battery to extremely low air pressure as it might lead to explosion or leakage of flammable liquid or gas.
- Do not disassemble, crush, puncture, short external contacts, or dispose of in fire or water.
- Replace only with the spare designated for this product.

## Procedure

1. Power down the server ([Power down the server](#)).
2. Remove all power:
  - Disconnect each power cord from the power source.
  - Disconnect each power cord from the server.
3. Do one of the following:
  - a. Extend the server from the rack ([Extend the server from the rack](#)).
  - b. Remove the server from the rack ([Remove the server from the rack](#)).
4. Remove the access panel ([Remove the access panel](#)).
5. Locate the battery ([System board components](#)).
6. Remove the battery.

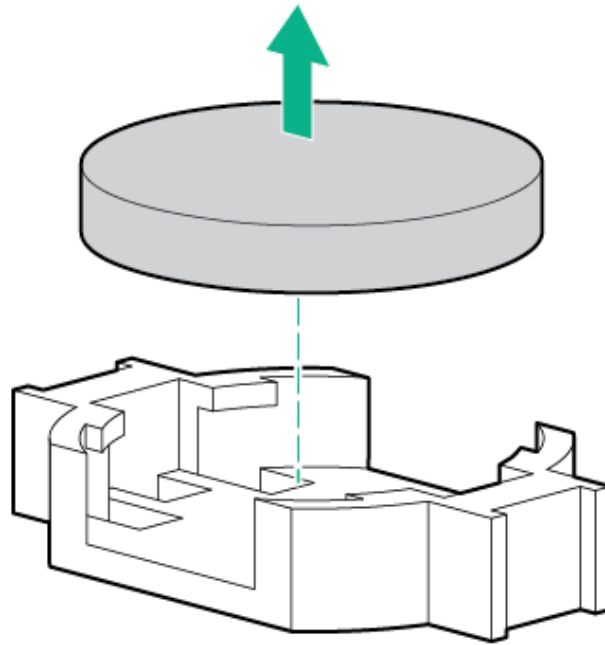

7. To replace the component, reverse the removal procedure.
8. Properly dispose of the old battery.

For more information about battery replacement or proper disposal, contact an authorized reseller or an authorized service provider.

## Specifications

### Subtopics

**[Environmental specifications](#)**

**[Server specifications](#)**

**[Power supply specifications](#)**

**[Hot-plug power supply calculations](#)**

## Environmental specifications

Specification	Value
<b>Temperature range</b> <sup>1</sup> <sub>—</sub>	—
Operating	10°C to 35°C (50°F to 95°F)
Non-operating	-30°C to 60°C (-22°F to 140°F)
<b>Relative humidity (non-condensing)</b>	—
Operating	Minimum to be the higher (more moisture) of -12°C (10.4°F) dew point or 8% relative humidity  Maximum to be 24°C (75.2°F) dew point or 90% relative humidity
Non-operating	5% to 95%  38.7°C (101.7°F), maximum wet bulb temperature

<sup>1</sup><sub>—</sub> All temperature ratings shown are for sea level. An altitude derating of 1.0°C per 304.8 m (1.8°F per 1000 ft) to 3048 m (10,000 ft) is applicable. No direct sunlight allowed. Maximum rate of change is 20°C per hour (36°F per hour). The upper limit and rate of change might be limited by the type and number of options installed.

For certain approved hardware configurations, the supported system inlet temperature range is extended:

- 5°C to 10°C (41°F to 50°F) and 35°C to 40°C (95°F to 104°F) at sea level with an altitude derating of 1.0°C per every 175 m (1.8°F per every 574 ft) above 900 m (2953 ft) to a maximum of 3048 m (10,000 ft).
- 40°C to 45°C (104°F to 113°F) at sea level with an altitude derating of 1.0°C per every 125 m (1.8°F per every 410 ft) above 900 m (2953 ft) to a maximum of 3048 m (10,000 ft).

The approved hardware configurations for this system are listed on the [Hewlett Packard Enterprise website](#).

## Server specifications

Specification	Value
Height	4.29 cm (1.69 in)

Specification	Value
Depth (chassis with SFF drive cage)	70.7 cm (27.83 in)
Depth (chassis with LFF drive cage)	74.98 cm (29.50 in)
Width	43.46 cm (17.11 in)
<b>Weights</b>	
SFF minimum (one drive, one processor, one power supply, two heatsinks, one Smart Array controller, five fans)	13.04 kg (28.74 lb)
SFF maximum (10 drives, two processors, two power supplies, two heatsinks, one Smart Array controller, seven fans)	16.27 kg (35.86 lb)
LFF minimum (one drive, one processor, one power supply, two heatsinks, one Smart Array controller, five fans)	13.77 kg (30.36 lb)
LFF maximum (Four drives, two processors, two power supplies, two heatsinks, one Smart Array controller, seven fans)	16.78 kg (37 lb)

## Power supply specifications

Depending on the installed options and the regional location where the server was purchased, the server can be configured with one of the following power supplies:

- [HPE 500 W Flex Slot Platinum Hot-plug Low Halogen Power Supply](#)
- [HPE 800 W Flex Slot Platinum Hot-plug Low Halogen Power Supply](#)
- [HPE 800 W Flex Slot Titanium Hot-plug Low Halogen Power Supply](#)
- [HPE 800 W Flex Slot Universal Hot-plug Low Halogen Power Supply](#)
- [HPE 800 W Flex Slot -48 VDC Hot-plug Low Halogen Power Supply](#)
- [HPE 1600 W Flex Slot Platinum Hot-plug Low Halogen Power Supply](#)

For detailed power supply specifications, see the QuickSpecs on the Hewlett Packard Enterprise website (<https://www.hpe.com/info/proliant/powersupply>).

### Subtopics

#### [HPE 500 W Flex Slot Platinum Hot-plug Low Halogen Power Supply](#)

- [HPE 800 W Flex Slot Platinum Hot-plug Low Halogen Power Supply](#)
- [HPE 800 W Flex Slot Titanium Hot-plug Low Halogen Power Supply](#)
- [HPE 800 W Flex Slot Universal Hot-plug Low Halogen Power Supply](#)
- [HPE 800 W Flex Slot -48 VDC Hot-plug Low Halogen Power Supply](#)
- [HPE 1600 W Flex Slot Platinum Hot-plug Low Halogen Power Supply](#)

## HPE 500 W Flex Slot Platinum Hot-plug Low Halogen Power Supply

Specification	Value
<b>Input requirements</b>	—
Rated input voltage	100 VAC to 240 VAC 240 VDC for China
Rated input frequency	50 Hz to 60 Hz Not applicable to 240 VDC
Rated input current	5.8 A at 100 VAC 2.8 A at 200 VAC 2.4 A at 240 VDC for China
Maximum rated input power	580 W at 100 VAC 560 W at 200 VAC 558 W at 240 VDC for China
BTUs per hour	1999 at 100 VAC 1912 at 200 VAC 1904 at 240 VDC for China
<b>Power supply output</b>	—
Rated steady-state power	500 W at 100 VAC to 127 VAC input 500 W at 100 VAC to 240 VAC input 500 W at 240 VDC input for China
Maximum peak power	500 W at 100 VAC to 127 VAC input 500 W at 100 VAC to 240 VAC input 500 W at 240 VDC input for China

# HPE 800 W Flex Slot Platinum Hot-plug Low Halogen Power Supply

Specification	Value
<b>Input requirements</b>	—
Rated input voltage	100 VAC to 127 VAC 200 VAC to 240 VAC 240 VDC for China only
Rated input frequency	50 Hz to 60 Hz Not applicable to 240 VDC
Rated input current	9.4 A at 100 VAC 4.5 A at 200 VAC 3.8 A at 240 VDC for China only
Maximum rated input power	940 W at 100 VAC 900 W at 200 VAC 897 W at 240 VDC for China only
BTUs per hour	3067 at 100 VAC 2958 at 200 VAC 2949 at 240 VAC for China only
<b>Power supply output</b>	—
Rated steady-state power	800 W at 100 VAC to 127 VAC input 800 W at 100 VAC to 240 VAC input 800 W at 240 VDC input for China only
Maximum peak power	800 W at 100 VAC to 127 VAC input 800 W at 100 VAC to 240 VAC input 800 W at 240 VDC input for China only

# HPE 800 W Flex Slot Titanium Hot-plug Low Halogen Power Supply

Specification	Value
<b>Input requirements</b>	—
Rated input voltage	200 VAC to 240 VAC 240 VDC for China
Rated input frequency	50 Hz to 60 Hz Not applicable to 240 VDC
Rated input current	4.35 A at 200 VAC 3.62 A at 240 VAC 3.62 A at 240 VDC for China
Maximum rated input power	867 W at 200 VAC 848 W at 240 VAC 848 W at 240 VDC for China
BTUs per hour	2905 at 200 VAC 2893 at 240 VAC 2893 at 240 VDC for China
<b>Power supply output</b>	—
Rated steady-state power	800 W at 200 VAC to 240 VAC input 800 W at 240 VDC input for China
Maximum peak power	800 W at 200 VAC to 240 VAC input 800 W at 240 VDC input for China

# HPE 800 W Flex Slot Universal Hot-plug Low Halogen Power Supply

Specification	Value
<b>Input requirements</b>	—

<b>Specification</b>	<b>Value</b>
Rated input voltage	200 VAC to 277 VAC 380 VDC
Rated input frequency	50 Hz to 60 Hz
Rated input current	4.4 A at 200 VAC 3.8 A at 230 VAC 2.3 A at 380 VDC
Maximum rated input power	869 W at 200 VAC 865 W at 230 VAC 861 W at 277 VAC 863 W at 380 VDC
BTUs per hour	2964 at 200 VAC 2951 at 230 VAC 2936 at 277 VAC 2943 at 380 VDC
<b>Power supply output</b>	—
Rated steady-state power	800 W at 200 VAC to 277 VAC input
Maximum peak power	800 W at 200 VAC to 277 VAC input

## HPE 800 W Flex Slot -48 VDC Hot-plug Low Halogen Power Supply

<b>Specification</b>	<b>Value</b>
<b>Input requirements</b>	—
Rated input voltage	-40 VDC to -72 VDC -48 VDC nominal input
Rated input current	22.1 A at -40 VDC input 18.2 A at -48 VDC input, nominal input 12.0 A at -72 VDC input

<b>Specification</b>	<b>Value</b>
Rated input power	874 W at -40 VDC input
	865 W at -48 VDC input, nominal input
	854 W at -72 VDC input
Rated input power (BTUs per hour)	2983 at -40 VDC input
	2951 at -48 VDC input, nominal input
	2912 at -72 VDC input
<b>Power supply output</b>	—
Rated steady-state power	800 W at -40 VDC to -72 VDC
Maximum peak power	800 W at -40 VDC to -72 VDC

**Specification****Value**

Maximum peak power

800 W at -40 VDC to -72 VDC input

**WARNING:** To reduce the risk of electric shock or energy hazards:

- This equipment must be installed by trained service personnel.
- Connect the equipment to a reliably grounded secondary circuit source. A secondary circuit has no direct connection to a primary circuit and derives its power from a transformer, converter, or equivalent isolation device.
- The branch circuit overcurrent protection must be rated 27 A.

**CAUTION:** This equipment is designed to permit the connection of the earthed conductor of the DC supply circuit to the earthing conductor at the equipment.

If this connection is made, all of the following must be met:

- This equipment must be connected directly to the DC supply system earthing electrode conductor or to a bonding jumper from an earthing terminal bar or bus to which the DC supply system earthing electrode conductor is connected.
- This equipment must be located in the same immediate area (such as adjacent cabinets) as any other equipment that has a connection between the earthed conductor of the same DC supply circuit and the earthing conductor, and also the point of earthing of the DC system. The DC system must be earthed elsewhere.
- The DC supply source is to be located within the same premises as the equipment.
- Switching or disconnecting devices must not be in the earthed circuit conductor between the DC source and the point of connection of the earthing electrode conductor.

# HPE 1600 W Flex Slot Platinum Hot-plug Low Halogen Power Supply

Specification	Value
<b>Input requirements</b>	—
Rated input voltage	200 VAC to 240 VAC 240 VDC for China only
Rated input frequency	50 Hz to 60 Hz
Rated input current	8.7 A at 200 VAC 7.5 A at 230 VAC 7.2 A at 240 VDC
Maximum rated input power	1734 W at 200 VAC 1727 W at 230 VAC
BTUs per hour	5918 at 200 VAC 5891 at 230 VAC
<b>Power supply output</b>	—
Rated steady-state power	1600 W at 200 VAC to 240 VAC input 1600 W at 240 VDC input
Maximum peak power	2200 W for 1 ms (turbo mode) at 200 VAC to 240 VAC input

## Hot-plug power supply calculations

For hot-plug power supply specifications and calculators to determine electrical and heat loading for the server, see the Hewlett Packard Enterprise Power Advisor website (<https://www.hpe.com/info/poweradvisor/online>).

# Websites

## General websites

Single Point of Connectivity Knowledge (SPOCK) Storage compatibility matrix

<https://www.hpe.com/storage/spock>

Storage white papers and analyst reports

<https://www.hpe.com/storage/whitepapers>

For additional websites, see [Support and other resources](#).

## Support and other resources

### Subtopics

[Accessing Hewlett Packard Enterprise Support](#)

[Accessing updates](#)

[Remote support](#)

[Warranty information](#)

[Regulatory information](#)

[Documentation feedback](#)

## Accessing Hewlett Packard Enterprise Support

- For live assistance, go to the Contact Hewlett Packard Enterprise Worldwide website:

<https://www.hpe.com/info/assistance>

- To access documentation and support services, go to the Hewlett Packard Enterprise Support Center website:

<https://www.hpe.com/support/hpesc>

### Information to collect

- Technical support registration number (if applicable)
- Product name, model or version, and serial number
- Operating system name and version

- Firmware version
- Error messages
- Product-specific reports and logs
- Add-on products or components
- Third-party products or components

## Accessing updates

- Some software products provide a mechanism for accessing software updates through the product interface. Review your product documentation to identify the recommended software update method.
- To download product updates:

### Hewlett Packard Enterprise Support Center

<https://www.hpe.com/support/hpesc>

### My HPE Software Center

<https://www.hpe.com/software/hpesoftwarecenter>

- To subscribe to eNewsletters and alerts:

<https://www.hpe.com/support/e-updates>

- To view and update your entitlements, and to link your contracts and warranties with your profile, go to the Hewlett Packard Enterprise Support Center **More Information on Access to Support Materials** page:

<https://www.hpe.com/support/AccessToSupportMaterials>



#### **IMPORTANT:**

Access to some updates might require product entitlement when accessed through the Hewlett Packard Enterprise Support Center. You must have an HPE Account set up with relevant entitlements.

## Remote support

Remote support is available with supported devices as part of your warranty or contractual support agreement. It provides intelligent event diagnosis, and automatic, secure submission of hardware event notifications to Hewlett Packard Enterprise, which will initiate a fast and accurate resolution based on your product's service level. Hewlett Packard Enterprise strongly recommends that you register your device for remote support.

If your product includes additional remote support details, use search to locate that information.

### Remote support and Proactive Care information

#### HPE Get Connected

<https://www.hpe.com/services/getconnected>

#### HPE Proactive Care services

<https://www.hpe.com/services/proactivecare>

#### HPE Datacenter Care services

<https://www.hpe.com/services/datacentercare>

#### HPE Proactive Care service: Supported products list

<https://www.hpe.com/services/proactivecaresupportedproducts>

#### HPE Proactive Care advanced service: Supported products list

<https://www.hpe.com/services/proactivecareadvancedsupportedproducts>

### Proactive Care customer information

#### Proactive Care central

<https://www.hpe.com/services/proactivecarecentral>

#### Proactive Care service activation

<https://www.hpe.com/services/proactivecarecentralgetstarted>

## Warranty information

To view the warranty information for your product, see the [warranty check tool](#).

## Regulatory information

To view the regulatory information for your product, view the Safety and Compliance Information for Server, Storage, Power, Networking, and Rack Products, available at the Hewlett Packard Enterprise Support Center:

<https://www.hpe.com/support/Safety-Compliance-EnterpriseProducts>

### Additional regulatory information

Hewlett Packard Enterprise is committed to providing our customers with information about the chemical substances in our products as needed to comply with legal requirements such as REACH (Regulation EC No 1907/2006 of the European Parliament and the Council). A chemical information report for this product can be found at:

<https://www.hpe.com/info/reach>

For Hewlett Packard Enterprise product environmental and safety information and compliance data, including RoHS and REACH, see:

<https://www.hpe.com/info/ecodata>

For Hewlett Packard Enterprise environmental information, including company programs, product recycling, and energy efficiency, see:

<https://www.hpe.com/info/environment>

## Documentation feedback

Hewlett Packard Enterprise is committed to providing documentation that meets your needs. To help us improve the documentation, use the **Feedback** button and icons (at the bottom of an opened document) on the Hewlett Packard Enterprise Support Center portal (<https://www.hpe.com/support/hpesc>) to send any errors, suggestions, or comments. This process captures all document information.